

D  
C  
B  
A

D  
C  
B  
A

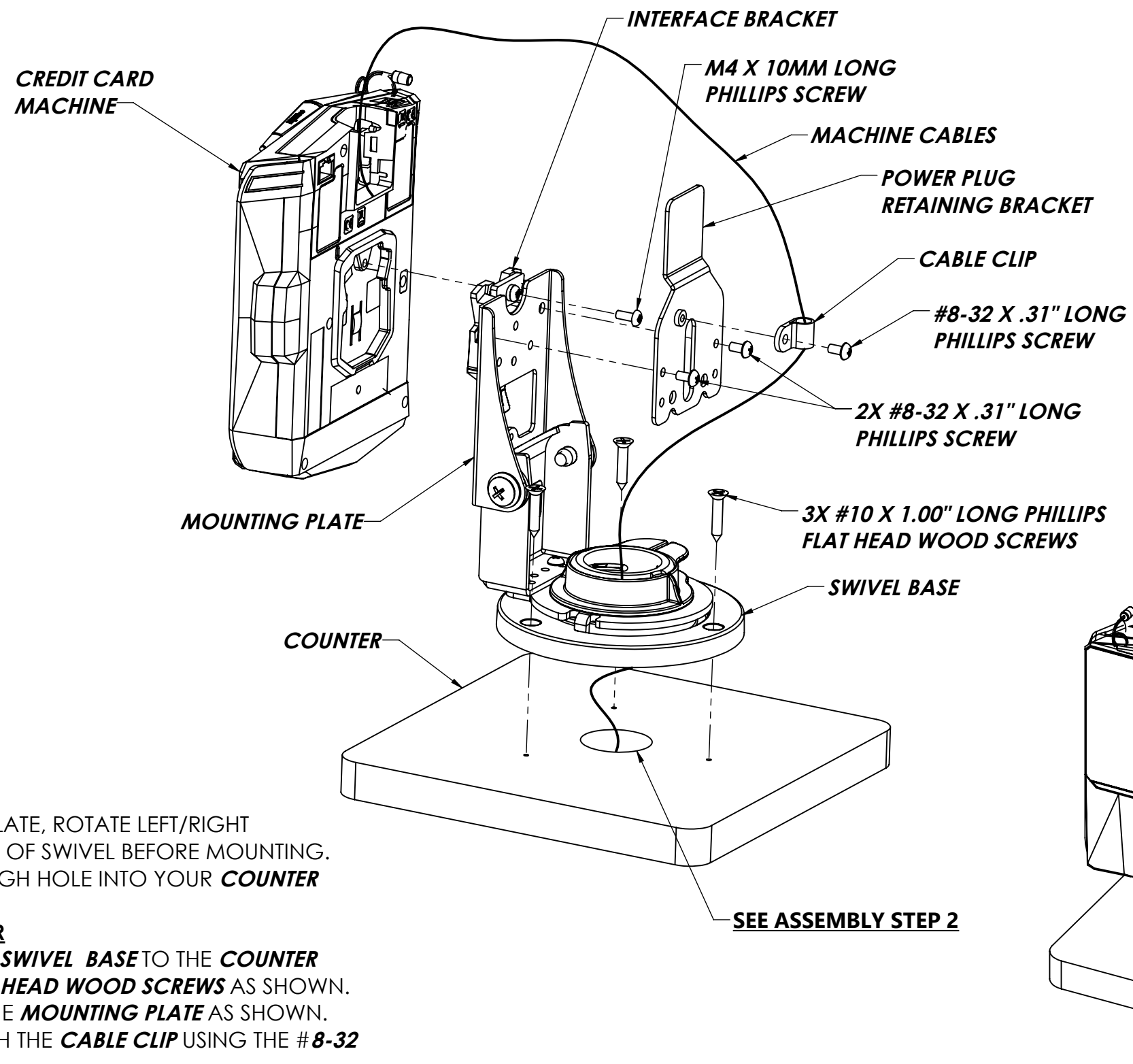

**TOOL LIST:**

1. #2 PHILLIPS SCREW OR DRILL DRIVER.
2. DRILL DRIVER & 3/32 DRILL BIT ( $\phi$ .094")
3. OPTIONAL 1 3/8" (1.375") SPADE BIT

**ASSEMBLY STEPS:**

1. USING THE **SWIVEL BASE STAND** AS A TEMPLATE, ROTATE LEFT/RIGHT TO STOP POINTS TO DETERMINE DIRECTION OF SWIVEL BEFORE MOUNTING.
2. (OPTIONAL) DRILL A 1 3/8" (1.375") THROUGH HOLE INTO YOUR **COUNTER** AS SHOWN.
3. MARK MOUNTING LOCATION ON **COUNTER**
4. DRILL **3X PILOT HOLES** AND ASSEMBLE THE **SWIVEL BASE** TO THE **COUNTER** USING **3X #10 X 1.00" LONG PHILLIPS FLAT HEAD WOOD SCREWS** AS SHOWN.
5. INSTALL THE **CREDIT CARD MACHINE** TO THE **MOUNTING PLATE** AS SHOWN.
6. ROUTE THE **MACHINE CABLES** AND ATTACH THE **CABLE CLIP** USING THE **#8-32 X .31" LONG PHILLIPS SCREW** AS SHOWN.
7. THREAD **M4 X 10MM LONG PHILLIPS SCREW** INTO **INTERFACE BRACKET** TO SECURE **CREDIT CARD MACHINE** TO STAND.
8. INSTALL THE **POWER PLUG RETAINING BRACKET** TO THE **MOUNTING PLATE** USING **2X #8-32 X .31" LONG PHILLIPS SCREW** AS SHOWN.

**SEE ASSEMBLY STEP 2**

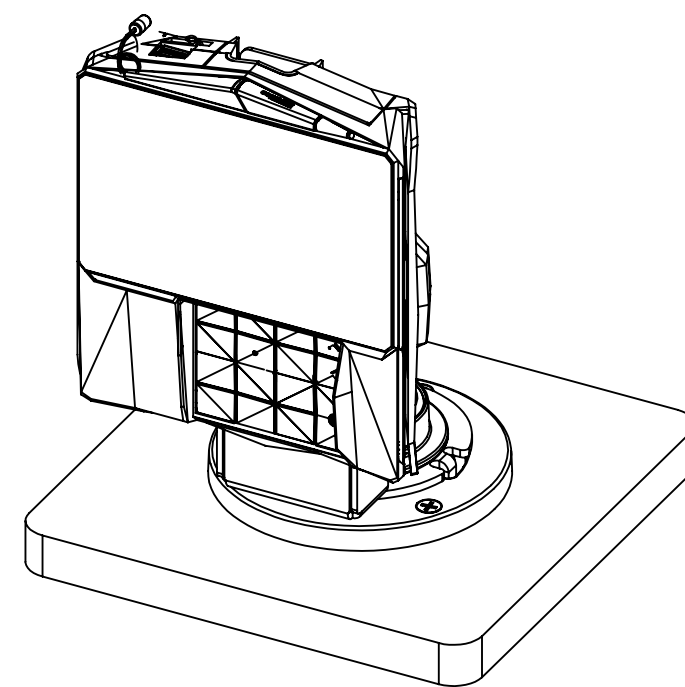

DWG. NO. 367-4977	REV. A
DRAWN J. BROWN	DATE 10/17/2018

TITLE LOW CONTOUR STAND 8-90 DEG CENTER HOLE ROUND BASE POWER PLUG RETAINING BRKT INGENICO LANE 3000, 7000
---

  
 SHEET 1 OF 1

REVISIONS				
REV	DESCRIPTION	DATE	BY	CHK'D
A		10/17/22	JEB	CDB

**CUSTOMER INSTRUCTIONS**