

PF8d & PF8t

Printer

User's
Guide



PF8d & PF8t

Printer

User's
Guide



Intermec Technologies Corporation

Worldwide Headquarters

6001 36th Ave.W.

Everett, WA 98203

U.S.A.

www.intermec.com

The information contained herein is provided solely for the purpose of allowing customers to operate and service Intermec-manufactured equipment and is not to be released, reproduced, or used for any other purpose without written permission of Intermec Technologies Corporation.

Information and specifications contained in this document are subject to change without prior noticed and do not represent a commitment on the part of Intermec Technologies Corporation.

© 2007-2009 by Intermec Technologies Corporation. All rights reserved.

The word Intermec, the Intermec logo, Norand, ArciTech, Beverage Routebook, CrossBar, dcBrowser, Duratherm, EasyADC, EasyCoder, EasySet, Fingerprint, i-gistics, INCA (under license), Intellitag, Intellitag Gen2, JANUS, LabelShop, MobileLAN, Picolink, Ready-to-Work, RoutePower, Sabre, ScanPlus, ShopScan, Smart Mobile Computing, SmartSystems, TE 2000, Trakker Antares, and Vista Powered are either trademarks or registered trademarks of Intermec Technologies Corporation.

There are U.S. and foreign patents as well as U.S. and foreign patents pending.

Wi-Fi is a registered certification mark of the Wi-Fi Alliance.

Microsoft, Windows, and the Windows logo are registered trademarks of Microsoft Corporation in the United States and/or other countries.

Bluetooth is a trademark of Bluetooth SIG, Inc., U.S.A.

Document Change Record

This page records changes to this document. The document was originally released as version 001.

Version	Date	Description of Change
004	3/2009	Corrected information regarding media specifications. Reformatted the manual to our new template.
003	06/2008	Corrected printing speeds for various printhead densities. Added procedure for adjusting Black Mark/Label Stop sensor. Minor format corrections.
002	08/2007	Removed listing of accessories. Revised information about installing and using a CompactFlash card. Minor format corrections.

Contents

Before You Begin.....	ix
Safety Information.....	ix
Global Services and Support.....	x
Warranty Information.....	x
Web Support.....	x
Telephone Support.....	x
Service Location Support.....	x
Who Should Read This Manual.....	xi
Patent Information.....	xi
Related Documents.....	xi

1 Using the PF8 Printers..... 1

Introducing the PF8 Printers.....	2
Features of the PF8 Printers.....	3
Front Controls and Indicators.....	3
Media Compartment.....	4
Other Features and Connections.....	5
Understanding the LED Indicators.....	6

2 Installing the Printer..... 7

Installing the Printer Driver.....	8
Connecting the Printer to Your Network.....	9
Connecting the Printer Through the USB Interface.....	9
Connecting the Printer Through the Serial Port.....	9
Connecting the Printer Through the Parallel Port.....	9
Turning On the Printer.....	9
Installing the CompactFlash Card (PF8t Only).....	10
Understanding Auto-Sensing Mode.....	11
Creating and Printing Labels.....	12
Loading Media.....	14
Loading Media for Tear-off Operation.....	15

Contents

Loading Media for Peel-Off Operation	18
Loading Media for Cut-Off Operation	19
Loading an Media from an External Supply	19
Loading Thermal Transfer Ribbon (PF8t Only)	20
3 Troubleshooting and Maintaining the Printer	23
Troubleshooting	24
Upgrading the Firmware	25
Cleaning the Case	26
Cleaning the Printhead	26
Adjusting the Thermal Printhead Pressure (PF8t only)	26
Adjusting the Printhead Alignment	27
Adjusting the Label Taken Sensor	28
Adjusting the Label Gap Sensor	29
Adjusting the Label Stop/Black Mark Sensor	29
A Specifications	31
PF8d Specifications	32
PF8t Specifications	35
Accessories	39
Cutter Kit	39
Stripper Module	39
B Media Specifications	43
Direct Thermal Media	44
Thermal Transfer Media	44
Transfer Ribbons	46

Contents

Labels.....47

Tags and Strip With Slots.....48

Tags and Strip With Black Marks.....49

Plain Continuous Stock.....50

Contents

Before You Begin

This section provides you with safety information, technical support information, and sources for additional product information.

Safety Information

Your safety is extremely important. Read and follow all warnings and cautions in this document before handling and operating Intermec equipment. You can be seriously injured, and equipment and data can be damaged if you do not follow the safety warnings and cautions.

This section explains how to identify and understand warnings, cautions, and notes that are in this document.



A warning alerts you of an operating procedure, practice, condition, or statement that must be strictly observed to avoid death or serious injury to the persons working on the equipment.



A caution alerts you to an operating procedure, practice, condition, or statement that must be strictly observed to prevent equipment damage or destruction, or corruption or loss of data.



Note: Notes either provide extra information about a topic or contain special instructions for handling a particular condition or set of circumstances.

Global Services and Support

Warranty Information

To understand the warranty for your Intermec product, visit the Intermec web site at www.intermec.com and click **Support > Returns and Repairs > Warranty**.

Disclaimer of warranties: The sample code included in this document is presented for reference only. The code does not necessarily represent complete, tested programs. The code is provided “as is with all faults.” All warranties are expressly disclaimed, including the implied warranties of merchantability and fitness for a particular purpose.

Web Support

Visit the Intermec web site at www.intermec.com to download our current manuals (in PDF). To order printed versions of the Intermec manuals, contact your local Intermec representative or distributor.

Visit the Intermec technical knowledge base (Knowledge Central) at www.intermec.com and click **Support > Knowledge Central** to review technical information or to request technical support for your Intermec product.

Telephone Support

In the U.S.A. and Canada, call **1-800-755-5505**.

Outside the U.S.A. and Canada, contact your local Intermec representative. To search for your local representative, from the Intermec web site, click **About Us > Contact Us**.

Service Location Support

For the most current listing of service locations, go to www.intermec.com and click **Support > Returns and Repairs > Repair Locations**.

For technical support in South Korea, use the after service locations listed below:

AWOO Systems

102-1304 SK Ventium
522 Dangjung-dong
Gunpo-si, Gyeonggi-do Korea, South 435-776
Contact: Mr. Sinbum Kang
Telephone: +82-31-436-1191
E-mail: mjyun@awoo.co.kr

IN Information System PTD LTD

6th Floor
Daegu Venture Center Bldg 95
Shinchun 3 Dong
Donggu, Daegu City, Korea
E-mail: jmyou@idif.co.kr or korlim@gw.idif.co.kr

Who Should Read This Manual

This user's guide is for the person who is responsible for installing, configuring, and maintaining the PF8d and PF8t printers.

This user's guide provides you with information about the features of the PF8d and PF8t printers, and how to install, configure, operate, maintain, and troubleshoot them.

Patent Information

This product is protected by one or more of the following United States patents:

5,581,293; 5,613,790; 5,927,876; 6,088,049; 6,345,920

There may be U.S. and Foreign Patents Pending.

Related Documents

Document Title	Part Number
<i>ESim for the PC4 and PF8 Printer Programmer's Reference Manual</i>	937-011-xxx

Before You Begin

The Intermec web site at www.intermec.com contains our documents (as PDF files) that you can download for free.

To download documents

- 1** Visit the Intermec web site at www.intermec.com.
- 2** Click **Support > Manuals**.
- 3** Use the **Product Category** field, the **Product Family** field, and the **Product** field to help you locate the product whose documentation you want to download.

Contents

1

Using the PF8 Printers

Use this chapter to familiarize yourself with the PF8 printers. In this chapter you will find these sections:

- **Introducing the PF8 Printers**
- **Features of the PF8 Printers**
- **Understanding the LED Indicators**

Introducing the PF8 Printers

The PF8 are lightweight, reliable, and easy-to-use printers. Both printers are designed to print a low volume of labels, less than 1000 labels, per day. There are two models of the PF8 printer:

- The PF8d is a 203 dpi direct thermal printer.
- The PF8t is a direct thermal or thermal transfer printer that is available in 203 and 300 dpi models.

Both PF8 printers are provided with parallel, serial RS-232, and USB ports. As an option, both models can be fitted with a cutter attachment or label stripper module. The PF8t can also be fitted with a CompactFlash card adapter.



The discharge of electrostatic energy accumulated on the human body, clothing, or other surfaces can damage or destroy the printhead or electronic components used in these printers. Avoid touching the electrical connectors while unpacking or setting up your printer.

Features of the PF8 Printers

This section describes the front controls and indicators, components of the media compartment, and connections located on the rear of the PF8d and PF8t printers.

Front Controls and Indicators

The PF8 printers are controlled by a **Power** switch, a **Feed** button, and a multi-color status LED.

The Power switch is located on the side of the PF8d and on the back of the PF8t.

You can use the **Feed** button in two ways:

- Tap it
A quick press-and-release causes the media to advance a short distance out of the printer.
- Hold it down
Holding the button down when the power is turned on causes the printer to enter Media Sensing mode. The printer configuration page prints when you release the button.

There are also cover open buttons located on each side of the printer which you press to access the media compartment.

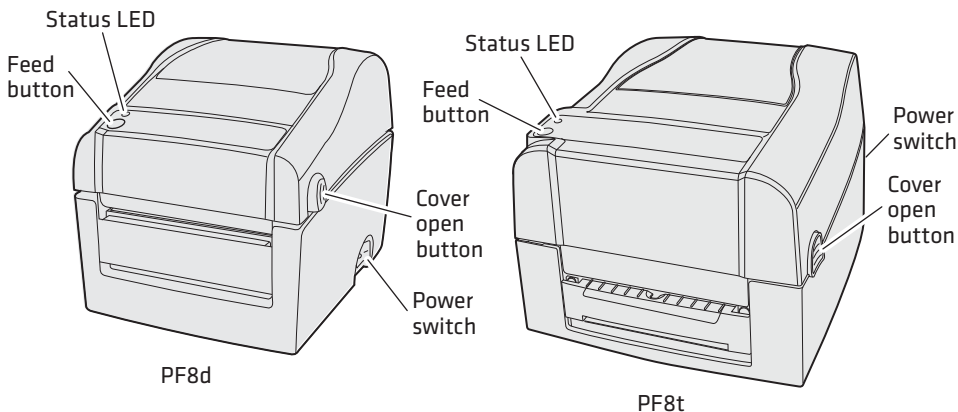

PF8d and PF8t Front Controls

Media Compartment

The PF8t is a thermal transfer or direct thermal capable printer. The media compartment accommodates the media supply and the transfer ribbon supply. In direct thermal printers like the PF8d, the top cover and the print mechanism are combined into a single unit.

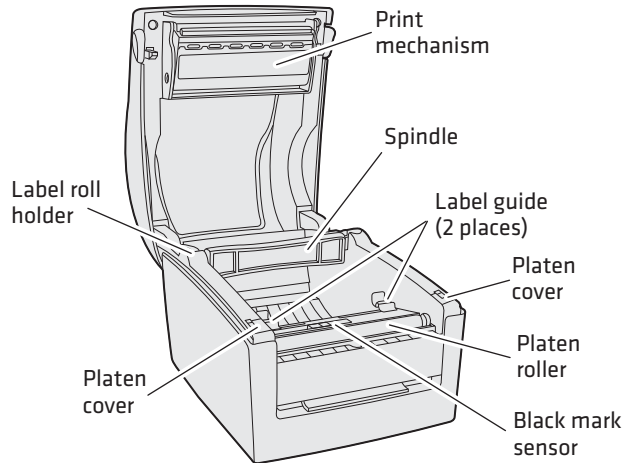

PF8d Media Compartment

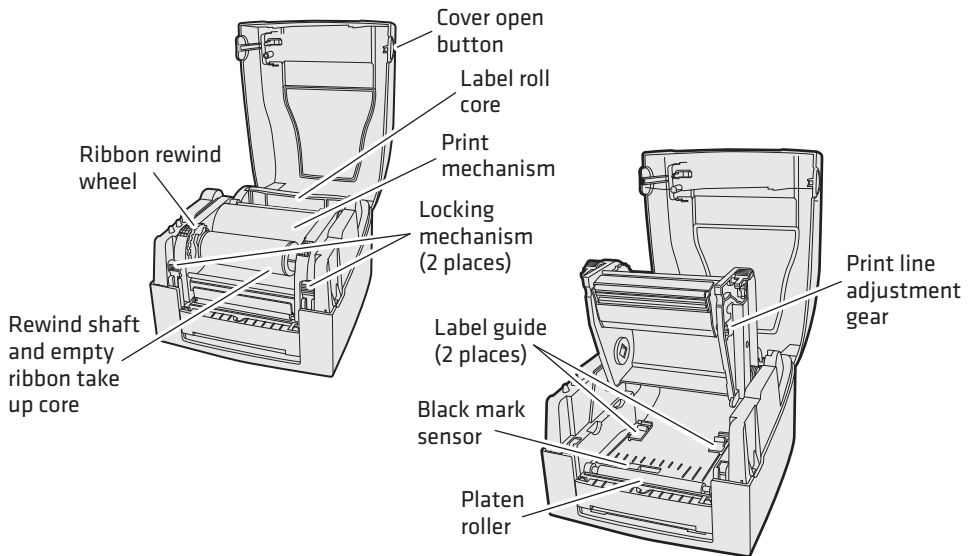

PF8t Media Compartment

Other Features and Connections

The rear and underside of the printers contain USB, serial, and parallel connections and additional features.

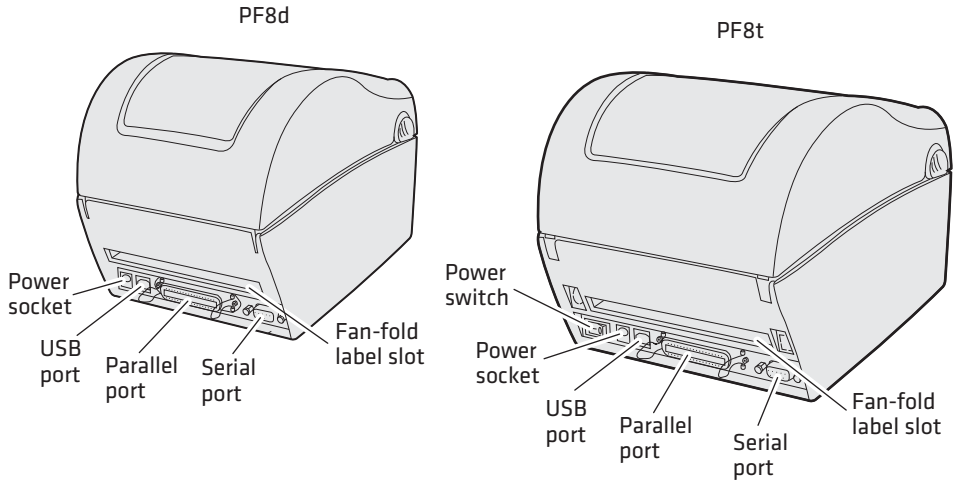

PF8d and PF8t Rear View Connections and Controls

The bottom of the PF8d also has hanger holes that allow you to wall-mount the printer.

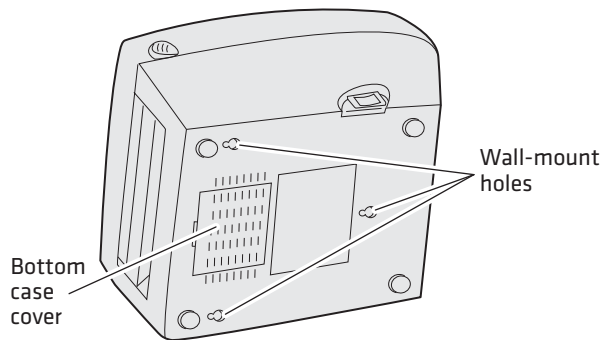

PF8d Wall-Mount Holes

Understanding the LED Indicators

When power to the printer is switched on, the status LED turns green, indicating that the printer is ready to accept print commands.

If the printer runs out of media or ribbon during printing, the LED turns red.

Other status indicators are shown in the table below. For more information on the various printer modes, see the *ESim for the PCA and PF8 Bar Code Label Printer Programmer's Reference Manual* (P/N 937-011-xxx).

LED Status Indicators

LED	Meaning
Green (blinking)	Auto-Sensing mode
Green (blinking)	Downloading font, form, or graphic
Green (solid)	Dump mode
Green (solid)	Ready mode
Green (solid)	Print mode
Orange (solid)	Boot mode
Red (blinking)	Media jam, overheated printhead or stepper motor
Red (blinking)	Downloading firmware
Red (solid)	Error mode

2

Installing the Printer

Use this chapter to install your PF8d and PF8t printers. In this chapter you will find these sections:

- **Installing the Printer Driver**
- **Connecting the Printer to Your Network**
- **Turning on the Printer**
- **Installing the CompactFlash card(PF8t Only)**
- **Understanding Auto-Sensing Mode**
- **Creating and Printing Labels**
- **Loading Media**
- **Loading Thermal Transfer Ribbon**

Installing the Printer Driver

You must install the Intermec InterDriver print driver in order to communicate with your PF8 printer. The InterDriver files are on the PrinterCompanion CD or available for download from the Intermec web site at <http://www.intermec.com>. Click **Support**, click **Downloads**, and then search for “interdriver”.

To install InterDriver

- 1 Load the PrinterCompanion CD into your desktop computer.
- 2 On the main screen, click **Software**. The InterDriver with ActiveX Controls introduction screen appears. For a copy of these instructions, click **Installation Instructions** at the bottom of the page.
- 3 Click **Install InterDriver**.
- 4 The File Download - Security Warning screen appears. Click **Run** to run the executable.
- 5 The Internet Explorer Security Warning screen appears. Click **Run** to start the InterDriver installation.
- 6 The Intermec End User License Agreement appears. Read the agreement and select the radio button to accept the agreement, and then click **Next**.
- 7 The Installation Directory screen appears. The default installation directory is c:\Intermec\InterDriver7. Click **Next** to use the default directory or specify a different location to install the files.
- 8 Clear the **Run Add Print Wizard after unpacking drivers** check box and click **Finish**.
- 9 On the New Hardware Wizard screen, select **Install from a list or specific location** and then click **Next** to continue.



Note: For LPT connections, you must restart your computer for Windows to detect the new hardware. For USB connections, the New Hardware Wizard will launch automatically when the printer is connected and turned on.

- 10 On the Search and Installation Options screen, click **Next**.

- 11 On the Hardware Installation warning screen, click **Continue Anyway**.
- 12 Click **Finish** to exit the New Hardware Wizard. InterDriver files are now installed on your computer.

Connecting the Printer to Your Network

All PF8 models are fitted with a 36-pin connector for the parallel interface port, a 9-pin connector for the RS-232 serial interface port, and a USB connector.

Connecting the Printer Through the USB Interface

To enable the USB connection, install the Intermec InterDriver software on your computer. The USB interface is not suitable for terminal connections or programming. See [“Installing the Printer Driver” on page 8](#).

Connecting the Printer Through the Serial Port

You can use the serial connection with either LabelShop or Intermec InterDriver. You can also use it to send commands directly through the terminal connection.

Connecting the Printer Through the Parallel Port

You can use the parallel connection with LabelShop or Intermec InterDriver. The parallel port supports Windows plug-and-play and additional status reporting.

Turning On the Printer



There is a danger of personal injury if the printer and power supply are operated in an environment where they can get wet. Use only Intermec power supply adapter P/N 1-092363-xx.

- 1 Place the printer on a stable surface.

- 2 Place the power supply adapter in a suitable location between the printer and an electrical outlet. The power supply adapter can be used for 100 to 240 VAC, 50 to 60 Hz.
- 3 Make sure the printer is off.
- 4 Insert the round connector on the power cord into the power receptacle in the back of the printer.
- 5 Insert the power cord plug into an AC socket.
- 6 Turn the printer on.
- 7 The status LED will change from red to green indicating that the power is turned on.

Installing the CompactFlash Card (PF8t Only)

The PF8t is supplied with 4 MB flash memory and 8 MB of SDRAM memory. The built-in memory can be expanded by using a CompactFlash card if more memory is required for your application. You will need to purchase and install a CompactFlash adapter to use a CompactFlash card.

You can select which memory source you want to use. Use Windows HyperTerminal to send an ESim **M** command to the printer to select your memory source. You can only use one memory source.

ESim memory allocation commands are:

- M0 Select built-in memory
- M1 Select CompactFlash memory
- MF Format the CompactFlash card

For more information on ESim commands, refer to the *ESim for the PC4 and PF8 Bar Code Label Printer Programmer's Reference Manual* (P/N 937-011-xxx).



Caution

Turn the printer power off when installing or removing the CompactFlash card.

To install the CompactFlash card

- 1 Turn the PF8t power off.

- 2** Open the top cover by pressing the cover open buttons on either side of the top cover.
- 3** Remove any media and the spindle.
- 4** Open and remove the CompactFlash card slot cover from the printer base.

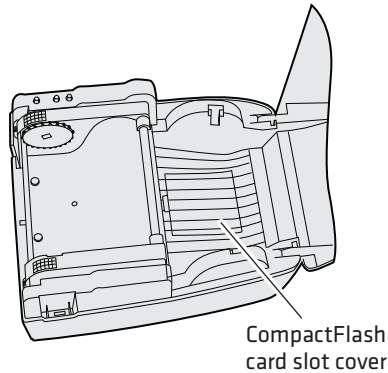

- 5** Insert the CompactFlash card in the CompactFlash adapter. Make sure that the card is oriented correctly to fit in the slot. Push firmly to seat the card.
- 6** Install the CompactFlash card slot cover.
- 7** Close the top cover and turn on the printer power.

Understanding Auto-Sensing Mode

The Auto-Sensing mode can be used for the following:

- Adjusting the label gap sensor
- Printing a test label with a test pattern and list of the printer's current settings
- Entering Dump mode

To use Auto-Sensing mode

- 1** Load media in the printer.
- 2** Press and hold the **Feed** button while turning the printer on. The status LED blinks green for 2 seconds, blinks red for 2 seconds, and then blinks green again.

- 3** If using continuous stock or gap media, release the **Feed** button when the LED is blinking green.
If using black marked media, release the **Feed** button when the LED is blinking red.
- 4** The printer automatically adjusts the label gap sensor and media feed according to the characteristics of the media. The printer may feed three to four labels before the adjustment is completed. If you are using peel-off media, remove the labels as they are fed out.
After a short delay, a test label will print and the printer will enter Dump mode. See the *ESim for the PC4 and PF8 Bar Code Label Printer Programmer's Reference Manual* (P/N 937-011-xxx) for additional information about Dump mode.
- 5** Press the **Feed** button once to return to normal operation, or press and hold the **Feed** button for at least 3 seconds after the test label prints to reset the printer to the default settings. The status LED turns red to indicate that the printer was reset to the default settings and then turns green.

Refer to the *ESim for the PC4 and PF8 Bar Code Label Printer Programmer's Reference Manual* (P/N 937-011-xxx) for an illustration and explanation of the test label.

Creating and Printing Labels

The PrinterCompanion CD contains software programs that you can use to configure the printer to create a wide variety of labels. These programs include:

- LabelShop (version 6.12 or later)
- InterDriver (version 7.06 or later)
- ESim Config Tool (version 2.1 or later)

Refer to the software documentation on the PrinterCompanion CD for detailed information about using these programs.

To download and install LabelShop (serial or parallel connection)

- 1** Use the Windows Control Panel Add/Remove Programs feature to uninstall all previous versions of LabelShop and service packs for LabelShop from the computer.

- 2** Connect the printer to the computer using a serial or parallel connection.
- 3** Download LabelShop from the www.intermec.com or insert the PrinterCompanion CD. If you download LabelShop, you will need to unzip the files.
- 4** Follow the installation prompts to install LabelShop in the default directory.
- 5** Download Service Pack 5 for LabelShop from the www.intermec.com and unzip the files.
- 6** Follow the installation prompts to install Service Pack 5 in the same directory where LabelShop is installed.

To download and install LabelShop (USB connection)

- 1** Use the Windows Control Panel Add/Remove Programs feature to uninstall all previous versions of LabelShop and service packs for LabelShop from the computer.
- 2** Connect the printer to the computer using a USB connection.
- 3** Install Windows InterDriver version 7.1.4 or later. These drivers are available on the PrinterCompanion CD or they can be downloaded from the www.intermec.com.
- 4** Download LabelShop from the www.intermec.com or insert the PrinterCompanion CD. If you download LabelShop, you will need to unzip the files.
- 5** Follow the installation prompts to install LabelShop in the default directory.
- 6** Download Service Pack 5 for LabelShop from the www.intermec.com and unzip the files.
- 7** Follow the installation prompts to install Service Pack 5 in the same directory where LabelShop is installed.

Loading Media

Both models of the PF8 printers can print on direct thermal media. The PF8t can also print on thermal transfer media such as self-adhesive labels, non-adhesive tags, or continuous stock. Printing on thermal transfer media also requires a thermal transfer ribbon.

There are three ways to handle media on the PF8 printers:

- Tear-off (straight-through) media is fed out the front of the printers and is torn off by pulling it upwards against the edge of the top cover.
- Cut-off media requires an optional paper cutter fitted on the front of the printer. The cutter is not designed to cut through adhesive; adhesive sticks to the cutting shears and prevents the cutter from operating.
- Peel-off (self-strip) media are self-adhesive labels that are automatically separated from the label backing after printing. Peel-Off media cannot be used with the cutter option.

Loading Media for Tear-off Operation

- 1 Press the cover open buttons on both sides of the case to open the top cover. Lift the cover upwards and rearwards.

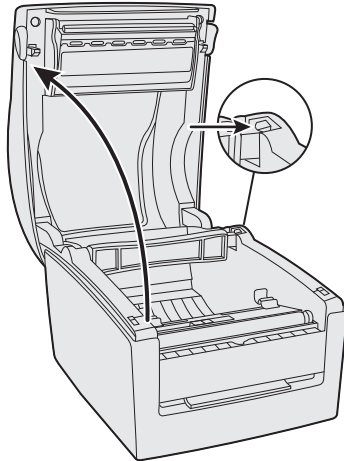

Note: On the PF8t you will also need to press the locking mechanism and open the print mechanism and ribbon container to load media and access the media adjustment tabs.

- 2** Pull or lift the spindle and remove the empty label roll core, if present. The PF8d spindle lifts up but remains attached to the printer while the PF8t spindle lifts completely out of the spindle compartment.

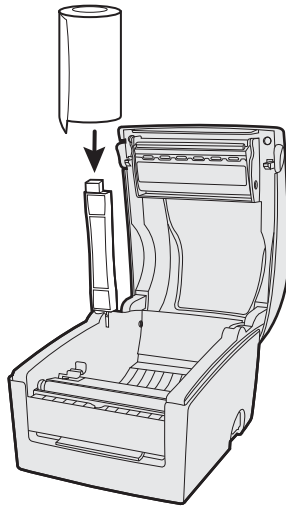

PF8d

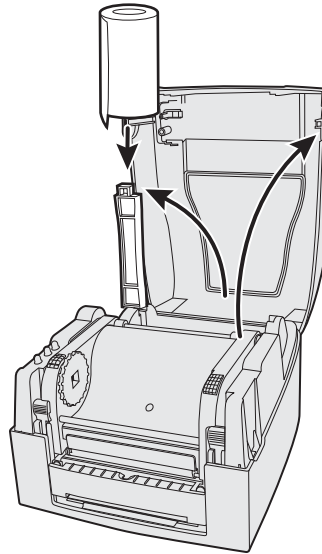

PF8t

- 3** Insert the spindle into the core of a fresh media roll. Rotate the spindle to fit the inside diameter of the core. See the core diameter markings on the spindle.

- 4** Put the label between the label guides and pull it forward.

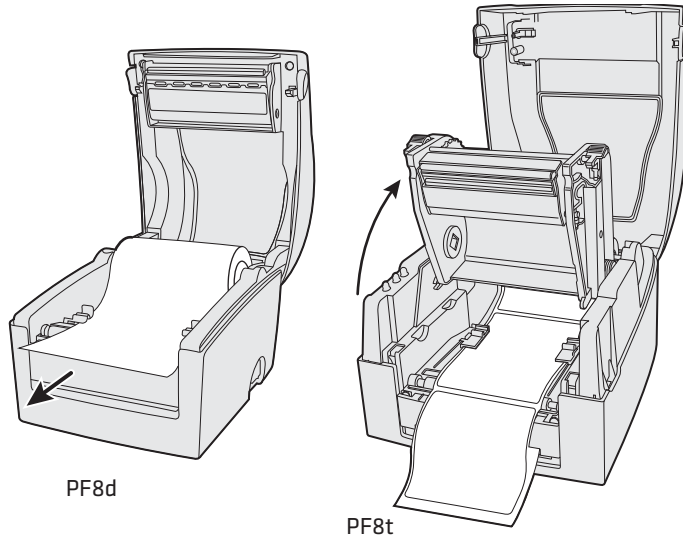

- 5** Adjust the label guide to fit the media you are using and close the top cover. On the PF8t you will first need to close the print mechanism and ribbon container before closing the cover.

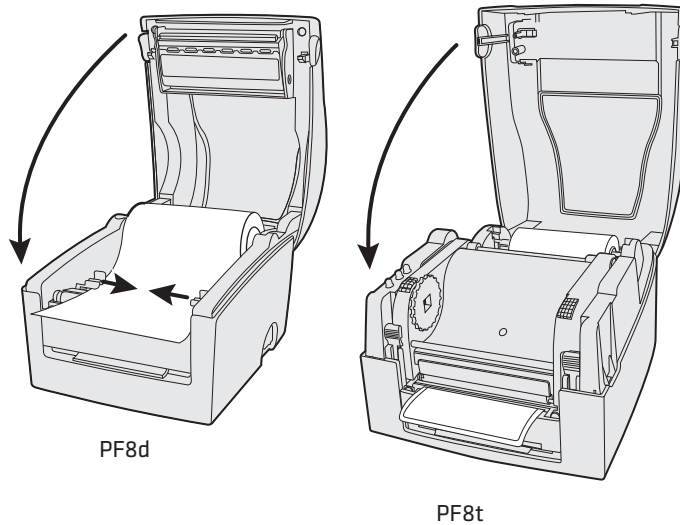



Note: If you are loading media for the first time or changing from another type or size of media, see **“Adjusting the Label Gap Sensor” on page 29.**

Loading Media for Peel-Off Operation

- 1 Press the cover open buttons on both sides of the case to open the top cover. Lift the cover upwards and rearwards.
- 2 Open the peel-off mechanism on the front of the printer.
- 3 Pull or lift the spindle and remove the empty label roll core, if present.



Note: The PF8d spindle lifts up, but remains attached to the printer while the PF8t spindle lifts completely out of the spindle compartment.

- 4 Insert the spindle into the core of a fresh media roll. Rotate the spindle to fit the inside diameter of the core (see the core diameter markings on the spindle).
- 5 Put the label between the label guides and pull it forward.
- 6 Peel away the label from the first 10 cm (4 in) of the liner.
- 7 Thread the liner around the peel-off bar and insert the liner inside the peel-off mechanism so that it protrudes from the slot below the mechanism.
- 8 Hold the labels and pull on the liner until it becomes tight.
- 9 Close the peel-off mechanism.
- 10 Close the top cover.



Note: If you are loading media for the first time or changing from another type or size of media, see **“Adjusting the Label Gap Sensor” on page 29.**

Loading Media for Cut-Off Operation



Caution

The cutter (optional accessory) cannot be used to cut through labels, only through the liner between the labels. Cutting through the labels will cause the adhesive to stick to cutting parts and prevent the cutter from working properly. Media rolls must be wound with the printable side facing upward to prevent jamming the cutter.

To load cut-off media

- 1 Press the release buttons on both sides of the case to open the top cover. Fold the cover upwards and rearwards.
- 2 Pull or lift the spindle and remove the empty label roll core (if present).



Note: The PF8d spindle lifts up, but remains attached to the printer while the PF8t spindle lifts completely out of the spindle compartment.

- 3 Insert the spindle into the core of a fresh media roll. Rotate the spindle to fit the inside diameter of the core (see the core diameter markings on the spindle).
- 4 Put the label between the label guides and pull the label forward.
- 5 Adjust the label guide to fit the media you are using.
- 6 Route the media through the slot in the optional cutter mechanism just in front of the tear bar.
- 7 Close the top cover.



Note: If you are loading media for the first time or changing from another type or size of media, see [“Adjusting the Label Gap Sensor” on page 29](#).

Loading an Media from an External Supply

Insert the media through the slot in the back of the printer. Follow the instructions for the type of media you are using. The spindle is not used when using an external media supply.



Note: Be careful to protect an external media supply from dirt, grit, dust, water, and direct sunlight.

Loading Thermal Transfer Ribbon (PF8t Only)

Thermal transfer ribbons are required when you print on thermal transfer (non-heat-sensitive) media. The type of transfer ribbon you use should match the face materials of the media to obtain the best durability and print quality.



Note: The PF8t can use only ribbons that are “wind direction out”, meaning the ribbon is loaded with the inked side (dull side) facing out. Using thermal transfer ribbons that are “wind direction in”, meaning the inked side is on the inside, cannot be loaded properly into the PF8t and may result in damage to the rewind motor.

To load a thermal transfer ribbon roll

- 1 Press the cover open buttons on both sides of the case to open the top cover. Fold the cover upwards and rearwards.
- 2 Press the green release tabs at the bottom of the top cover on both sides of the printhead.

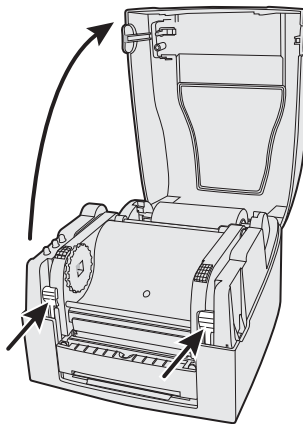

- 3** Lift the print carriage halfway up while keeping the top cover fully opened. Insert a new ribbon roll onto the ribbon supply shaft.

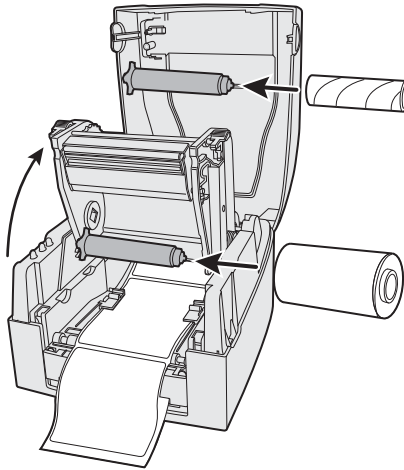

- 4** Feed the transfer ribbon from the ribbon supply shaft under the printhead.
- 5** Wrap the ribbon around the ribbon shaft. Using the tape fitted at the front of the ribbon leader, attach the leader to the top of the rewind core. Be careful to center align the ribbon leader with the core.

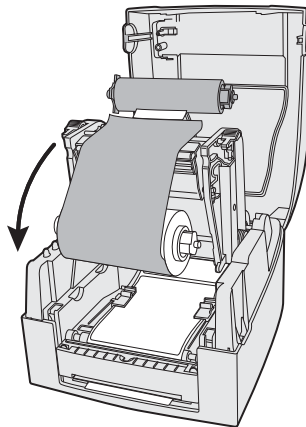

- 6** Close the print carriage by pressing firmly down on both sides. A loud click indicates the print carriage locked into place.

- 7** Firmly close the printer's top cover.

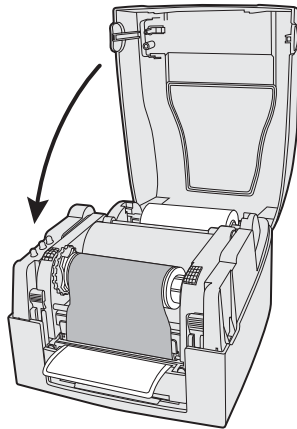

- 8** Tap the **Feed** button until the status LED turns green.

When you switch between direct thermal and thermal transfer printing, or when you switch between different types of transfer ribbon, you can remove a partially used transfer ribbon and save it for later use.

To remove a partially used ribbon

- 1** Press the cover open buttons on both sides of the case to open the top cover. Lift the cover upwards and rearwards.
- 2** Press the green release tabs at the bottom of the top cover on both sides of the printhead and lift the print carriage halfway up while keeping the top cover fully opened.
- 3** Using a pair of scissors, cut the transfer ribbon just below the rewind roll.
- 4** Rewind the unused ribbon onto the supply spool. Remove the roll by pushing it to the left until the right end disengages then lift the roll up. Fasten the loose end with a piece of tape or label to prevent the roll from unwrapping.
- 5** Remove the rewind roll by pushing it to the left until the right end disengages, then lift out. Dispose of the used ribbon.

Note: Keep the ribbon core. You will need it the next time you load ribbon.



3

Troubleshooting and Maintaining the Printer

Use this chapter to troubleshoot and maintain your PF8d and PF8t printers. This chapter contains these sections:

- **Troubleshooting**
- **Upgrading the Firmware**
- **Cleaning the Case**
- **Cleaning the Printhead**
- **Adjusting the Thermal Printhead Pressure**
- **Adjusting the Print Alignment**
- **Adjusting the Label Taken Sensor**
- **Adjusting the Label Gap Sensor**
- **Adjusting the Label Stop/Black Mark Sensor**

Troubleshooting

The following table lists possible printer issues that may arise and how to solve them.

Troubleshooting Printer Issues

Issue	Solution
LED unlit when power is on.	Make sure connections on the power supply are securely plugged into the AC receptacle on the printer and to an AC outlet.
LED is green but printer will not feed.	<ul style="list-style-type: none"> • Label taken sensor is on and the last label printed has not been removed. • Make sure correct type of interface cable is securely plugged in to both the printer and computer.
Printer seems to be working but nothing prints.	<p>Direct Thermal Printing</p> <ul style="list-style-type: none"> • Check that the heat-sensitive side of the media faces the printhead. If not, reload the media correctly. • Verify that the media is intended for direct thermal printing by testing to see if the media is blackened by heat from a hot object (70°C [160°F] or higher). <p>Thermal Transfer Printing</p> <ul style="list-style-type: none"> • Verify that the printer is loaded with thermal transfer ribbon and that the ink-coated side (dull side) of the ribbon is facing the media. If not, reload the ribbon correctly.
Print quality is poor.	Clean the printhead. See “Cleaning the Printhead” on page 26 . If cleaning the printhead does not improve print quality, adjust the printhead pressure. See “Adjusting the Thermal Printhead Pressure (PF8t only)” on page 26 .
Partial labels printed.	<ul style="list-style-type: none"> • Print carriage is not fully locked. Open the printer and lower the printhead completely. • Label caught on printhead. Remove label and clean printhead. See “Cleaning the Printhead” on page 26.
Printer continues to print or feed when it should stop printing.	<ul style="list-style-type: none"> • Stuck label is blocking the label gap sensor. Open the top cover, remove the label and clean the printhead. See “Cleaning the Printhead” on page 26. • Possible firmware problem. See “Upgrading the Firmware” on page 25.

Troubleshooting Printer Issues (continued)

Issue	Solution
Printing stops and status LED glows orange.	<ul style="list-style-type: none"> • Possible problem with label gap sensor. Perform an auto adjust in Auto-Sensing mode. • Possible media jam. Open the printer and check for stuck labels or ripped perforations. • Possible firmware problem. See “Upgrading the Firmware” on page 25.
Label stuck on roller.	Open the peel-off mechanism and peel off the stuck label while manually rotating the roller. Do not use any sharp tools to remove the label. Clean the peel-off mechanism and printhead. See “Cleaning the Printhead” on page 26.
Label taken sensor does not hold printing until the label or tag has been removed.	<ul style="list-style-type: none"> • Label or tag bent down due to excessive length and/or too thin or soft media. • Label or tag too short. • Label taken sensor or cable defective.
Indicator LED flashes red and printing is interrupted.	Overheated. Wait for the printer to cool down. When cool enough, the LED changes to green and printing (if halted) resumes.

Upgrading the Firmware

To upgrade the printer firmware you will need the following. Once you have downloaded the upgrade files, launch the ESim Config Tool and follow the instructions to upgrade the firmware.

- An upgrade file (.ufz). Download new firmware files from www.intermec.com.
- A host computer running Microsoft Windows with a USB, parallel, or serial RS-232 connection. Intermec recommends a parallel or USB connection.
- The Intermec ESim Config Tool for the PF8 is on the PrinterCompanion CD or can be downloaded from www.intermec.com. Use the ESim Config Tool to install a firmware upgrade file on the printer, download new fonts, and manage printer memory. It supports seven languages and comes with comprehensive online help.

Cleaning the Case

Keep your PF8 printer clean by periodically wiping it with a soft cloth dampened with water. Do not use abrasive cleaners or solvents that will scratch the surface of the case.

Cleaning the Printhead

When you are loading new media, use the Cleaning Card (P/N 1-110501-00) to clean the printhead before resuming printing. The Cleaning Card can also be used to remove label adhesive residue from the printhead.

To clean the printhead

- 1** Turn off power to the printer.
- 2** Open the top cover and print carriage.
- 3** Remove the media and, if present, also remove the transfer ribbon.
- 4** Insert the cleaning card under the print carriage where the media would normally go. Approximately 2 to 3 cm (1 in) of the card should extend to the front of the printhead.
- 5** Close the print carriage.
- 6** Use one hand to hold the printer steady. Use the other hand to pull the cleaning card forward until it is out of the printer.
- 7** Repeat Steps 4 through 6 to complete a second cleaning pass.
- 8** Dispose of the used cleaning card. Load printer with media and ribbon.

Adjusting the Thermal Printhead Pressure (PF8t only)

When you print with different label materials or use different types of ribbons on the PF8t printer, print quality may be affected due to differences in the material. If this happens, adjust the thermal printhead pressure appropriately for the type of material you are using.

To adjust thermal printhead pressure

- 1** Turn off power to the printer.
- 2** Press the cover open buttons on both sides of the case to open the top cover. Lift the cover upwards and rearwards.
- 3** Using a straight-slot screwdriver, turn the screws clockwise to increase printhead pressure or counterclockwise to decrease printhead pressure.

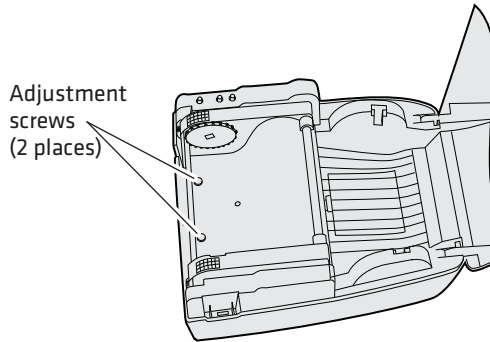

PF8t Printhead Adjustment Screws

Adjusting the Printhead Alignment

You can improve the print quality by adjusting the alignment between the printhead and the platen roller.

- Turn the adjustment screw counterclockwise or clockwise to adjust the contact between the printhead and platen roller.

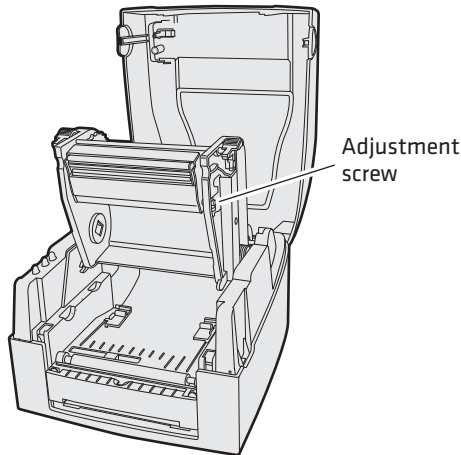

PF8t Printhead Alignment Adjustment Screw

Adjusting the Label Taken Sensor

The built-in label taken sensor can be enabled to pause printing until a printed label is removed from the printer's output slot. The printer will not continue printing until the label taken sensor no longer detects a label.

When you are using the ESim protocol, note the following:

- The label taken sensor must be enabled using the manual switch next to the sensor before it can be enabled or disabled using ESim commands.
- When switching between peel-off, tear-off, and cut-off operation, you must adjust the media feed in ESim by using a **j** command. For more information, see the *ESim for the PC4 and PF8 Printer Programmer's Reference Manual* (P/N 937-011-xxx).

If you are using InterDriver you can select one of the following modes of operation without issuing commands:

- Tear-off
- Peel-off with label taken sensor enabled

- Peel-off with label taken sensor disabled

The InterDriver files are on the PrinterCompanion CD or available for download from the Intermec web site at www.intermec.com.

Adjusting the Label Gap Sensor

The PF8 printers are fitted with a label gap sensor that detects the slots between tickets and tags or gaps between labels as media is fed past the sensor during printing. The label gap sensor determines the length or tag or labels and controls the media and ribbon feed accordingly.

The label gap sensor is a center-aligned photoelectric sensor that measures the light that passes through the media path. The transparency of the liner of a label supply may change from batch to batch, making it difficult for the sensor to determine the length of the media. If this happens, the status LED will change from green to orange, indicating you need to adjust the sensor using the Auto-Sensing mode. For more information, see “[Understanding Auto-Sensing Mode](#)” on page 11.

Adjusting the Label Stop/Black Mark Sensor



Note: This sensor is only adjustable on the PF8t.

The default position of the Label Stop Sensor/Black Mark sensor is all the way to the right of the slot, at the center of the printer. For an illustration, see the “[Media Compartment](#)” on page 4. For most media, this is the correct position. On rare occasions, such as unusually small labels or non-typical placement of black marks or notches, the sensor can be adjusted as necessary.

If you are using Gap sensing or Continuous stock, this sensor **MUST** be in the default, far-right position, or “Out of Paper”, “Media not Loaded”, or other media fault errors may continually occur.

To locate and adjust the black mark/label stop sensor

- 1 Open the top of the printer.

Chapter 3 – Troubleshooting and Maintaining the Printer

- 2** Lift the printhead.
- 3** The Black Mark sensor is right near the front of the printer, just behind the roller, in a groove that runs from the left side of the printer to the middle. The sensor optics are visible as a small slit on the left, and there is a ridged finger-notch to the right.
- 4** If the sensor is not all the way to the right, put your fingertip in the ridged finger-notch and slide the sensor all the way to the right. Do not touch the sensor itself, as natural finger oils may dirty the optics.
- 5** Lower the printhead, close the printer, and try printing again.

A

Specifications

This appendix provides technical specifications for the PF8d and PF8t printers and their available features and options.

PF8d Specifications

General Specifications

Resolution	8 dot/mm (203 dpi)
Print Mode	Direct Thermal
CPU	32 bit
Memory	4 MB flash, 8 MB SDRAM
Print Speed	2, 3, and 4 ips
Print Length	Maximum 1727 mm (68 in) Minimum 12.0 mm (0.47 in)
Print Width	Maximum 104 mm (4.09 in)
Sensor Type	Adjustable reflective sensor. Fixed transmissive sensor is center-aligned.
Sensor Detection	Label gap and black mark sensing, Label length autosensing and/or program command setting.
Media	Label roll outside diameter: Maximum 127 mm (5 in) Core diameter: 25 mm, 38 mm (1 in, 1.5 in) Width: 25 mm to 118 mm (1 in to 4.65 in) Thickness: 0.05 to 0.18 mm (.002 to .007 in)
Firmware	ESim (v7.x or later)
Software	ActiveX Controls (v1.3 or later) InterDriver (v7.06 or later) ESim Config Tool (v2.1 or later) LabelShop Patch (v6.12 or later))
Resident Fonts	6, 7, 10, 12, 24 points
Fonts Download	Windows bitmap font: Can be rotated in 8 orientations and expandable 8 times horizontally and vertically TrueType Font: v2.xx can be rotated in 4 orientations
Image Handling	BMP, PCX, Support ICO, WMF, JPG, EMF files through software.
Bar Codes	Code 39, Code 93, Code 128 (subset A, B, C), UCC/EAN-128, UPC A / E (add on 2 & 5), I 2 of 5, I 2 of 5 with check digit, I 2 of 5 with human readable check digit, EAN 8 / 13 (add on 2 & 5), Codabar, Post NET, MaxiCode, PDF417, Datamatrix code, QR code, UPC SCC, EAN?UCC composite code
Interfaces	Serial port: RS-232 (Baud rate: 1200 to 115200, XON/XOFF, RTS/CTS) USB port: v2.0 Parallel port: Compatible mode

General Specifications (continued)

Control Panel	One tri-color power LED, Feed function button.
Power	Input: ~ 100-240V 1,6A 50/60 Hz Output:  24V 2,5A
Environment	Operation: 5 °C to 40 °C (40 °F to 104 °F) Storage: -20 °C to 50 °C (-4 °F to 122 °F)
Certification	cULus, FCC Class A, CCC, CE, cUL, BSMI
Humidity	Operation: 30% to 85%, non-condensing. Free air Storage: 10% to 90%, non-condensing. Free air
Printer Dimensions	Length: 218 mm (8.58 in) Height: 166 mm (6.53 in) Width: 168 mm (6.61 in) Weight: 2.0 Kg (4.4 lbs)

Communication Interfaces

Serial Interface Connections

Pin	Host - DB9 Socket	Printer - DB9 Plug
1		+5V, max 500ma
2	RXD	TXD
3	TXD	RXD
4	DTR	N/C
5	GND	GND
6	DSR	RTS
7	RTS	CTS
8	CTS	RTS
9	RI	N/C

Serial default: 9600 baud, no parity, 8 data bits, 1 stop bit,
XON/XOFF protocol
Setting: RTS/CTS
RS-232 housing: 9-pin to 9-pin.



Note: The total current output from the serial port cannot exceed 500 mA.

USB Interface

Pin	Function
1	VBUS
2	D-
3	D+
4	GND

Connector Type: B

Parallel Interface

Pin	Function	Transmitter
1	/Strobe	host/printer
2-9	Data 0-7	host
10	/Acknowledge	printer
11	Busy	printer
12	/Paper empty	printer
13	/Select	printer
14	/Auto line feed	host/printer
15	N/C	
16	N/C	
17	N/C	
18	+5V, max 500ma	
19-30	Signal GND	host
31	/Initialize	host/printer
32	/Error	printer
33	Signal GND	
34-35	N/C	
36	/Select in	host/printer

Handshake: DSTB connects to the printer, BUSY connects to the host

Interface cable: Parallel cable compatible with computer.

Internal Interface

Pin	UART1 Wafer	Ethernet Module
1	N.C	N.C
2	TXD	RXD
3	RXD	TXD
4	CTS	RTS
5	GND	GND
6	RTS	CTS
7	E_MD	E_MD
8	RTS	CTS
9	E_RST	E_RST
10	+5V	+5V
11	GND	GND
12	+5V	+5V

PF8t Specifications

General Specifications

Resolution	8 dot/mm (203 dpi) or 12 dot/mm (300 dpi)
Print Mode	Direct Thermal/Thermal Transfer
CPU	32 bit
Memory	4 MB CompactFlash, 8 MB SDRAM
Print Speed	203 dpi: 2, 3, and 4 ips 300 dpi: 1 or 2 ips
Print Length	203 dpi: Maximum 1727 mm (68.0 in) Minimum 12 mm (0.47 in) 300 dpi: Maximum 900 mm (35.43 in) Minimum 12 mm (0.47 in)
Print Width	Maximum 104 mm (4.09 in)
Sensor Type	Adjustable reflective sensor. Fixed transmissive sensor, center-aligned.
Sensor Detection	Label gap and black mark sensing, label length autosensing or program command setting.
Media	Label roll outside diameter: Maximum 127 mm (5.00 in) Core diameter: 25 mm, 38 mm (1 in, 1.5 in) Width: 25 mm to 118 mm (1 in to 4.65 in) Thickness: 0.05 to 0.18 mm (.0025 to .0098 in)

Appendix A – Specifications

General Specifications (continued)

Firmware	ESim (v7.x or later)
Software	ActiveX Controls (v1.3 or later) InterDriver (v7.06 or later) ESim Config Tool (v2.1 or later) LabelShop Patch (v6.12 or later)
Resident Fonts	203 dpi: 6, 7, 10, 12, 24 points 300 dpi: 4, 6, 8, 10, 21 points
Fonts Download	Windows bitmap font: can be rotated in 8 orientations and expandable 8 times horizontally and vertically TrueType Font: v2.xx can be rotated in 4 orientations
Image Handling	BMP, PCX, Support ICO, WMF, JPG, EMF files through software.
Bar Codes	Code 39, Code 93, Code 128 (subset A, B, C), UCC/EAN-128, UPC A / E (add on 2 & 5), I 2 of 5, I 2 of 5 with check digit, I 2 of 5 with human readable check digit, EAN 8 / 13 (add on 2 & 5), Codabar, Post NET, MaxiCode, PDF417, Datamatrix code, QR code, UPC SCC, EAN?UCC composite code
Interfaces	Serial port: RS-232 (Baud rate: 4800 to 115200, XON/XOFF, RTS/CTS) USB port: v2.0 Parallel port: Compatible mode
Control Panel	One tri-color power LED, Feed function button
Power	Input: ~ 100-240V 1,6A 50/60 Hz Output:  24V 2,5A
Environment	Operation: 5°C to 40°C (40°F to 104°F) Storage: -20°C to 50°C (-4°F to 122°F)
Certification	cULus, FCC Class A, CCC, CE, cUL, BSMI
Humidity	Operation: 30% to 85%, non-condensing. Free air Storage: 10% to 90%, non-condensing. Free air
Printer Dimensions	Length: 285 mm (11.2 in) Height: 172 mm (6.8 in) Width: 226 mm (8.9 in) Weight: 2.5 Kg (5.5 lbs)

Communication Interfaces

Serial Interface Connections

Pin	Host - DB9 Socket	Printer - DB9 Plug
1		+5V, max 500ma
2	RXD	TXD
3	TXD	RXD
4	DTR	N/C
5	GND	GND
6	DSR	RTS
7	RTS	CTS
8	CTS	RTS
9	RI	N/C

Serial default: 9600 baud, no parity, 8 data bits, 1 stop bit, XON/XOFF protocol

Setting: RTS/CTS

RS-232 housing: 9-pin to 9-pin



Note: The total current output from the serial port cannot exceed 500 mA.

USB Interface

Pin	Function
1	VBUS
2	D-
3	D+
4	GND

Connector Type: B

Parallel Interface

Pin	Function	Transmitter
1	/Strobe	host/printer

Parallel Interface (continued)

Pin	Function	Transmitter
2-9	Data 0-7	host
10	/Acknowledge	printer
11	Busy	printer
12	/Paper empty	printer
13	/Select	printer
14	/Auto line feed	host/printer
15	N/C	
16	N/C	
17	N/C	
18	+5V, max 500ma	
19-30	Signal GND	host
31	/Initialize	host/printer
32	/Error	printer
33	Signal GND	
34-35	N/C	
36	/Select in	host/printer

Handshake: DSTB connects to the printer, BUSY connects to the host.

Interface cable: Parallel cable compatible with computer.

Internal Interface UART1

Pin	UART1 Wafer	Ethernet Module
1	N.C	N.C
2	TXD	RXD
3	RXD	TXD
4	CTS	RTS
5	GND	GND
6	RTS	CTS
7	E_MD	E_MD
8	RTS	CTS

Internal Interface (continued)UART1

Pin	UART1 Wafer	Ethernet Module
9	E_RST	E_RST
10	+5V	+5V
11	GND	GND
12	+5V	+5V

Internal Interface UART2

Pin	UART2 Wafer	Expansion Module
1	+5V	+5V
2	CTS	RTS
3	TXD	RXD
4	RTS	CTS
5	RXD	TXD
6	GND	GND

Accessories

Accessories for the PF8 printers are sold and ordered separately. Serial and parallel cables, media, and transfer ribbons are also available. To order, contact your local Intermec sales representative.



Warning

The Cutter Kit and Stripper Module must only be installed by an authorized service technician. Intermec assumes no responsibility for personal injury or damage if the installation is performed by an unauthorized person.

Cutter Kit

The cutter is designed to cut continuous paper-based stock or liner between labels.

Stripper Module

The self-strip feature peels the label away from the liner (backing paper) as it prints for faster on-demand labeling.

Appendix A – Specifications

B

Media Specifications

PF8d/PF8t Printer User's Guide This appendix explains the different types of media that the PF8 printers can use and indicates the allowed dimensions of that media.

Direct Thermal Media

Intermec offers a premium and an economy grade of direct thermal media for the PF8 printers.

Premium Quality

Top-coated media with high demands on printout quality and resistance against moisture, plasticizers and vegetable oils.

Examples of Premium Quality Media

Europe	North America
Thermal Top Board	Duratherm Ltg.
Thermal Top	Duratherm IR
Thermal Top High Speed	

Economy Quality

Uncoated media with less resistance to moisture, plasticizers and vegetable oils. In all other respects, it is equal to premium quality.

Examples of Economy Quality Media

Europe	North America
Thermal Eco	Duratherm II
Thermal Eco Board	Duratherm II Tag

Thermal Transfer Media

Intermec offers stock media for thermal transfer printing in a wide range of quality grades.

Uncoated Papers

Used for economical high-volume printing in combinations with GP/TMX1500 ribbons.

Examples of Uncoated Papers

Europe	North America
TTR Uncoated	Not Available

Coated Papers

Coated papers have various coat-weight, smoothness, and gloss. To be used with HP/TMX2200 and GP/TMX1500 ribbons.

Examples of Coated Papers

Europe	North America
TTR Matte	Duratran II
TTR Premium	Duratran II Tag
TTR Premium Board	

Polyethylene Plastics

Good resistance to water and many common chemicals. Can be used outdoors and offers good tear resistance. Most often used in combination with HP/TMX2200 ribbons.

Examples of Polyethylene Plastics

Europe	North America
TTR Polyethylene	Duratran II Kimdura
TTR Gloss Polyethylene	Duratran II Synthetic Tag
	Duratran II Syntran

Polyesters

The materials of choice in combination with HR/TMX3201/TMX3202 ribbons. Gives high resistance to chemicals, heat, and mechanical abrasion.

Examples of Polyesters

Europe	North America
TTR High Gloss Polyester	Duratran II Gloss Polyester

Transfer Ribbons

Intermec offer three types of thermal transfer ribbons optimized for different purposes:

General Purpose (GP/TMX1500)

General purpose transfer ribbons allow high speed printing and give a good printout, but are somewhat sensitive to smearing. These are best suited choice for uncoated and coated papers.

High Performance (HP/TMX2200)

High performance transfer ribbons allow high speed printing and gives a highly readable and defined printout on most face materials with smooth surfaces. They have good “smear resistance” and are most suitable for intricate logotypes and images on matte coated papers and synthetic face materials.

High Resistance (HR/TMX3201/TMX3202)

High resistance transfer ribbons give an extremely durable printout that is resistant to most chemical agents and high temperatures. However, such transfer ribbons set high demands on the receiving face material, which must be very smooth, such as polyesters.



Note: Intermec thermal transfer ribbons are engineered specifically for the PF8 printheads.

Labels

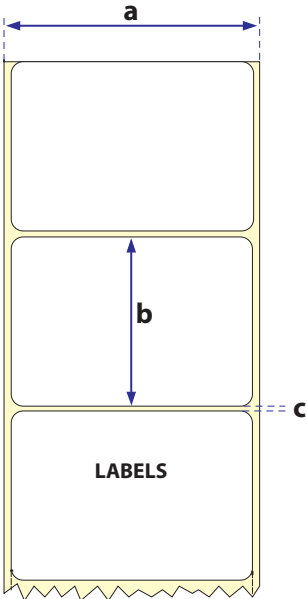

Media width includes liner (a)

Maximum: 116.0 mm (4.57 in)

Minimum: 25.0 mm (1 in)

Label length (b)

Minimum: 12.0 mm (0.5 in)

Label gap height (c)

Maximum: 10 mm (0.39 in)

Minimum: 3 mm (0.12 in)

Liner

Opacity: 75%

Tags and Strip With Slots

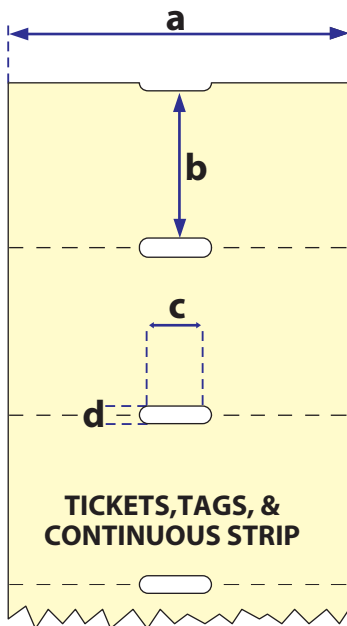

Tag or strip width (a)

Maximum: 116.0 mm (4.57 in)

Minimum: 25.0 mm (1.00 in)

Tag length (b)

Minimum: 12.7 mm (0.50 in)

Detection slot width (c)

Minimum: 14.0 mm (0.55 in)

Detection slot height (d)

Maximum: 10.0 mm (0.39 in)

Minimum: 3.0 mm (0.12 in)

The label gap sensor is offset 2.5 mm (0.10 in) to the left of the center of the media path.

Tags and Strip With Black Marks

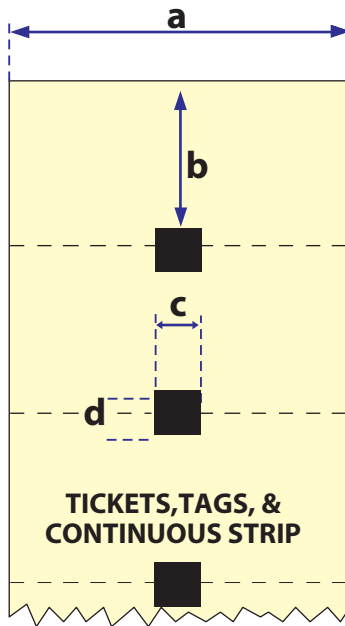

Tag or strip width (a)

Maximum: 116.0 mm (4.57 in)

Minimum: 25.0 mm (1.00 in)

Tag length (b)

Minimum: 12.7 mm (0.50 in)

Detection slot/Black mark width (c)

Minimum: 14.0 mm (0.55 in)

Black mark height (d)

Maximum: 10.0 mm (0.39 in)

Minimum: 3.0 mm (0.12 in)

The black mark sensor is centered on the media path.

Maximum reflectance 5% at 940 nanometers. Carbon black.

Plain Continuous Stock

The PF8 printers can use continuous stock without any detection slots or black marks. The printer must be set for continuous stock by using the ESim **Q** command. For more information, see the *ESim for the PC4 and PF8 Printer Programmer's Reference Manual* (P/N 937-011-xxx).

The length of each copy is decided by the size of the print image and any additional media feed is decided by the **Q** command. Continuous stock cannot be used in the Auto-Sensing mode.

Tag or strip width (a)

Maximum: 116.0 mm (4.57 in)

Minimum: 25.0 mm (1.00 in)



Worldwide Headquarters
6001 36th Avenue West
Everett, Washington 98203
U.S.A.

tel 425.348.2600

fax 425.355.9551

www.intermec.com

© 2009 Intermec Technologies
Corporation. All rights reserved.

PF8d/PF8t Printer User's Guide



P/N 934-011-004