

5

PRINT MODE & INDEX METHOD

- Thermal transfer printers can operate in direct thermal or thermal transfer mode and must be set to the correct print mode for proper results.
- All Advantage printers can use black bar, gap or notch indexing.
- Your label printing software should provide the means to set these parameters. See your software documentation for details.
- Refer to the *Cognitive Programmer's Guide* included on the CD ROM to set these parameters using the Cognitive Programming Language.
- The CD ROM includes Windows drivers, label design software and additional information.

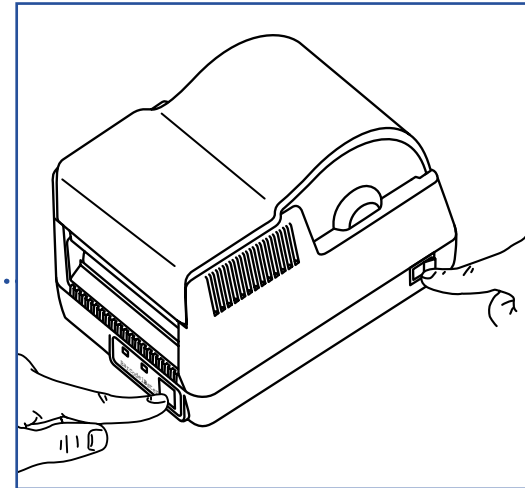

T

SELF TEST

The self test checks the printer's overall operability.

IMPORTANT! The printer should be loaded with media, connected to AC power and turned off.

- Press and hold the FEED button.
- Turn the printer ON while holding the FEED button. Release the FEED button when self test starts to print.
- Turn the printer off and on again to return to normal printing operation.

IMPORTANT! After performing a self test, the printer is in hexadecimal dump mode and cannot print normally until you cycle the power.

M

MAINTENANCE (With Every Media Roll)

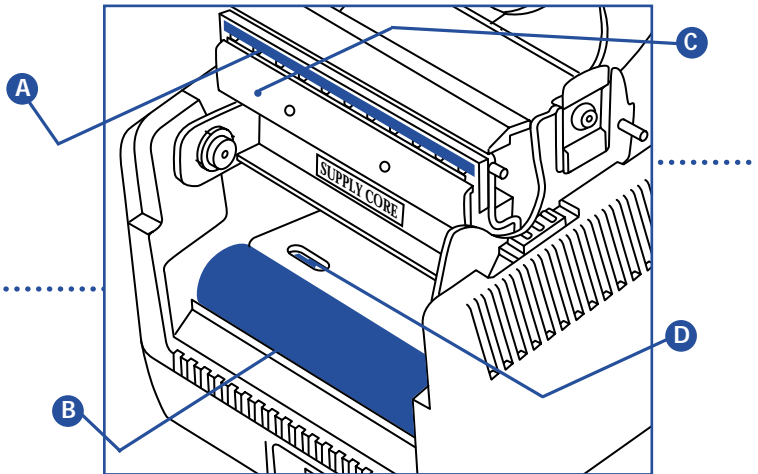

Clean the print head **A**, drive roller **B** and the index sensors **C** and **D** with a soft, lint free cloth lightly saturated with 99% isopropyl alcohol. Press the FEED button to clean all sides of the roller.

CAUTION! Incorrectly cleaning the printer will cause permanent damage and void the printer's warranty. Cognitive recommends using a certified cleaning pen for all your printer's cleaning requirements, P/N 60-14-00-0002.

I

MORE INFO

Refer to your CD-ROM for more detailed information. Refer to the Cognitive web site for the latest firmware and software upgrades, including printer drivers.

Contact Cognitive for all your supply needs, including media and cleaning pens.

General Mailing Address:
691 Corporate Circle, Golden, CO 80401
Tel: 303.273.1400 Toll Free: 800.525.2785
Fax: 303.273.1414
Website: www.cognitive.com
E-mail: info@cognitive.com

USA Sales
Toll Free: 800.525.2785 Fax: 303.273.1414
E-mail: sales@cognitive.com

Technical Support
Toll Free: 888.715.7190
E-mail: techsup@cognitive.com

Europe
Atlantic Street
Altrincham, Cheshire, WA14 5QJ
United Kingdom
Tel: +44.161.929.9933 Fax: +44.161.927.7664
E-mail: info@uk-axiohm.com

Asia-Pacific
PO Box 677
Level 3, 39 Leighton Place
Hornsby NSW 2077 Australia
Tel: +61.2.9477.1999 Fax: +61.2.9477.1453
E-mail: sales@dhetechnology.com.au

Japan
2-23-2 Higashi-Ikebukuro
Toshima-KU
Tokyo 170 Japan
Tel: +81.135.391.7689 Fax: +81.135.391.7692
E-mail: japansales@cognitive.com

All Blaster ADVANTAGE printer models are manufactured in an ISO 9002 compliant environment.

WARNING - SHOCK HAZARD and STATIC DISCHARGE:

 Never operate the printer in a location where it can get wet. Personal injury could result. The discharge of electrostatic energy that accumulates on the surface of the human body or other surfaces can damage or destroy the print head or electronic components used in this device. DO NOT TOUCH the print head or the electronic components under the print head carriage.

CAUTION - PRINTER SETUP & HANDLING:

 When installing or modifying the printer setup or configuration, ALWAYS TURN POWER OFF before: (1) connecting any cables, (2) performing any cleaning or maintenance operations, (3) moving the printer.

EUROPEAN COMPLIANCE:

 This is a Class A product. In a domestic environment this product may cause radio interference in which case the user may be required to take adequate measures.

FCC DECLARATION OF CONFORMITY:

 This equipment has been tested and found to comply with the limits for a Class A digital device, pursuant to Part 15 of the FCC Rules. These limits are designed to provide reasonable protection against harmful interference when the equipment is operated in a commercial environment. This equipment generates, uses, and can radiate radio frequency energy and, if not installed and used in accordance with the instruction manual, may cause harmful interference to radio communications. Operation of this equipment in a residential area is likely to cause harmful interference in which case the user will be required to correct the interference at his own expense.

INDUSTRY CANADA NOTICE:

This class B digital apparatus complies with Canadian ICS-003 requirements. Cet appareil numérique de la classe B est conforme a la norme NMB-003 du Canada.

Copyright © 2001 Cognitive. Cognitive™ and Blaster ADVANTAGE™ are trademarks of Cognitive. Other products and corporate names used in this publication may be trademarks or registered trademarks of other companies and are used only for explanation and to their owner's benefit, without intent to infringe. No part of this manual may be reproduced for any purpose or in any form, including electronic storage and retrieval, without the express permission of Cognitive.

102-101-01 Rev. A April 2001

Blaster ADVANTAGE

QUICK START

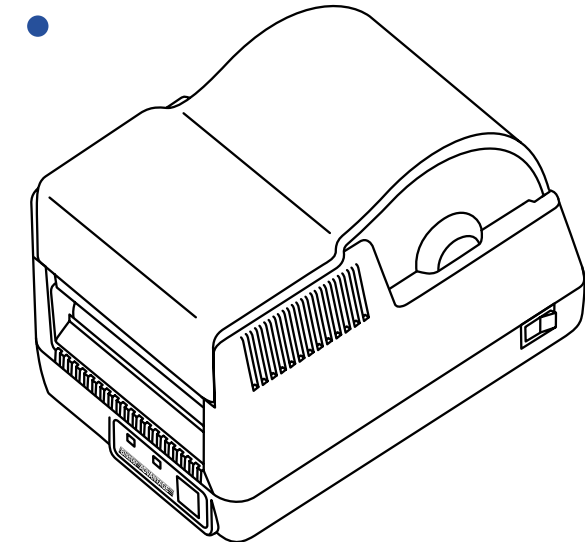

All BD and BT models

Cognitive

1 POWER & CABLES

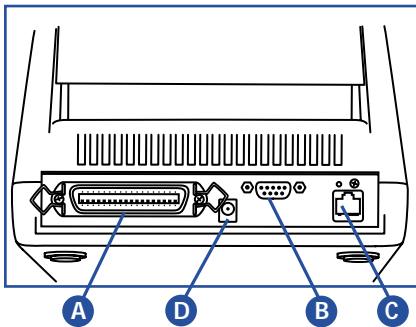

Connect a parallel cable **A**, serial cable **B** or ethernet cable **C** to the back of the printer. Connect the power cable **D** to the back of the printer and plug it in.

IMPORTANT! Use only the 19VAC power supply provided with the printer.

Note: This guide shows a BT4 Ethernet printer. Your printer may look different, but the operations are the same.

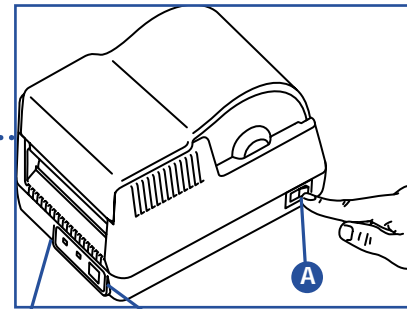

Turn the printer on **A**.

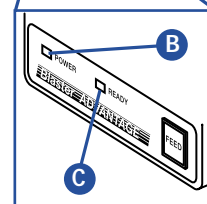

The Power light **A** is green when ready to print.

The Ready light **C** is green when ready to receive data.

Note: If the Ready light is red, check for printer error, empty media roll, or paused operation during batch mode processing.

2 OPEN PRINTHEAD

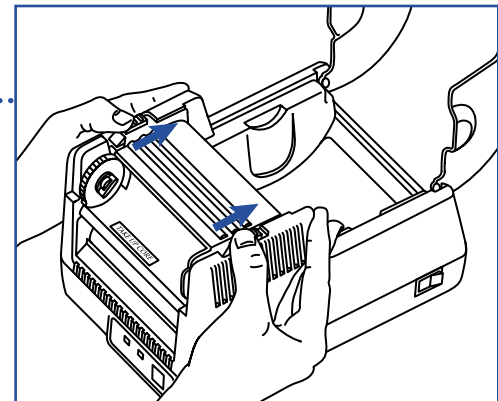

Open the dust cover. Slide back the black latches to release the print mechanism. Raise the mechanism to prepare to load print media or ribbon and to clean the printer.

3 LOAD RIBBON (Thermal Transfer Only)

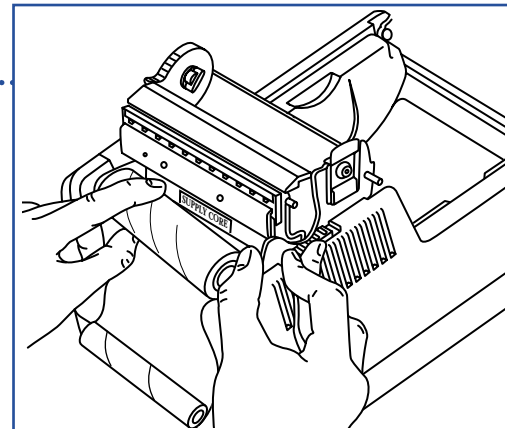

Unwind a few inches of the new ribbon from the supply core. Pull gently on the supply core mount flexible arm and insert the ribbon supply roll.

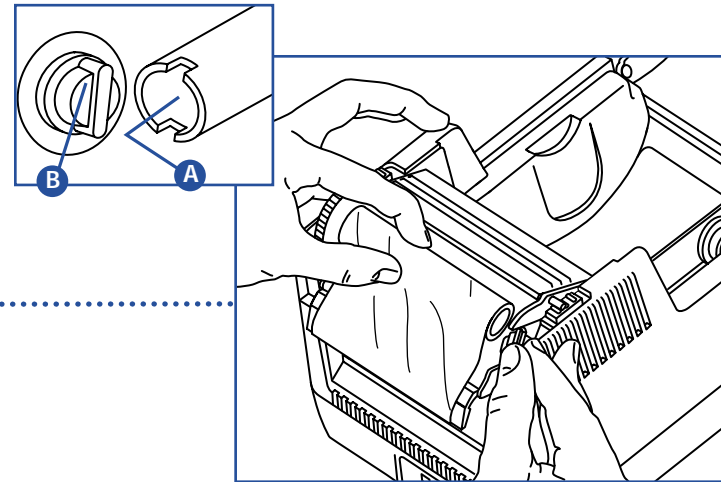

Turn the ribbon takeup core **A** (see inset) to align the slotted end with the takeup mount **C**. Gently pull the flexible arm out and snap the takeup core into place.

Note: The printer automatically takes up the slack in the ribbon.

4 LOAD MEDIA

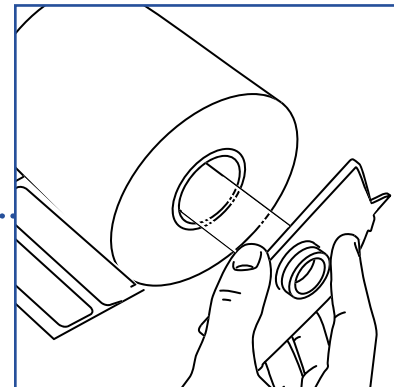

Lift out the media spindle. Load the media onto the spindle, keeping the black media guide to the right of the media roll.

IMPORTANT! The imaging surface must face up as it passes under the print mechanism.

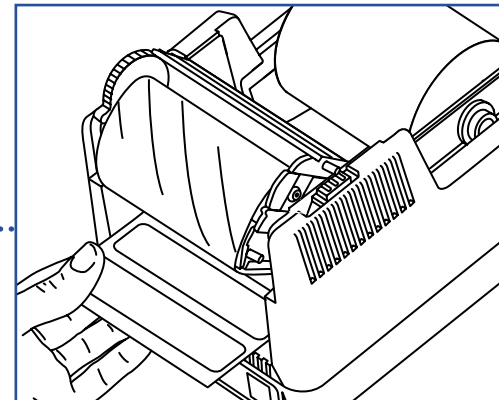

Place the loaded media spindle in the printer with the black guide to the right. Feed the media under the open print mechanism.

Note: The media spindle should fit securely with the black guide pressed securely against the media roll.

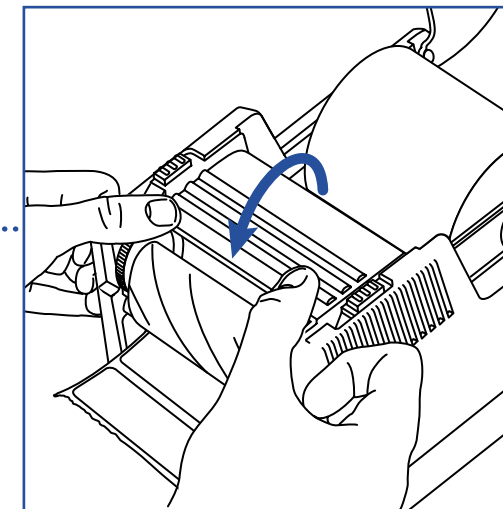

Lower the print mechanism and press down firmly to secure latches.

Note: The latches click when properly closed. With the media and ribbon loaded, the Ready light turns green.