

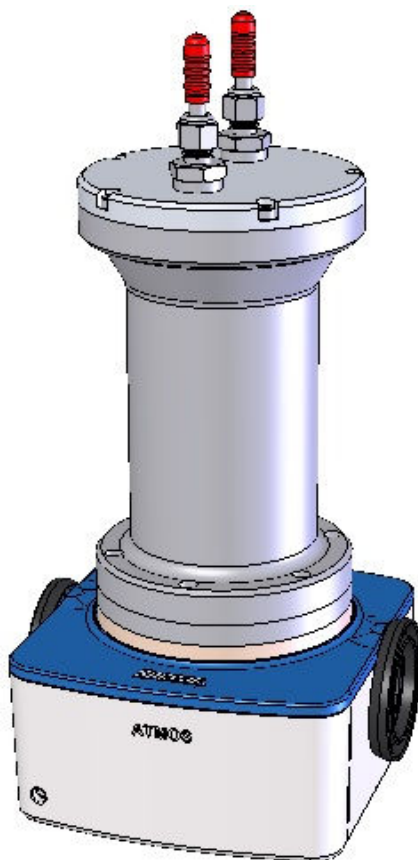

Atmos Series  
Heatable Long Pathlength Gas Cells  

---

*User Manual*





Atmos Series  
Heatable Long Pathlength Gas Cells

---

*User Manual*

# *Atmos Heatable Long Pathlength Gas Cells*

## *P/N GS24600 Series*

---

### **USER MANUAL - CONTENTS**

1. INTRODUCTION .....	3
2. SAFETY CONSIDERATIONS .....	6
3. SPECIFICATIONS OF ATMOS GAS CELLS.....	9
4. CHECKLIST .....	12
5. OPTICAL LAYOUT OF THE ATMOS GAS CELLS .....	13
6. INSTALLATION AND ALIGNMENT IN A SPECTROMETER .....	16
7. ATMOS GAS CELL BODIES.....	25
8. ATMOS GAS CELL WINDOWS .....	31
9. MIRRORS WITHIN THE ATMOS GAS CELL BODY .....	45
10. CLEANING/CARE OF ATMOS GAS CELLS.....	54
11. SPARES FOR THE ATMOS GAS CELL .....	58

© July 2018 Specac Ltd. All rights reserved.  
Brilliant Spectroscopy is a trademark of Specac Ltd.  
Other product names mentioned herein may be trademarks  
of their respective owners.

# 1. Introduction

---

Thank you for purchasing a Specac Product.

The Atmos Series gas cells are a range of long pathlength gas cells available as A2.5 (P/N GS24602), A5 (P/N GS24605), A10 (P/N GS24610) and A20 (P/N GS24620) versions for the measurement of gases/vapours at unit ppm levels of their concentration by IR transmission spectroscopy.

A configured Atmos A2.5 gas cell has a **fixed pathlength** of 2.5m.  
A configured Atmos A5 gas cell has a **fixed pathlength** of 5.0m.  
A configured Atmos A10 gas cell has a **fixed pathlength** of 10.0m.  
A configured Atmos A20 gas cell has a **fixed pathlength** of 20.0m.

The range of Atmos gas cells are supplied with **the following standard features**:

- A nickel coated aluminium metal body capable for use up to 125psi pressure.
- Protected, gold coated, polished stainless steel mirrors.
- A fixed pathlength between the internal mirror optical components as stated for each version and size of gas cell.
- Open ended ¼" O.D stainless steel inlet and outlet gas flow tubes for connectivity.
- A purgeable transfer optical unit interface.
- Lever-lock baseplate compatibility.

The Atmos gas cells **can be configured for a build** incorporating the standard features from the following options.

- Choice of CaF<sub>2</sub> (**C**) or ZnSe (**Z**) windows for fitting.
- Choice of Viton (**V**) or Kalrez (**X**) O-ring seals throughout.
- Fitting of on/off Swagelok valve taps and barbed hose tube connectivity to the inlet and outlet gas flow tubes (P/N GS24161).
- Fitting of a low or a high-pressure gauge kit (P/N GS24160).

**Note:** *With the addition of the Atmos gas cells own dedicated heating system, the Atmos gas cell can be operated to a temperature of 200°C for measurement of gases/vapours.*

The actual part number of the Atmos gas cell received refers to the configuration of the gas cell from the **optional components fitted**, related to the coded lettering suffix to the cells individual part number.

Hence, an Atmos gas cell with P/N GS24605CX identifies an Atmos A5 size gas cell with CaF2 windows and Kalrez O-ring seals as supplied.

Another example as P/N GS24610ZV, identifies an Atmos A10 size gas cell with ZnSe windows and Viton O-ring seals as supplied.

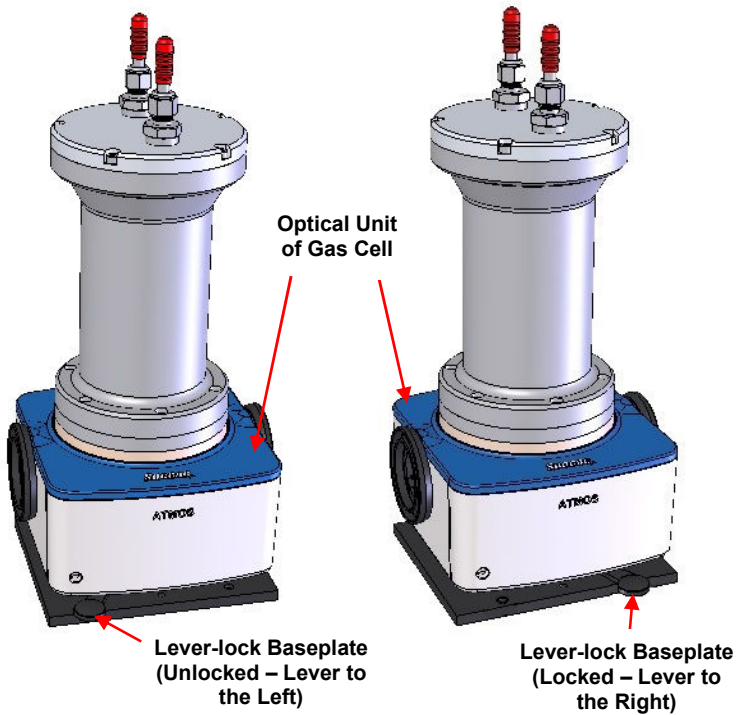

**Atmos Gas Cell Fitted to a Lever-lock Baseplate**

## Atmos Long Pathlength Gas Cells

Please also note the part number configuration of the Atmos gas cell supplied **does not** refer to a specific FTIR spectrometer system into which the gas cell can be installed. Installation of the Atmos gas cell into a spectrometer is via the use of a specific **Lever-lock** adapter baseplate that is fitted into the spectrometer to provide a base platform. (See page 16.)

The Lever-lock baseplate for a specific make and model of spectrometer should be requested at the time of ordering of a specific configuration of Atmos gas cell and it will be supplied with the gas cell.

## 2. Safety Considerations

---

With use of any spectroscopic accessory that involves the study of a wide range of chemical samples, the associated risk in handling may mostly be attributed to the specific sample type to be handled itself. As far as it possible you should follow a procedure for safe handling and containment of the type of sample to be used.

With respect to safety of use specifically for the Atmos gas cells, apart from taking necessary precautions when using the gas cell with pressurized gases and/or heating to elevated temperatures, different window materials can be used for containment of a specific gaseous/vapour type within a nickel coated aluminium body for the gas cell itself. As standard,  $\text{CaF}_2$  and ZnSe windows are the window materials of choice that can be used.



**Caution:** *Between these two different window types, ZnSe is the most potentially hazardous material with respect to toxicity risk in use and handling.*

$\text{CaF}_2$  window material can be considered relatively safe to use, although this material may be harmful to the body if ingested in significant quantity. The general rule when working with **any** window/crystal material (and sample) **is to always wear gloves and safety gear** (e.g. safety spectacles) when handling to obviate the risk of contact with the skin.

Provided with either choice of window material that can be fitted for use in the Atmos gas cell is a window material safety data sheet for the specific material itself. The datasheet can be consulted for safe handling of the window material. A copy of each of these datasheets can also be found in this User Instruction Manual in the **Notes On Cleaning** Section found on pages 54 to 57.

## Hazardous Samples



Any Atmos A20 gas cell with a metal body must not be used above 6.96 bar g (101psi) when using a hazardous sample.

### Definition of a Hazardous Sample

A hazardous sample is defined as a gas (or liquid with a vapour pressure > 0.5 bar g at maximum operating temperature), with a hazard classification shown in the table below or any substance or mixture whose flashpoint is below maximum operating temperature.

The following table defines hazard classification as per Regulation (EC) No 1272/2008. (Applicable Hazard Statement Codes given for reference.)

<b>Hazard Class and Category</b>	<b>Hazard Statement Codes</b>
Unstable explosives or explosives of divisions 1.1, 1.2, 1.3, 1.4 and 1.5	H200, H201, H203, H204, H205
Flammable gases, category 1 and 2	H220, H221
Oxidising gases, category 1	H270
Flammable liquids, category 1, 2 and 3*	H224, H225, H226*
Flammable solids category 1 and 2	H228
Self-reactive substances and mixtures type A to F, or organic peroxides type A to F	H240, H241, H242
Pyrophoric liquids or solids, category 1	H250
Substances and mixtures which in contact with water emit flammable gases, category 1, 2 and 3	H260, H261
Oxidising liquids or solids, category 1, 2 and 3	H271, H272
Acute oral toxicity, category 1 and 2	H300
Acute dermal toxicity, category 1 and 2	H310

\* Where flashpoint is below max operating temperature.

## User Manual

The following flow chart can help to identify whether a sample is defined as hazardous, in relation to the hazard classification table.

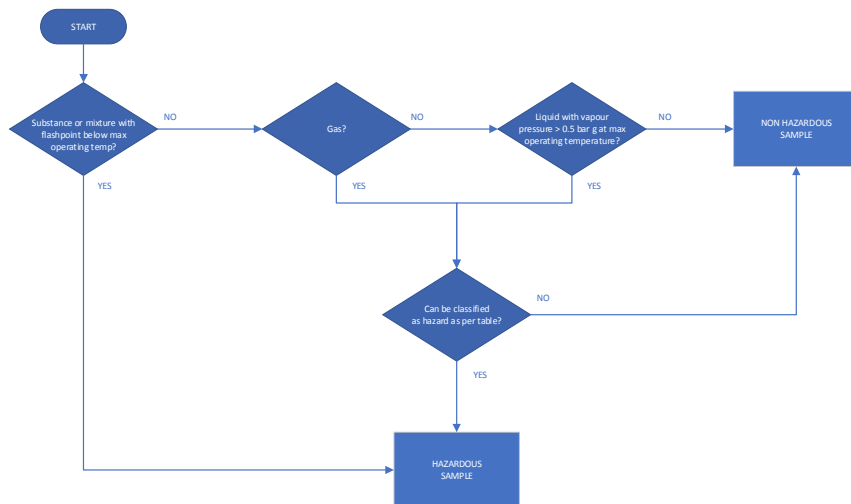

### 3. Specifications of Atmos Gas Cells

---

The Atmos gas cells are supplied as A2.5, A5, A10 and A20 versions for their overall size in terms of volume of cell and the pathlength as fixed for the size of cell. The smallest volume is for the A2.5 cell and the largest volume is for the A20 cell. The shortest pathlength offered is 2.5 metres with the A2.5 Cell and the longest pathlength is 20.0 metres with the A20 gas cell.

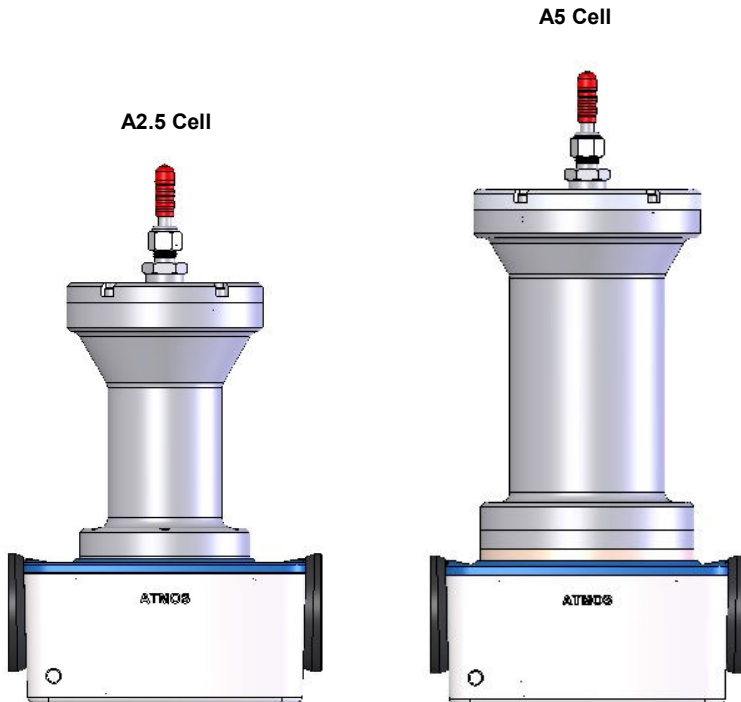

**Fig 1. Front View of Atmos Gas Cells, A2.5 and A5 Versions Comparison for Their Relative Sizes/Dimensions**

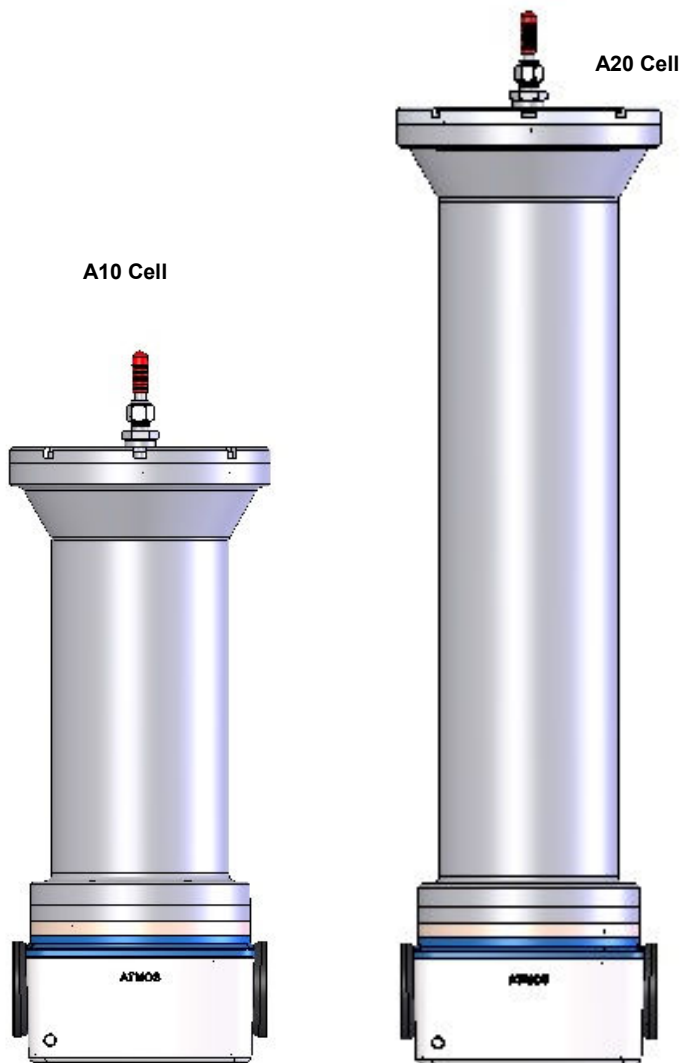

**Fig 2. Front View of Atmos Gas Cells, A10 and A20 Versions Comparison for Their Relative Sizes/Dimensions**

### Dimensions of the Atmos Gas Cells

	Overall Height	Height from optical unit top surface	Top of cell diameter	Cell body diameter	Width at optical unit
<b>A2.5 Cell</b>	265mm	196mm	97mm	56.4mm	154.1mm
<b>A5 Cell</b>	313mm	244mm	112mm	76.2mm	154.1mm
<b>A10 Cell</b>	433mm	364mm	159mm	108mm	154.1mm
<b>A20 Cell</b>	639mm	570mm	159mm	108mm	154.1mm

### Volume to Pathlength Options of the Atmos Gas Cells

	Pathlength	Base Pathlength	Number of Beam Passes	Volume
<b>A2.5 Cell</b>	2.5m	104mm	24	0.25 litres
<b>A5 Cell</b>	5.0m	139mm	36	0.59 litres
<b>A10 Cell</b>	10.0m	250mm	40	2.02 litres
<b>A20 Cell</b>	20.0m	455mm	44	3.59 litres

“Base Pathlength” is defined as the distance between the two objective mirrors at the top and the circular field mirror at the base of the mirror carriage frame on the Atmos gas cell. A calculation using the base pathlength of a specific Atmos gas cell and the **actual fixed pathlength** as offered by the gas cell defines the **number of reflection events** on the internal mirror surfaces for an IR light beam passage within the Atmos gas cell.

e.g. Taking the A5 cell as an example, the 5m fixed pathlength divided by the base pathlength of 0.139m equates to 36 reflection events within the gas cell.

### Vacuum Testing

All Atmos gas cells have been rated to a vacuum of  $3 \times 10^{-3}$  Torr ( $4 \times 10^{-3}$  mbar). The leak rates of the cells are typically:

A2.5 Cell  $6.4 \times 10^{-5}$  Torr liters / Sec ( $8.5 \times 10^{-5}$  mbar liters / sec)

A5 Cell  $2.3 \times 10^{-5}$  Torr liters / Sec ( $3.0 \times 10^{-5}$  mbar liters / sec)

A10 Cell  $3.0 \times 10^{-5}$  Torr liters / Sec ( $4.0 \times 10^{-5}$  mbar liters / sec)

A20 Cell  $3.0 \times 10^{-5}$  Torr liters / Sec ( $4.0 \times 10^{-5}$  mbar liters / sec)

1 Torr = 1.333 mbar

## 4. Checklist

---

On receipt of your Atmos gas cell please check that the following have been supplied:

- An Atmos gas cell variant configured as standard with options of CaF<sub>2</sub> or ZnSe windows and Viton or Kalrez seals.
- A low or high-pressure gauge kit P/N GS24160 (if ordered).
- Swagelok connection inlet and outlet valve taps and barbed hose connections P/N G24161 (if ordered).
- Set of hexagonal ball drivers:  
3.0 mm A/F, 2.5 mm A/F, 2.0 mm A/F, 1.5mm A/F
- Window clamping ring tool.
- Lever-lock baseplate for your spectrometer.
- Lever-lock baseplate installation guide instruction manual.
- Purge bellows P/N GS10707 (if ordered) for transfer optical unit.
- An Essential Spares Kit for Atmos gas cells. (P/N GS24625 – for A2.5 and A5 and P/N GS24626 for A10 and A20.).
- Spectral throughput trace for your configured Atmos gas cell.

Carefully remove the Atmos gas cell and all other parts from their packaging.

The Atmos gas cell supplied will be vacuum wrapped in an aluminium/silver foil bag to prevent any moisture or dust etc, affecting the optics (windows and mirrors) during transportation. Remove the foil bag by carefully cutting at the base of the gas cell and sliding up and away over the Atmos gas cell itself. By cutting the bag carefully, if desired it may be possible to use the foil bag for recovering the gas cell when stored away in its carry case when not in use.

## 5. Optical Layout of the Atmos Gas Cells

The optical layout of the Atmos gas cells is shown in **Fig 3**. The infrared beam is reflected within the cell by the 'White' three mirror cell system (as devised by J.U. White in 1942). This system gives multiple passing in increments of 4 passes. The three mirror surfaces are all spherical, each with the same radius of curvature. The radius is determined from the base pathlength of the cell. **Fig 3**. shows the basic set of a minimum of 4 passes within an Atmos gas cell which completes a beam passage through the gas cell. A combination of the base pathlength multiplied by the number of passes through the gas cell determines the pathlength.

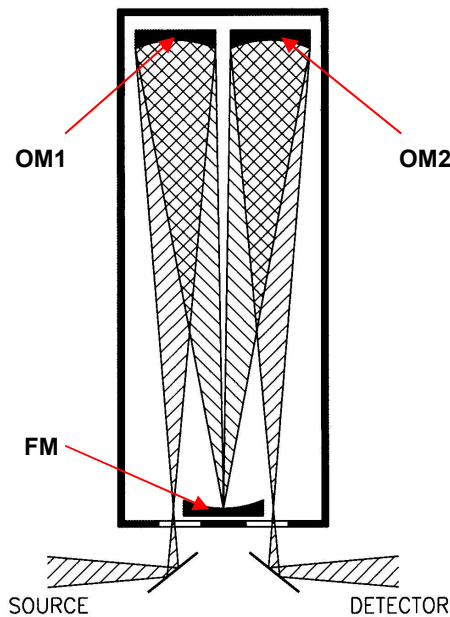
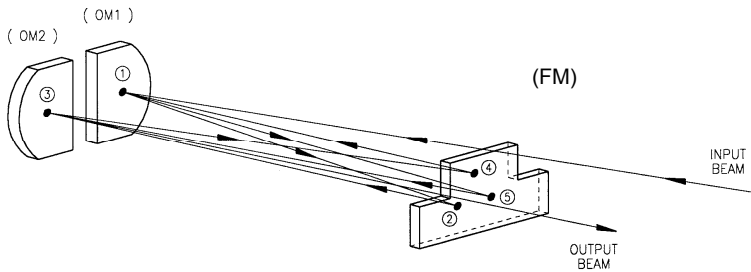

**Fig 3: Optical Layout of Atmos Gas Cells**

The radiation from the source is deflected via the transfer optics input mirror through the cell aperture window into the gas cell. From there, the diverging beam passes to the first objective mirror (**OM1**) which then focuses an image onto the circular shaped field mirror (**FM**) at the base of the gas cell. The beam is returned, diverging to the second objective mirror (**OM2**) which in turn directs it out of the cell to the transfer optics output mirror and on to the detector, or back to the field mirror (**FM**) for additional multiple passes and reflections of the light beam from the mirrors. (Multi-passing.)

## Multi-passing

When there are more than 4 passes of the beam in the Atmos gas cell, the images will line up on the field mirror (**FM**) in 2 rows, as shown in the example for a beam passage diagram from **Fig 4**. The actual pathlength of the gas cell will be the number of passes of the beam multiplied by the base pathlength. (e.g. 36 passes of the A5 gas cell is equivalent to  $36 \times 139\text{mm} = 5000\text{mm} = 5 \text{ metres.}$ )



**Fig 4: The sequence of the beam passes for the spots is:  
Input, (1), (2), (3), (4), (1), (5), (3), Output.**

From **Fig 4**, an input light beam strikes the first objective mirror (**OM1**) and is reflected towards the field mirror (**FM**). The beam passage of light is similarly reflected from the (**FM**) to the second objective mirror (**OM2**). To achieve multi-passing the beam is directed off the second objective mirror (**OM2**) back towards the field mirror (**FM**), on a similar level as the incoming beam. The closer the fourth beam pass image of the sequence is placed to the incoming beam, the more passes of light there will be in the optical system for the gas cell and the pathlength is increased. **Fig 4**, shows a sequence of 8 beam passes with a pattern of 3 spots on the (**FM**) as the next complete set of passes after an initial 4 beam passes to step to the next fixed pathlength. (4, 8, 12, 16, 20, etc.)

**Fig 5**, shows a further example of an image spot pattern on the (**FM**) for 16 passes of a visible light beam (laser light), to establish a fixed pathlength. The pattern for 2 parallel rows of 3 and 4 spot images on a "T" shaped field mirror (**FM**) are as seen from above.

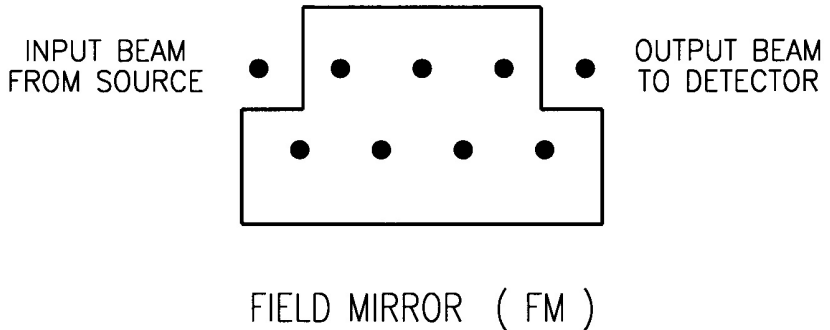

**Fig 5. Light Spot Image Pattern on Field Mirror (FM)**

Using this example, the number of passes of the light beam through the Atmos gas cell can be calculated either by:

1. Counting the **total number of spots** on the **(FM)**, multiplying by 2 and adding 2. e.g. for **seven spots**  $(7 \times 2) + 2 = 16$ .
2. Counting **the greater number of spots within the two rows as seen on the (FM)** and multiplying by 4. e.g.  $4 \times 4 = 16$ .

As the number of passes (and spots) increase, the spots in the rows get closer together.

The Atmos gas cells have been specified for their fixed pathlengths for the number of passes of light beam as follows:

A2.5 Cell – fixed pathlength of 2.5 meters - 24 passes.

A5 Cell – fixed pathlength of 5.0 meters - 36 passes.

A10 Cell – fixed pathlength of 10.0 meters - 40 passes.

A20 Cell – fixed pathlength of 20.0 meters - 44 passes.

## 6. Installation and Alignment in a Spectrometer

---

### Installation Using the Lever-lock Baseplate

The Atmos gas cell is supplied with its own transfer optical unit assembly (1). This mounts directly to any Lever-lock baseplate by location of a slot on the underside of the optical unit (1) over the central pull-down tab mechanism (2) of the Lever-lock baseplate design. (See Fig 6.) This way of installation means that the Atmos gas cell can be used in any FTIR spectrometer fitted with an appropriate Lever-lock baseplate.

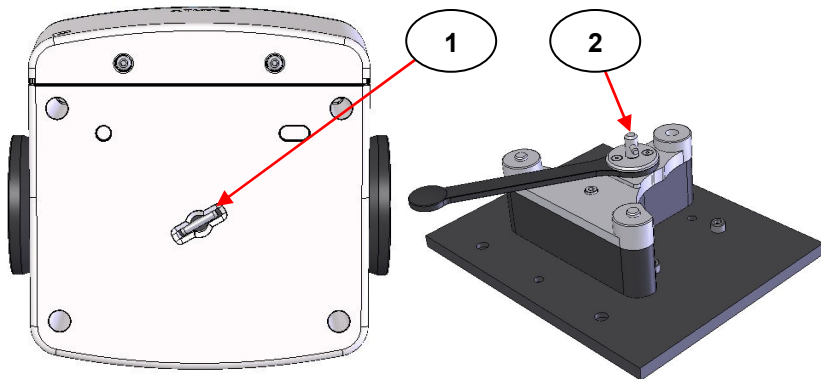

**Fig 6. Underside View of Atmos Gas Cell Optical Unit Showing Lever-lock Baseplate Tab Location Slot**

For installation of the Lever-lock baseplate supplied for your spectrometer please refer to the separate Lever-lock baseplate installation guide instruction manual provided with the gas cell. Once the Lever-lock baseplate is installed, the Atmos gas cell can be mounted to the baseplate.

## Fine Alignment of the Atmos Gas Cell

The configured Atmos gas cell as supplied is factory aligned before despatch for a specified throughput performance and ***should not require any further adjustment of the optical components*** when installed into a spectrometer via use of the Lever-lock baseplate.

However, if an ***optimum performance*** is necessary it will require fine alignment tuning in the specific spectrometer into which it is to be installed and used. Fine alignment is achieved by adjusting the mirrors (3) in the optical unit (1). (See Fig 8.) To gain access to the mirrors remove the optical units cover plate (4) by unscrewing the cover plate fixing screws (5) using the Allen key tool supplied (See Fig 7.)

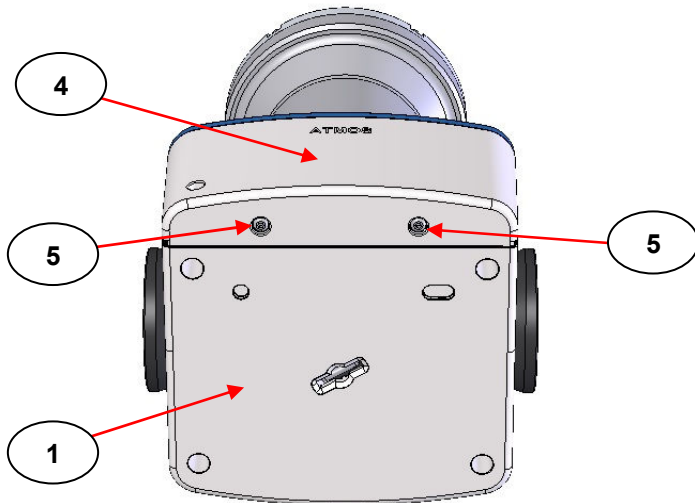

**Fig 7. Atmos Gas Cell Optical Unit Cover Plate and Cover Plate Fixing Screws**

The cover plate screws (5) when loosened are held within the cover plate (4) by captive screw fittings. When the screws (5) are loosened sufficiently the cover plate (4) is carefully pulled slightly up and away from the optical unit (1).

**Note:** To gain access to the cover plate screws (5) for their removal, **the Atmos gas cell must not be fitted to the Lever-lock baseplate.** Therefore, prior to any initial installation of the Atmos gas cell into the spectrometer for fine alignment, loosen the cover plate screws (5) for removal of the cover plate (4) before fitting to the installed Lever-lock baseplate assembly.

When the cover plate (4) has been removed, fit the Atmos gas cell to the installed Lever-lock baseplate and continue for a fine alignment of the Atmos gas cell.

### Fine Alignment Procedure

The transfer optical unit (1) of the Atmos gas cell is a simple system of two mirrors to deflect the source beam of light into and collect from the gas cell, and then to deflect it to the detector.

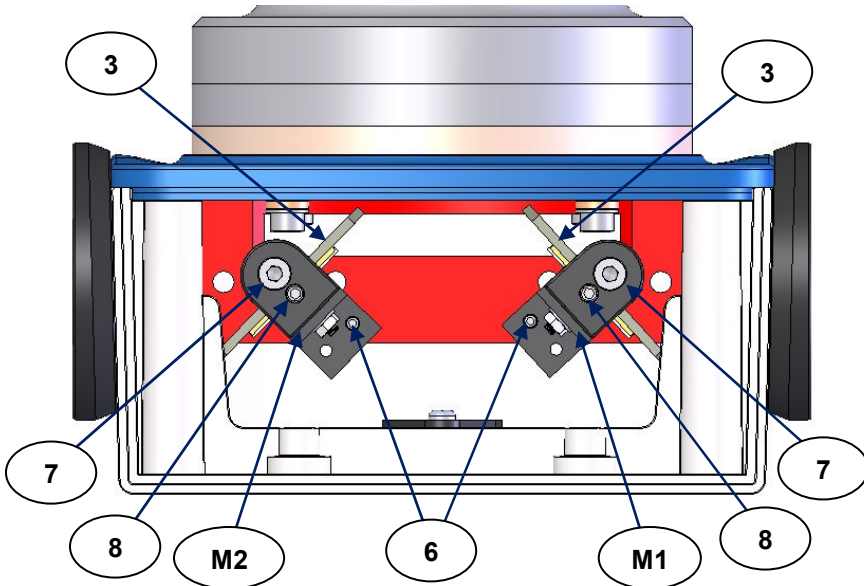

**Fig 8. Transfer Mirror Assemblies in the Atmos Gas Cell Optical Unit with Cover Plate Removed**

**Fig 8.** shows the optical unit (1) with cover plate (4) removed and the internal mirrors (3) on their adjustable mirror carriage assemblies (**M1** and **M2**). The mirror carriage assemblies (**M1** and **M2**) have three adjustable screw fixings (6), (7) and (8). **Fig 9.** shows a close-up detail of these screw fixings.

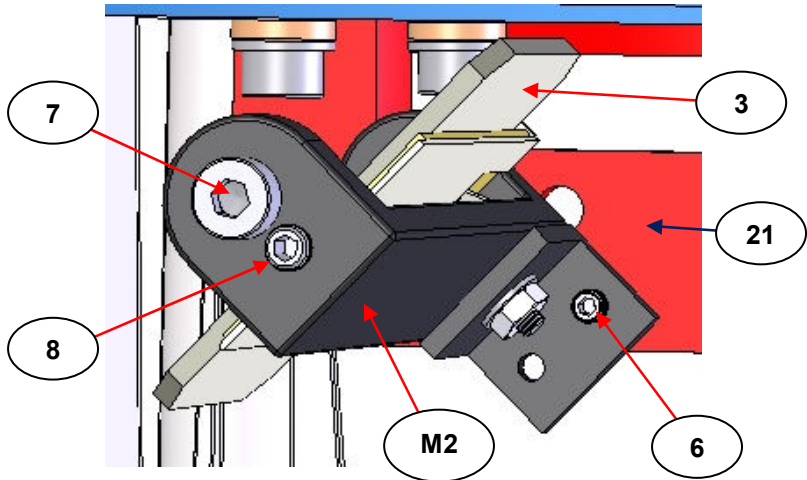

**Fig 9. Detail of M2 Mirror Carriage Assembly - M1 Mirror Carriage Assembly is Identical**

The M3 x 4mm grub screw (6) is used to clamp (lock) the mirror carriage frame assembly (**M2**) into a fixed position to prevent any possible movement of the mirror carriage assembly during transportation. Both (**M1**) and (**M2**) mirror carriage assemblies are factory set for the best throughput characteristics for an initial installation of an Atmos gas cell from new. The grub screws (6) are tightened against the support frame (21) of the mirror carriage assemblies to prevent any movement after the factory alignment. However, **if a fine alignment** of the Atmos gas cell is required for adjustments to the mirror carriage frame settings at an initial installation, the locking grub screw (6) must be loosened first to allow for a rotational movement of the mirror carriage frame assemblies (**M1**) and (**M2**).

From **Fig 9**, the M4 x 5mm cap head screw (**7**) is used **to rotate** the mirror (**3**) surface. The M4 x 12mm grub screw with cone point (**8**) is used **to tilt** the mirror (**3**) surface.

For fine alignment of the Atmos gas cell, the infrared beam direction through the sample compartment determines which mirror carriage assembly (**M1** or **M2**) becomes the **output mirror (3)**. From **Fig 8**, looking from the front of the spectrometer, the source of light to the detector can pass from a left to right (**LR**) or right to left (**RL**) beam direction. For use in a spectrometer with a **LR** beam direction, (**M1**) becomes the output mirror (**3**). For a **RL** beam direction (**M2**) becomes the output mirror (**3**).

**Note:** *When installing a newly supplied, fixed pathlength Atmos gas cell into the spectrometer for the first time there will be some signal throughput registering at the detector to help in a fine alignment of the optical components, if a fine alignment procedure is necessary. For a typical fine alignment procedure as follows, an **RL** beam direction has been used with (**M2**) becoming the **output mirror (3)**.*

Having first loosened the looking grub screw (**6**), using any appropriate beam energy monitoring signal from the FTIR spectrometer itself, adjust the (**M2**) output mirror (**3**) initially **for its rotation only**, turning screw (**7**) clockwise or anticlockwise with the supplied Allen key tool. An improvement in the overall signal at the detector from rotation of the mirror (**3**) in either direction may be observed. If you move away from a peak maximum throughput reading by clockwise rotation, stop and slowly rotate the screw (**7**) in the opposite direction. When a peak maximum throughput reading has been reached, leave the mirror (**3**) at the new rotated setting.

Now, adjust the (**M2**) output mirror (**3**) for **its angle of tilt** by turning the grub screw (**8**) clockwise or anticlockwise using the supplied Allen key tool and observe the throughput signal reading. Similarly, if by clockwise rotation the peak maximum reduces, then rotate the grub screw (**8**) in the opposite direction.

When an optimum peak reading for the pathlength setting of the Atmos gas cell in your spectrometer system has been achieved from rotational and tilt adjustments of the **output mirror (M2) alone**, the Atmos gas cell can be considered correctly aligned. However, it may be possible *to improve the overall throughput* by slight adjustment of the **input mirror (M1)** assembly now, from similar rotation and tilt adjustments of this mirror (3) from the screws (7) and (8) respectively. Please note that the locking grub screw (6) for the (M1) mirror carriage assembly will also need to be loosened first to carry out any positional adjustments of the input mirror (M1).

**Important:** *When making any adjustment to either the M2 (output) or M1 (input) mirror (3), complete the action by bringing back to an optimum peak signal reading before moving to the other mirror (3) for further adjustment.*

If an alteration is made to the setting of the **input mirror (M1)** during a fine alignment procedure, it may then be necessary to readjust the **output mirror (M2)** again for rotation and tilt to get a fine “balance” for both mirror (3) settings within the optical unit (1) alone for an optimum throughput of light signal.

When an optimum alignment of the Atmos gas cell has been achieved from a slight repositioning of the mirror assemblies (M1 and M2), retighten their respective locking grub screws (6) to prevent any further movement away from their optimum alignment position for the spectrometer being used. **DO NOT** overtighten the locking screws (6) as this may affect the mirrors (3) for their alignment positioning. Specac recommend that the screws (6) are tightened whilst the Atmos gas cell is being monitored for its throughput performance as installed in the spectrometer.

Refit the removed cover plate (4) to the optical unit (1). It will be necessary to remove the Atmos gas cell and optical unit (1) from the Lever-lock baseplate to refit the front cover (4). Carefully reposition the cover plate (4) back into position and tighten the cover plate screws (5) sufficiently to hold. Refit the optical unit (1) and Atmos gas cell to the Lever-lock baseplate and the gas cell is ready to use.

## Features on the Optical Unit

There are features on the optical unit (1) of the Atmos gas cell that allow it to be operated in a purged environment (i.e. filling the optical unit with N<sub>2</sub> (Nitrogen) gas), if using a spectrometer with sealed optics.

At the front of the optical unit (1), there is a hole (9) on the front cover plate (4). (See Fig 10.) For a non-purged operation, this hole (9) is open to the local environment from installation of the Atmos gas cell into a spectrometer sample compartment. To purge the internal environment of the optical unit (1) with a flow of N<sub>2</sub> gas, flexible purge tubing (silicone rubber) with a ¼" (6mm) O.D. can be connected through the hole (8). The tubing is simply pushed through the hole (9) and gripped in place to provide a purge gas supply. The cover plate (4) is not removed to purge the optical unit.

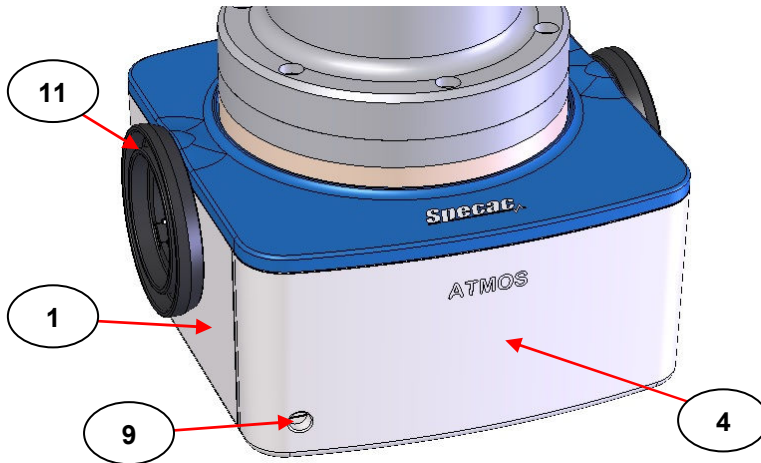

**Fig 10. Purge Hole on Optical Unit of Atmos Gas Cells**

When appropriate tubing is connected, establish a flow of N<sub>2</sub> gas to purge the optical unit (1) free of any residual atmospheric conditions (air, water vapour, excess CO<sub>2</sub> etc). Purging the optical unit (1) with N<sub>2</sub> gas can help in low level measurements of CO<sub>2</sub> vapour within a gaseous species inside the Atmos gas cell itself.

To allow the optical unit (1) to be purged efficiently when the Atmos gas cell is installed into the sample compartment of a spectrometer, it is necessary to fit the flexible purge bellows (10) that are supplied as Specac P/N GS10707 to the optical unit (1).

**Note:** *It is recommended that purge bellows (10) are fitted during use to help stabilize the instrument background, even if the Atmos gas cell optical unit (1) is not being purged.*

### Fitting Purge Bellows (P/N GS10707) to the Optical Unit

The purge bellows (10) are attached for a push fit *inside* the circular aperture ports (11) at each end of the optical unit (1). (See Figs 10/11.) Note that the end of the purge bellow (10) with the short length stub of circular tubing is inserted into the aperture port (11) of the optical unit.

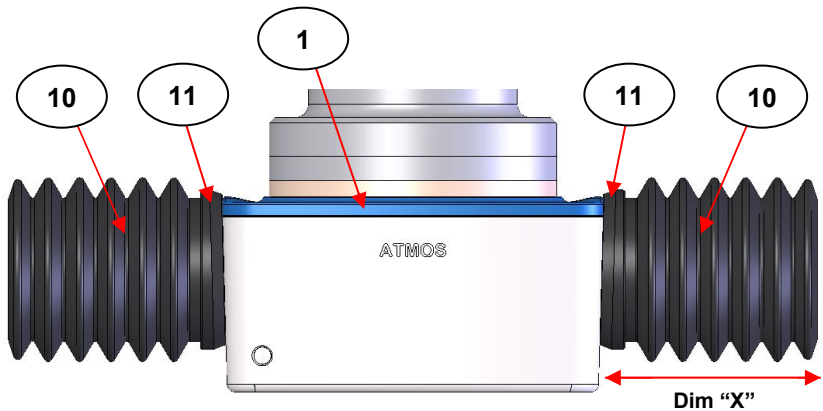

**Fig 11. Purge Bellows (10) Fitted to Atmos Gas Cell Optical Unit**

For certain spectrometers, the purge bellows (10) may need to be cut to a shorter length for a better fit within the sample compartment when fitted to the optical unit (1) and as installed.

## User Manual

With the Lever-lock baseplate secured, and Atmos gas cell installed correctly into position on the Lever-lock baseplate, measure the approximate distance between the spectrometer side walls from the source and detector ports and the flat end surface of the optical unit (1) (Dimension 'X' – see **Fig 11**).

Using a sharp razor blade, take care to cut lengths of the flexible purge bellows (10) which are equivalent to the measured length (X) plus an additional 10 mm for each purge bellow.

**Tip:** *It is easier to cut the purge bellow (10) between the hard ridges.*

Remove the Atmos gas cell away from the Lever-lock baseplate and from the sample compartment. Fit the shortened flexible purge bellows (10) via their short tube stub end into the circular aperture ports (11) (as seen at **Fig 11.**) and compress sufficiently to enable the Atmos gas cell and purge bellow assembly to fit back into the spectrometer on the Lever-lock baseplate.

Ensure the purge bellows (10) are not obstructing the beam and then secure the Atmos gas cell optical unit (1) back onto the Lever-lock baseplate.

## 7. Atmos Gas Cell Body

---

The Atmos gas cell metal body is made from nickel coated aluminum. This material provides for very good resistance to the absorption of acidic vapours, minimising any potential future contamination (memory effects) of residual vapours in the gas cell.

The metal bodied Atmos gas cell fitted with either CaF<sub>2</sub> or ZnSe windows are rated to a pressure holding of 125 psi.

### Top of Gas Cell Body – Fittings and Features

At the top of the body for all the Atmos gas cells in the range, there are some common fittings and features. The range of Atmos gas cells differ in their size for the body with a consequent effect on the volume capacity of the gas cell.

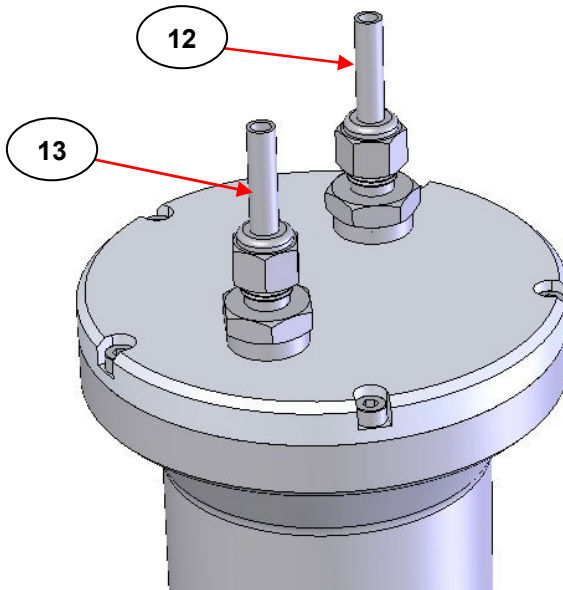

**Fig 12. Top of Atmos Gas Cell – Flow Tube Fittings**

## Inlet and Outlet Gas Flow Tubes

Common to the range of the Atmos gas cells are inlet (12) and outlet (13) gas flow tubes in stainless steel material with a 1/4" O.D. These gas flow tubes are "bare ended" finished at the top of the gas cell body to allow for any type of commercially available gas fittings and tubing to be connected. (See Fig 12. – their red coloured plastic tube covers have been removed for the image.)

The inlet tube (12) passes all the way down through the inside of the Atmos gas cell to exit at the base of the gas cell.

**Note:** *The inlet tube (12) fitting is nearest to the back at the top of the Atmos gas cell when installed into the spectrometer.*

The outlet tube (13) is shorter in length and gases flow into this tube at the top of the gas cell chamber itself. In this way a gas cell is filled from the bottom to the top to enable complete filling of the gas cell for either static or flow measurement purposes.

## Vacuum Gas Cell Inlet and Outlet Tap Valves (P/N GS24161)

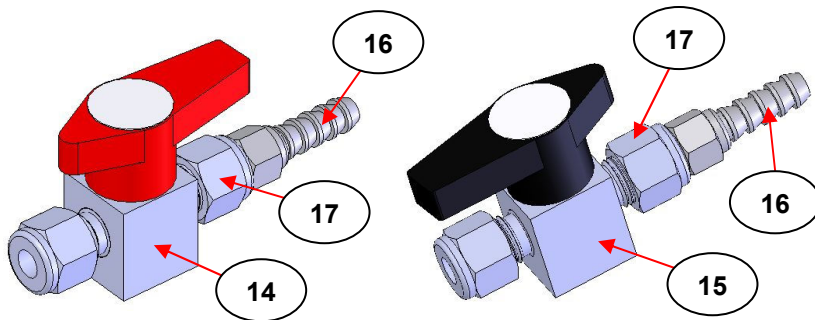

**Fig 13. Gas Cell Inlet (Red Tap) and Outlet (Black Tap) Valves  
Specac P/N GS24161**

**Fig 13.** shows the vacuum gas cell inlet (14) and outlet (15) tap valves and "barbed" hose connection fittings (16) that can be connected to the bare ended 1/4" O.D gas flow tubes of the Atmos gas cell. These tap

parts are available as P/N GS24161. The colour of the taps and their arrow direction when the taps are open indicates the direction of gas flow with the red tap (14) fitted to the inlet (12) and black tap (15) fitted to the outlet (13) gas flow tubes. The Atmos gas cell can be operated in a **flow through mode** for vapour measurement with both valves (14) and (15) open. With these valve taps fitted, to operate the Atmos gas cell in a **static mode** for vapour measurement, allow the gas to fill the cell via the inlet tube (12) with both valves (14) and (15) open. To seal the gas in the gas cell, cease the flow of the gas by closing the outlet valve (15) and then the inlet valve (14) as soon as possible after.

The inlet (14) and outlet (15) tap valves have “barbed” hose type connections (16) for fitting of 1/4" O.D. (or 6mm O.D.) flexible gas tubing. However, the barbed hose type connections (16) can be removed by undoing their fixing nut (17) and replacing with 1/4" O.D stainless steel tubing with olive/ferrule and nut connections for alternative plumbing to an (inlet) gas supply and (outlet) gas flow or vacuum pump facility.

### Pressure Gauge Kits (P/N GS24160)

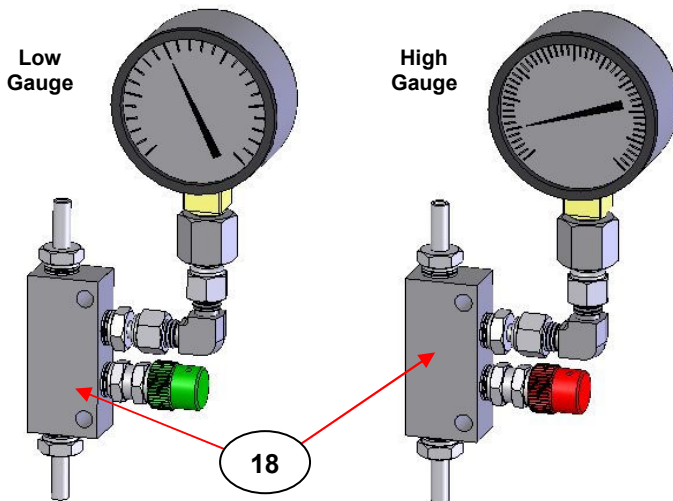

Fig 14. Low and High-Pressure Gauge Kits P/N GS24160

For all the Atmos gas cell variants, a low or high-pressure gauge kit P/N GS24160 can be purchased to fit for measurement of the gas pressure within the gas cell environment. (See **Fig 14.**)

The low-pressure gauge is rated up to a maximum operating pressure of 1 bar g (14.7psi), whereas the high-pressure gauge is rated up to 8.5 bar g (125psi.) The Atmos gas cells having a nickel coated aluminium metal body are rated to a 8.5 bar g (125psi) pressure maximum, so either the low or high-pressure gauge kit can be fitted.

The low or high-pressure gauge kit of parts (**18**) is fitted between the top of the outlet gas flow tube (**13**) and the outlet on/off valve tap (**15**), if this tap part has been obtained via P/N GS24161 (See **Fig 13.**).

### Gas Line Connections to the Atmos Gas Cell for Safe Operation

The Atmos gas cells can be used over a temperature range between ambient up to 200°C and for pressures up to 8.5 bar g (125psi) of a gas/vapour. Note the pressure limitation of 6.96 bar g (101psi) when using the A20 Atmos gas cell with hazardous samples. (See page 7.)

Whenever raising the temperature for operation of any Atmos gas cell, it is highly recommended to have **a pressure safety device** plumbed into a gas line connection that is made to the **outlet** gas tube (**13**).

The low or high-pressure gauge kit of parts (P/N GS24160) ideally should be fitted to the Atmos gas cell to facilitate the inclusion of a pressure gauge indicator along with an over-pressure event safety line that can be vented to a safe place of containment (e.g. a fume hood). On the body of the pressure gauge kit (**18**) there is a corresponding set pressure relief valve assembly fitting beneath the low or high-pressure gauge as fitted. Specac suggest and advise that this set pressure relief valve outlet is re-sited to a safe containment area such as a fume hood by fitting an additional and appropriate length of stainless steel tubing between the pressure gauge body and the pressure relief valve. (See schematic **Fig 15.**)

Inclusion of such a pressure safety device with associated gas line connectivity is needed to vent away any potential excess build-up of the pressure in the gas cell chamber area (specifically for a **fixed volume** state of the gas cell – non-flowing experiments), when elevated temperatures from ambient conditions are established from any heating of the Atmos gas cell. Any excess pressure conditions subjected to the gaseous environment created from heating a gas in a fixed volume (e.g. a hot and potentially toxic environment), can be safely diverted away from the gas cell chamber itself to prevent any accidental damage to the CaF<sub>2</sub> or ZnSe windows that have been fitted and/or compromising of the Viton or Kalrez seals as fitted. Failure of the seals and window components under excess pressure risks a release of any gas conditions into the sample compartment of the spectrometer being used and increases the risk to any operator.

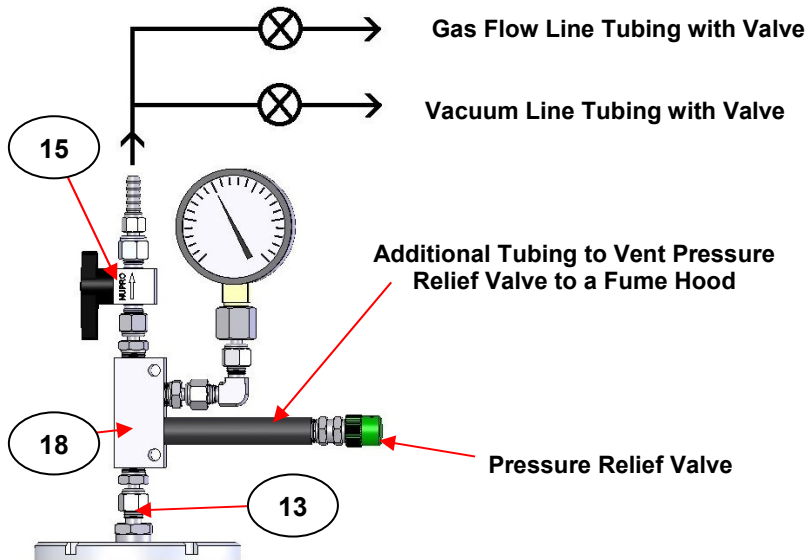

**Fig 15. Schematic for Suggested Safety, Vacuum and Flow Gas Line Connectivity for Safe Operation of Atmos Gas Cells**

As shown in the schematic at **Fig 15**, along with the consideration for safety in operation for any potential over-pressure events, suggested gas line connections have been made from the outlet valve tap connection (**15**) to separate vacuum and flow lines with their own on/off valve taps. Both the safety over pressure line and additional flow line are routed to terminate in a safe containment area such as a fume hood. Any exhaust port(s) from a vacuum pumping system for the vacuum line should also ideally be routed to vent off the gas to a safe area too, such as a fume hood environment.

From connection in this way of these gas lines to an Atmos gas cell and particularly if the gas cell is to be heated, the safety over pressure line at the pressure gauge kit of parts (**18**) as fitted is “open” all the time (no on/off tap/valve is incorporated in the safety line). This is a safe set up if the gas cell is to be used in a static or flow mode of operation for gas conditions or if there is a need to evacuate the gas cell using a vacuum pump line.

Depending upon the circumstances of operation needed for the Atmos gas cell (at ambient or elevated temperature conditions), the valve taps on the outlet valve (**15**), vacuum line and flow line can be opened or closed accordingly to control the pressure and allow for safe operation of the equipment. The setting of the valve taps as open or shut can be tabulated as follows for specific experimental conditions with regards as to which line is operable.

<b>Gas Cell Operating Condition</b>	<b>Outlet Valve Assembly (15)</b>	<b>Valve on Flow Line</b>	<b>Valve on Vacuum Line</b>
<b>Over Pressure Monitoring</b>	<b>Open or Shut</b>	<b>Open or Shut</b>	<b>Open or Shut</b>
<b>Gas Flow</b>	<b>Open</b>	<b>Open</b>	<b>Shut</b>
<b>Vacuum</b>	<b>Open</b>	<b>Shut</b>	<b>Open</b>

## 8. Atmos Gas Cell Windows

---

CaF<sub>2</sub> (**C**) or ZnSe (**Z**) windows are used as standard in the Atmos gas cells. (Other window materials may be supplied if specially requested by contacting Specac.)

For all sizes of Atmos gas cells there are **two** windows used at the base of the gas cell. One window allows for an input beam of light from the optical units **input** mirror (**3**) to reach the **OM1** and the other window allows for an output beam of light from the **OM2** to pass through to the optical units **output** mirror (**3**).

The “nominal” window dimensions for each gas cell are shown in the following table.

Gas Cell	CaF <sub>2</sub> Window P/N GS24628	ZnSe Window P/N GS24627
Atmos A2.5 P/N GS24602	25mm dia x 5mm thick (2)	25mm dia x 5mm thick (2)
Atmos A5 P/N GS24605	25mm dia x 5mm thick (2)	25mm dia x 5mm thick (2)
Atmos A10 P/N GS24610	25mm dia x 5mm thick (2)	25mm dia x 5mm thick (2)
Atmos A20 P/N GS24620	25mm dia x 5mm thick (2)	25mm dia x 5mm thick (2)

The windows are sealed into position by use of an O-ring (**33**), PTFE gasket (**32**), PEEK gasket (**31**) and clamp ring assembly (**23**). It may be necessary to gain access to the windows to:

- 1) Change them in the gas cell for a different window material.
- 2) Replace the windows because they have become damaged.
- 3) Clean the windows because they have become contaminated.

The procedure to gain access to the windows is similar for **all** the Atmos gas cells. The A5 size Atmos gas cell has been used as an example to follow in the window access procedure.

## Window Access for an Atmos Gas Cell

This procedure is followed for both a CaF<sub>2</sub> (C) or ZnSe (Z) window configured build of Atmos gas cell. Specac recommend the wearing of gloves to prevent touching the window material and causing contamination when handling. The instructions apply to all Atmos gas cells, but there are specific steps to follow for the A2.5 size gas cell as seen from pages 42 to 44.

### Separating the Atmos Gas Cell Assembly from its Optical Unit

The Atmos gas cell must be separated from any Lever-lock baseplate attachment and then laid over carefully onto the back-side surface of the optical unit (1) on a secure work bench area. Remove the cover plate (4) as described from pages 17 and 18.

**Fig 16.** shows an underside view of the optical unit (1) with the cover plate (4) removed to gain access to the four M3 x 10mm cap head fixing screws (19) that are undone to separate the top surface (20) of the optical unit attached to the metal bodied (M) gas cell assembly away from the optical units (1) moulded box assembly.

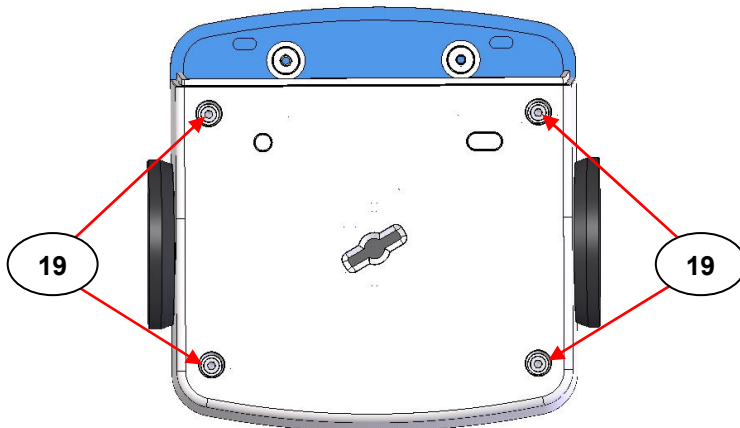

**Fig 16. Atmos Gas Cell Fixing Screws to Separate Gas Cell Body from the Optical Unit**

Using the Allen head ball driver tool supplied, undo the four screws (19) by turning them anticlockwise and carefully separate the optical unit box (1) away from the top section (20) that carries the metal body gas cell assembly. The resulting gas cell assembly of parts to gain access to the windows is seen as Fig 17.

**Note:** Be careful when separating the parts as the optical transfer mirrors (3) (as (M1) and (M2)), will be attached to the underside of the top section (20) of the optical unit on their mirror carriage frame (21). Avoid touching these mirror assembly components which have been set for an optimum alignment of throughput energy passing into and out of the gas cell when operating.

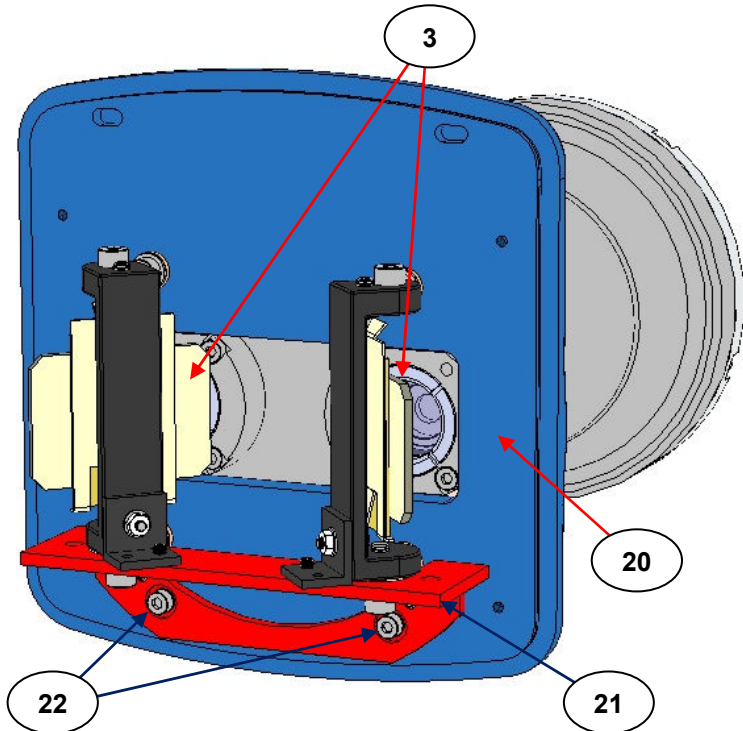

**Fig 17. Separated Top Section and Gas Cell Body Assembly away from the Optical Unit Moulded Box**

To gain access to the window clamping rings (23) remove the complete mirrors carriage frame assembly (21) by undoing the two M3 x 6mm cap head fixings screws (22) and their spring washers. (See Fig 17.) Use the supplied Allen key tool to remove the screws (22) and very carefully set aside the mirror carriage frame assembly of parts (21) for re-attachment later. The resultant assembly of parts at this stage to gain access to the windows and window clamp rings (23) is seen as Fig 18.

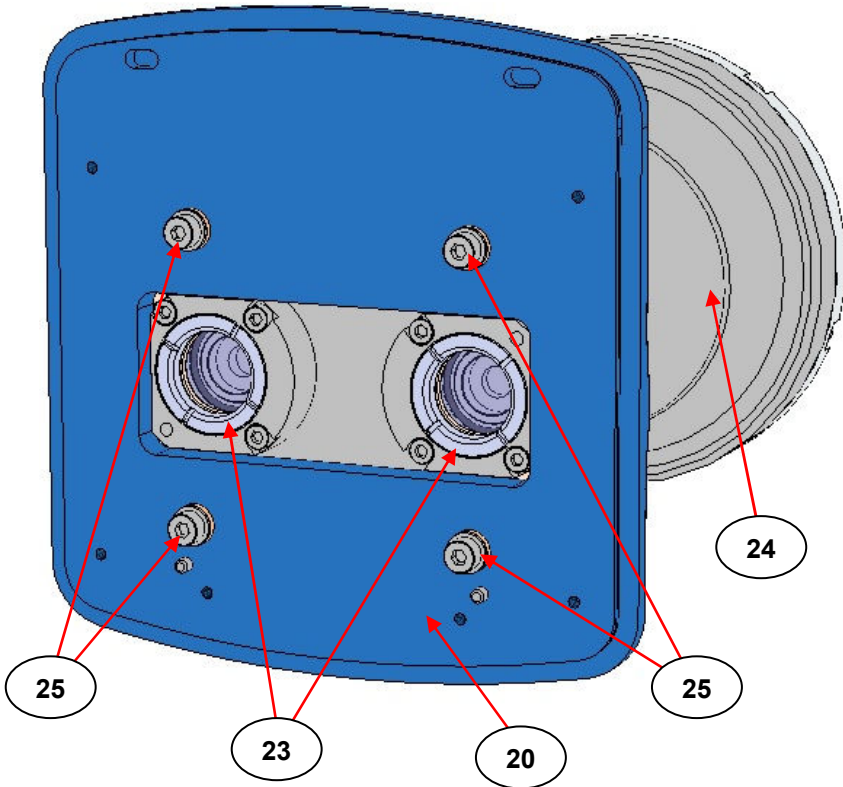
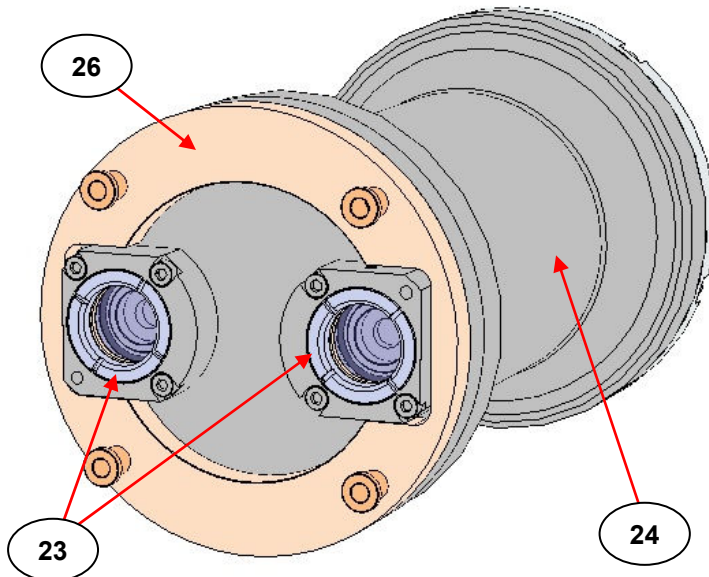

Fig 18. Transfer Mirrors Carriage Frame Assembly (21) removed from the Top Section (20) and Gas Cell Body Assembly (24)

For direct and easier access to the window clamp rings (23) it is now necessary to remove the top section (20) away from the main gas cell body assembly (24). As shown at Fig 18. undo and remove the four M4 x 25mm cap head screws (25) and washers to separate the top section (20) and PEEK heat insulating ring (26) away from the gas cell body (24).

Note which is the top and bottom of the top section (20) from its removal, as on reassembly, it is necessary to refit this part for its correct orientation to the gas cell body assembly (24) for subsequent correct reattachment of the mirror frame assembly (21) and the optical unit moulded box (1). When the top section (20) has been removed, the Atmos gas cell assembly will be as seen at Fig 19. The PEEK heat insulating ring (26) is shown still fitted in position, but this will separate away from the gas cell body (24) if it is not removed along with the top section (20) when this item is removed.



**Fig 19. Top Section (20) Removed from the Gas Cell Body Assembly (24)**

When the PEEK ring (26) is removed, the Atmos gas cell is as shown for Fig 20. to gain access to the windows (27) for their inspection in cleaning and/or replacement.

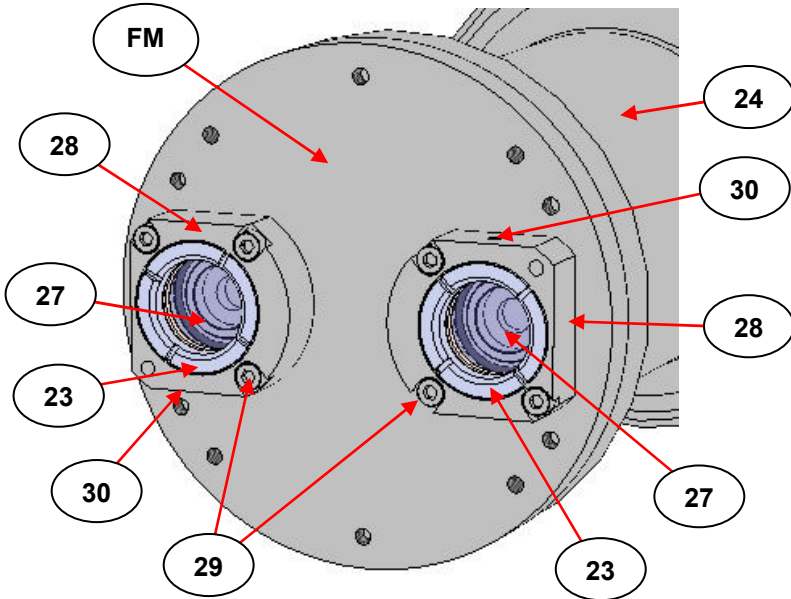
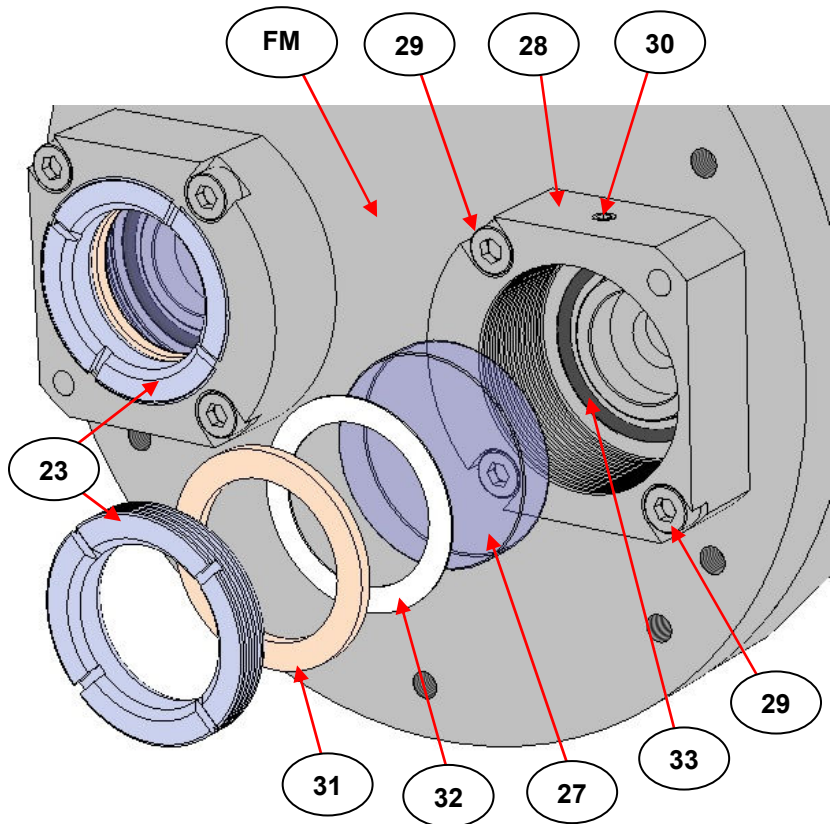

**Fig 20. Top Section (20) and PEEK Ring (26) Removed from the Gas Cell Body Assembly (24)**

**Note:** For dismantling and rebuilding of the window assembly of parts it is important that the Atmos gas cell body is held as vertically as possible with the window end of the gas cell uppermost for the components to fit and align correctly.

Fig 19. shows that there are two identical window housing frame assemblies (28) that are each affixed to the underside plate of the field mirror (FM) using three cap head screws (29). Within the housing frame there is a small M3 x 3mm grub screw (30) that is used to lock the clamping ring (23) into position when a window (27) and its internal O-ring sealing components have been fitted and tightened together.

To remove the clamping ring (23) to gain access to the window (27), the M3 x 3mm grub screw (30) must be loosened using the ball driver tool provided. **Fig 21.** shows close-up detail of a window housing frame assembly (28) and the sequence of the individual components of a window assembly (windows, gaskets and O-ring seals), in the order they are fitted into their aperture recesses *on the underside plate of the field mirror (FM)*. (Note, the grub screw (30) is **on the underside** of the window frame housing (28) on the left side as seen.)



**Fig 21. Window Housing Frame Assembly (28) and Window Components for Sequence of Construction in an Atmos Gas Cell**

With the grub screw (30) loosened by unscrewing it anticlockwise for a complete revolution, use the special window clamping ring tool provided to unscrew and remove the clamping ring (23) away from the window frame housing (28). (See Fig 22).

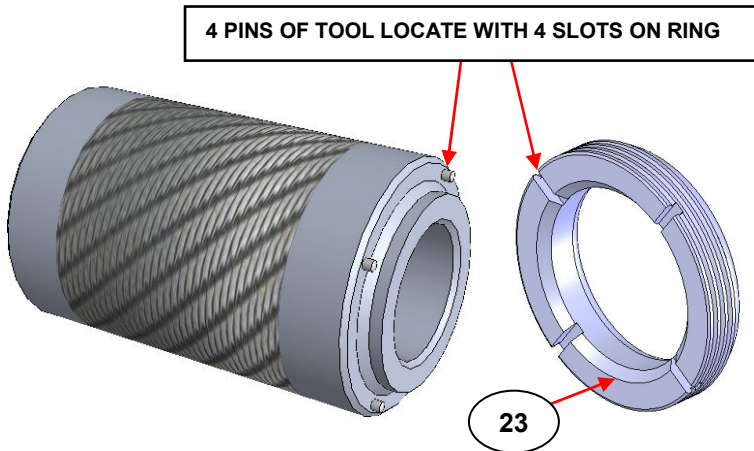

**Fig 22. Window Clamping Ring Tool and Clamping Ring**

For the sequence of construction of window assembly components, underneath the clamping ring (23) there is a PEEK window gasket ring (31) and beneath the PEEK gasket ring (31) is a PTFE gasket ring (32) which is in contact with the outer window surface. Carefully remove these two gaskets (31) and (32) away from the window (27) before removing the window. If using forceps etc, avoid touching the window (27) surface to prevent any scratching or damage to the window material.

## Window Removal

When access has been gained to the window (27) from removal of the clamping ring (23), PEEK (31) and PTFE (32) gasket rings, a suction type pen cup may be used to press carefully against the window surface and lift the window (27) free to pull up and out of the aperture recess.

Underneath the window (27) (for its surface that is exposed to any gas conditions within the actual Atmos gas cell itself), a sealing O-ring (33) is fitted. This O-ring (33) material will be in Viton or Kalrez material as specified from the build configuration of the Atmos gas cell when supplied.

It depends how the window (27) is adhering to the O-ring (33) if a suction type pen cup tool is sufficient to remove the window (27) easily and safely. If the window (27) can be removed from the aperture recess in this way, the O-ring (33) may also be removed from the aperture recess as adhered to the window. If so, check that the window (27) and O-ring (33) parts are undamaged and carefully try to separate these parts using an appropriate solvent if and where necessary. (Check the **Notes On Cleaning** section of this user instruction manual page 54 for correct solvents with either CaF<sub>2</sub> or ZnSe windows where used.)

If the window (27) is freed successfully and the O-ring (33) remains in the aperture recess, it may be necessary to remove the O-ring (33) for inspection and possible cleaning etc, before refitting and re-using. A small, flat-blade screwdriver, or forceps, can be used to carefully prise the O-ring (33) away from the aperture recess, if necessary.

**Note:** *When access has been gained to the sealing O-ring (33) for inspection, Specac recommend that a new O-ring in either Viton or Kalrez material is preferred for use in replacement rather than trying to refurbish a previously used O-ring.*

## Stuck Window

If access has been gained to the window (27) from removal of the clamping ring (23), PEEK gasket ring (31) and PTFE gasket ring (32), **but the window (27) cannot be freed easily using a suction type pen cup**, then it may be necessary to remove the window housing frame (28) such that a better purchase can be attained against the sides of the window (27) itself. **Fig 23.** shows the assembly of the Atmos gas cell when the clamping ring (27), PEEK gasket ring (31) and PTFE gasket ring (32) have been removed from one of the window housing frames (28).

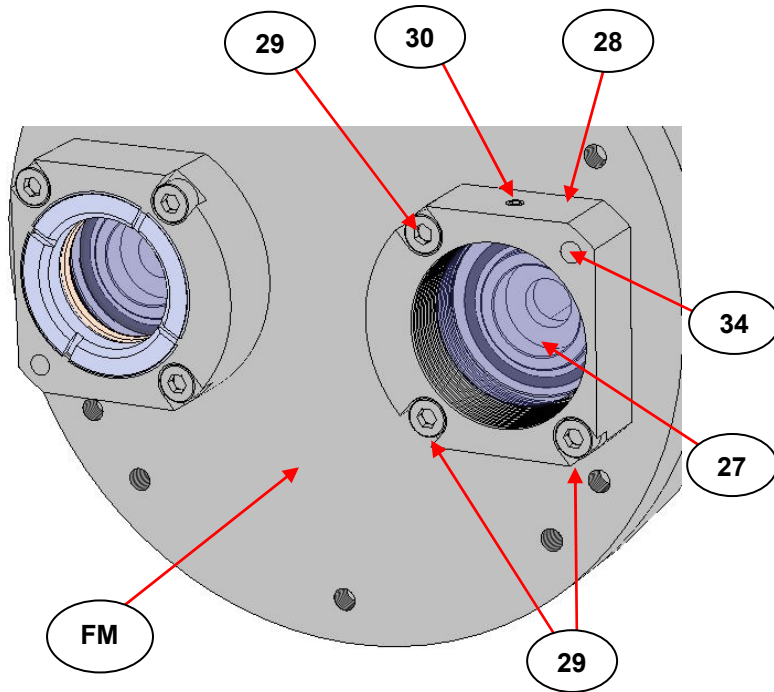

**Fig 23. Window Housing Frame Assembly (28) With Clamping Ring (23), PEEK Ring (31) and PTFE Ring (32) Removed**

Remove the three M3 x 12mm cap head screws (29) using the ball driver key tool provided to separate the window housing frame (28) away from the underside plate surface of the (FM). (If working on the A2.5 Atmos gas cell the screws (29) are **M3 x 8mm** in size.) Note that there is a small hole (34) in the window frame (28) as this orientates the window frame for correct attachment over a small fixed location pin. Very carefully lift-up and pull away the window frame (28), when the three screws (29) have been removed, to separate from the location pin and the internal window (27).

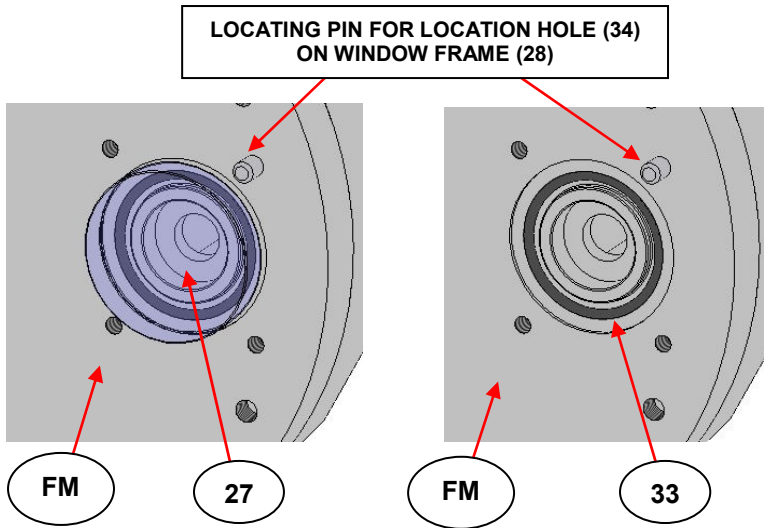

**Fig 24. Window Housing Frame Assembly (28) Removed (Window (27) in Place and then Removed)**

With the window frame (28) removed, **Fig 24.** shows that the window (27) will be sitting proud around its edge to grip for its removal. Wearing safety gloves, very carefully grip the edges of the window and gently manipulate it free. The sealing O-ring (33) may be pulled free too if stuck to the window (27) on its removal, or it may remain within the aperture recess as seen from **Fig 23.** If the O-ring (33) is stuck to the window (27), check that the window (27) and O-ring (33) parts are undamaged and carefully try to separate these parts using an appropriate solvent if and where necessary. (Check the **Notes On Cleaning** section of this user instruction manual page 54 for correct solvents with either CaF<sub>2</sub> or ZnSe windows where used.)

If the window (27) is freed successfully and the O-ring (33) remains in the aperture recess, it may be necessary to remove the O-ring (33) for inspection and possible cleaning etc, before refitting and re-using. A

small, flat-blade screwdriver, or forceps, can be used to carefully prise the O-ring (33) away from the aperture recess, if necessary.

### **Window Assembly Components Inspection and Cleaning**

With the window(s) (27) and component gaskets and O-ring seals (31, 32 and 33) removed from the Atmos gas cell, these items can be inspected for their condition, cleaned for re-use or replaced where necessary. (Please follow the **Notes On Cleaning** section page 54 for correct handling procedures etc.)

Reassembly of the component parts for a rebuilt Atmos gas cell is a reverse operation to the procedures followed from the pages 32 to 41 of this user instruction manual.

### **Special Note for A2.5 Atmos Gas Cell**

If needing to gain access to the windows (27) of the **A2.5 Atmos gas cell**, the same procedures as outlined on pages 32 to 41 are followed as for the A5, A10 and A20 Atmos gas cells.

However, at the stage for separation of the top section (20) from the gas body assembly (24) (see pages 34 and 35), there is an additional step needed for removal of the PEEK heat insulating support ring (26).

**Fig 25.** shows the underside details of the top section (20) as attached to the body assembly (24) of the A2.5 Atmos gas cell. The four M4 x 8mm round head fixing screws (25) are undone and removed similarly as for an A5, A10 or A20 Atmos gas cell to separate the top section (20) away from the gas cell body (24), but the PEEK insulating support ring (26) **is still retained to the gas cell body (24)** by four cap head screw fixings (34). (See **Fig 26.**)

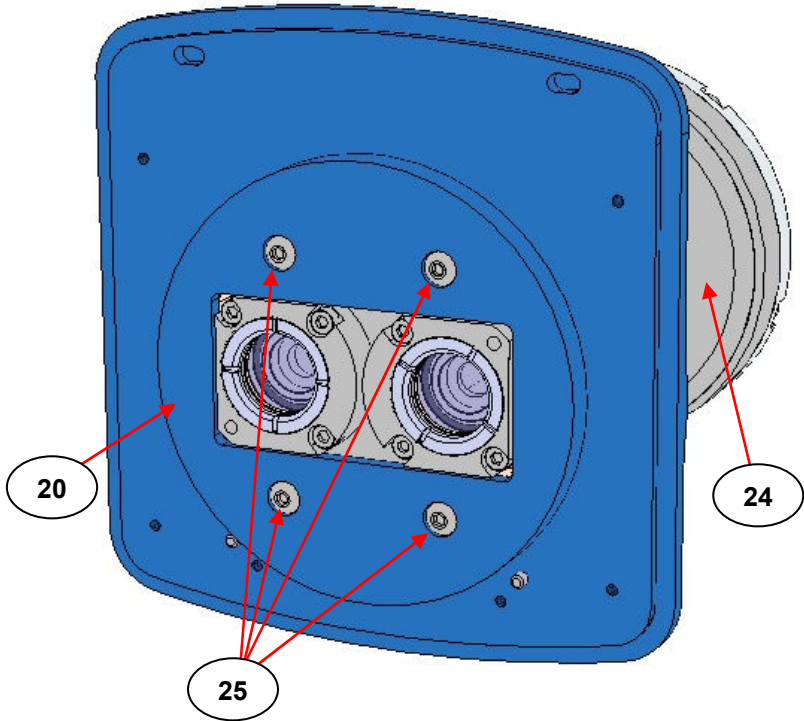

**Fig 25. Top Section (20) Removal from A2.5 Atmos Gas Cell Body Assembly (24)**

**Fig 26.** shows the A2.5 Atmos gas cell assembly (24) when the top section (20) has been removed and when the PEEK support ring (26) has also been removed from loosening and removal of the four M4 x 8mm cap head screws (34). It is necessary to remove the PEEK support ring (26) to gain access to the grub screw (30) on the window housing frame (28). Loosening of the grub screw (30) allows for the window clamping ring (23) to be undone to gain access to the window (27). The procedure for window removal can be continued from page 36 of this user instruction manual as for A5, A10 or A20 Atmos gas cells.

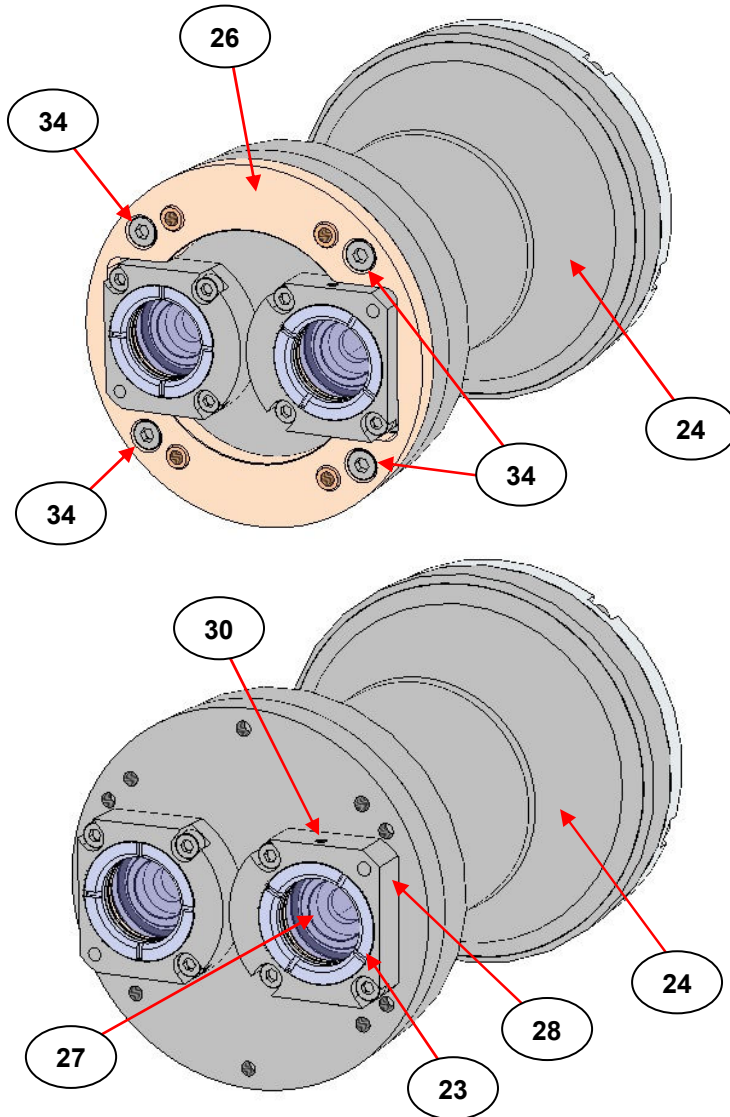
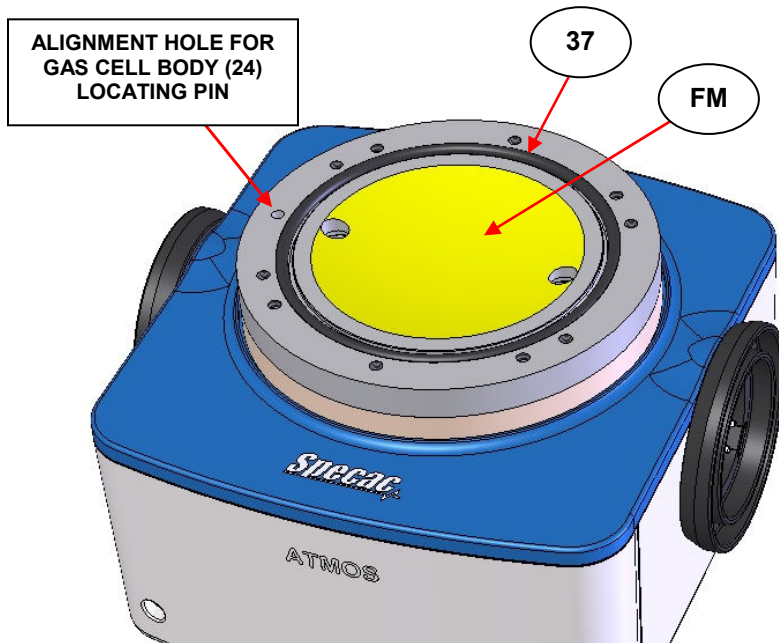

**Fig 26. PEEK Support Ring (26) Removal from A2.5 Atmos Gas Cell Body Assembly (24)**

## 9. Mirrors Within the Atmos Gas Cell Body

All Atmos gas cells are provided with gold coated mirror surfaces on quartz glass supports for the objective mirrors (**OM1** and **OM2**) at the top of the gas cell and the field mirror (**FM**) at the base of the gas cell.

**Fig 27.** shows the field mirror (**FM**) at the base of the Atmos gas cell. (The upper complete Atmos gas cell body assembly (**24**) has been removed for explanation.) The (**FM**) is circular and covers the entire base area of the gas cell. There are two holes in the (**FM**) to allow for the infrared beam of light to pass through the gas cell environment from the windows (**27**) below, for both the inlet and outlet beam passage of light for the pathlength of the gas cell.



**Fig 27. Field Mirror (FM) for the Atmos Gas Cell  
(Gas Cell Body Assembly (24) Removed)**

**Fig 28.** shows two views of the objective mirrors (**OM1**) and (**OM2**) at the top of the Atmos gas cell. (**OM1**) and (**OM2**) are fitted for an aligned and fixed pathlength position to a support bridge part (**35**) that is affixed directly to the metal gas cell body (**24**). The parts are seen with removal of the top cap and flow tube fittings (**12** and **13**) as the **top view** image. With removal of the metal gas cell body (**24**) from the top section of the optical unit (**20**), the gold mirror surfaces can be seen through the length of the gas cell body as the **underside view**.

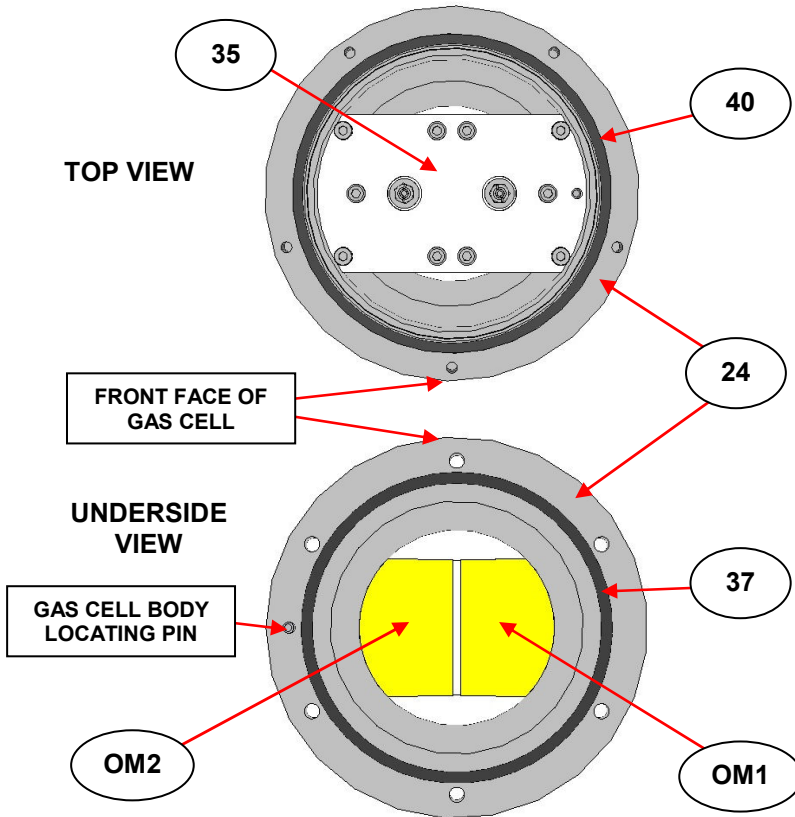

**Fig 28. Objective Mirrors (OM1 and OM2) for the Atmos Gas Cell (Gas Cell Body and Top Cap Assembly Parts Removed)**

**No adhesives** are used for the fitting of the **(FM)**, **(OM1)** and **(OM2)** mirrors providing a fixed pathlength for the Atmos gas cell. Fitting of the mirrors in this way minimizes any risk of sample vapour contamination if an adhesive was to be used from outgassing within the gas cell environment. The design for mounting and support of these mirror components also allows for any thermal expansion effects to keep the gas cell correctly aligned when heated up to their 200°C temperature maximum capability. The gold surfaces on the polished stainless steel mirrors also have an antireflection protective coating and offer typically 98% reflectance performance (at 2000cm<sup>-1</sup>).

## Mirror Cleaning

To clean the mirrors if necessary, the following procedures should be adopted.

### Access to the Field Mirror (FM)

For all variants of the Atmos gas cell, access to the **(FM)** is gained by removal of the metal body assembly **(24)** away from the top section of the optical unit **(1)**. (See **Fig 29.**)

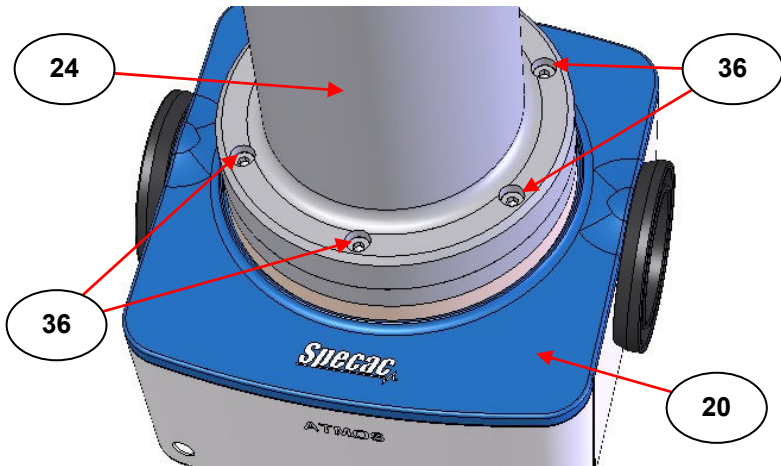

**Fig 29. Atmos Gas Cell Body Fixing Screws to Top of Optical Unit**

**Fig 29.** shows the M4 x 12mm cap head fixing screws (36) that hold the gas cell body (24) to the top section (20), PEEK support ring (26) and (FM) component parts of the optical unit (1). There are six fixings screws (36) for each variant of Atmos gas cell. Using the ball driver tool supplied, undo and remove all six screws (36) and then very carefully lift-up and away, the complete upper gas cell body assembly of parts (24) from the top section of the optical unit (20).

**Note:** *Seen at Fig 27, there is a small alignment hole that orients the gas cell body (24) for a correct fit and positioning of the internal (FM), (OM1) and (OM2) mirror components for operation via a location pin on the gas cell body (24). From removal and refitting of the gas cell body (24) to the top section of the optical unit (20), ensure that the location pin on the underside flange surface of the gas cell body (24) is not damaged to ensure for a correct fit. (See Fig 28.)*

When the upper complete gas cell body components (24) have been separated away, the (FM) can be cleaned carefully using suitable solvents and cleaning materials. Care must be taken when cleaning the gold mirrored surface. Only **very fine lens tissue** should be used to avoid abrasion and consequent possible loss of signal throughput.

From both **Figs 27 and 28.** (underside view), with separation of the gas cell body (24), the lower sealing O-ring (37) can also be accessed for inspection and cleaning if necessary. This sealing O-ring will be in either Kalrez or Viton material as configured from the original build of the supplied Atmos gas cell. Depending upon the integrity of the seal obtained from operation of the Atmos gas cell, the O-ring seal (37) may remain in its lower level recessed groove position as seen for **Fig 27.** or be attached to the underside of the cell body (24) surface when the gas cell body assembly is separated as described and seen for **Fig 28.**

### **Access to the Objective Mirrors (OM1) and (OM2)**

For all variants of the Atmos gas cell, access to the objective mirrors (OM1) and (OM2) is gained by removal of the top cap assembly (that includes the inlet (12) and outlet (13) flow tubes), away from the metal body assembly (24). The exposed mirror frame assembly (35) at the

top of the gas cell can then be removed from the metal body (24) to get to the surfaces of the (OM1) and (OM2) mirrors for cleaning etc.

**Note:** *The metal body assembly (24) does not have to be removed from the top section of the optical unit (20) to gain access to the (FM) if only the (OM1) and (OM2) mirrors need to be inspected and cleaned etc.*

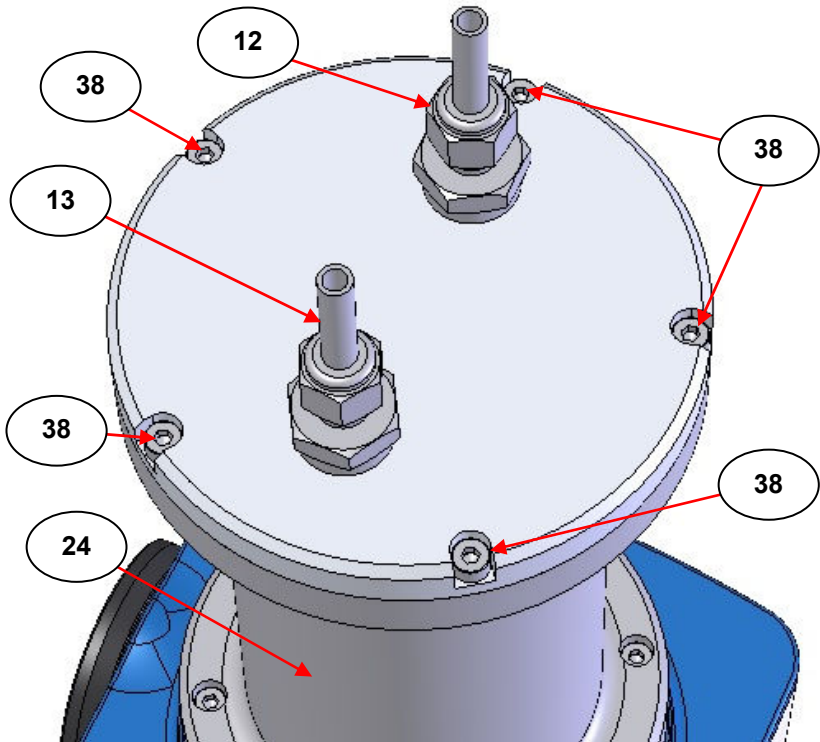

**Fig 30. Atmos Gas Cell Top Cap Assembly Fixing Screws to Gas Cell Body assembly (24)**

**Fig 30.** shows the top of the A5 Atmos gas cell as an example and the five M4 x 10mm cap head fixing screws (38) that are undone to remove the top cap assembly of parts away from the gas cell body (24). (The A2.5 and A5 Atmos gas cells have **five** fixing screws (38) and the A10 and A20 Atmos gas cells have **eight** fixing screws (38) for the top cap assembly of parts.) Use the ball driver tool supplied to undo these screws (38) and carefully lift the top assembly of parts away from the gas cell body (27).

**Note:** *Especial care is needed to ensure the top cap assembly of parts is **pulled up vertically** until the inlet tube (13) passes by and clears the support bridge mirror carriage frame assembly (35).*

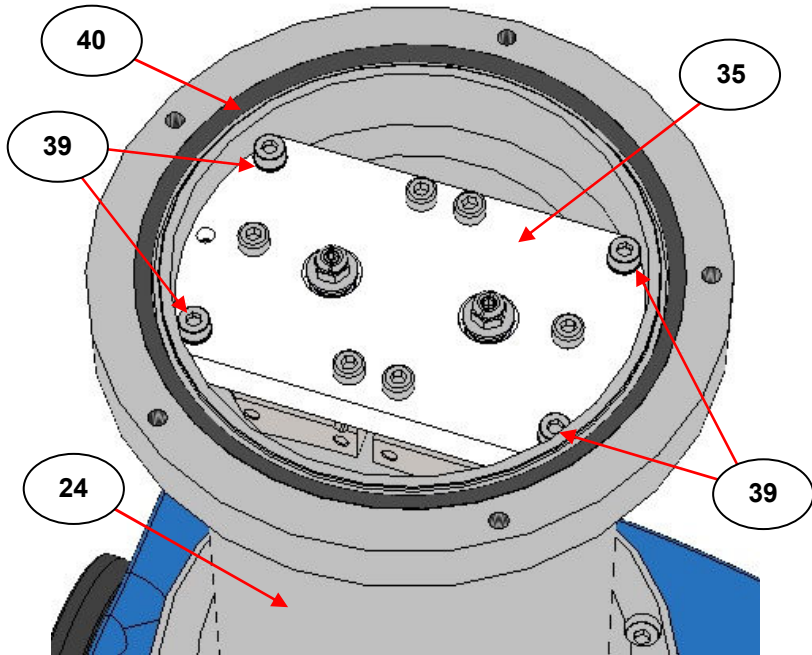

**Fig 31. Atmos Gas Cell Top Cap Assembly Removed from the Gas Cell Body Assembly (24)**

**Fig 31.** shows the objective mirrors (**OM1**) and (**OM2**) support bridge frame assembly (**35**) for the Atmos gas cell when the top cap assembly of parts has been removed. There are four M3 x 12mm cap head fixing screws (**39**) with spring washers that must be undone and removed to lift the entire mirror frame assembly (**35**) up and away from the gas cell body (**24**). Using the ball driver tool provided undo the four screws (**39**) and washers to carefully remove the assembly to gain access to the (**OM1**) and (**OM2**) gold mirror surfaces for their inspection. (See **Fig 32.** – removed mirror frame assembly of parts.)

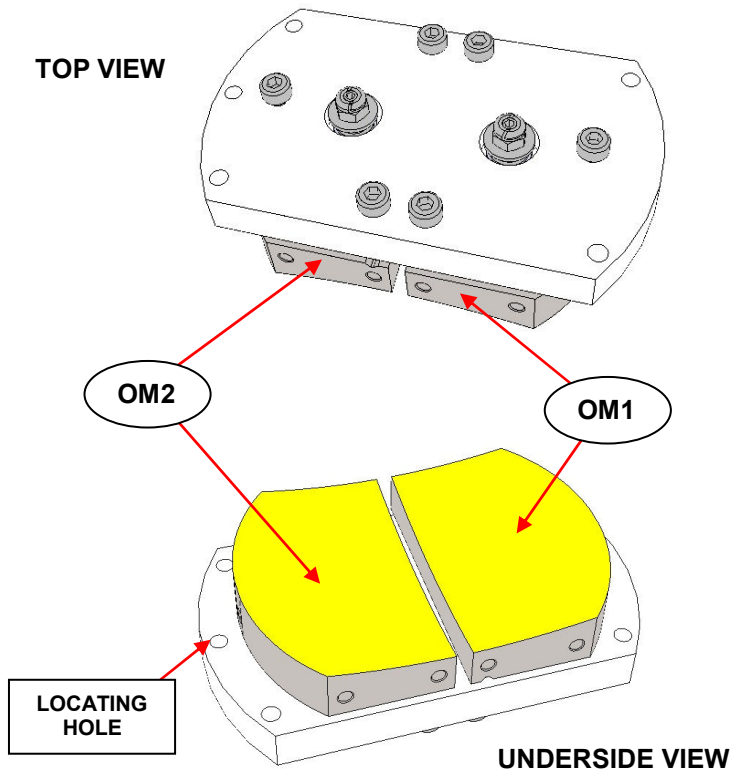

**Fig 32. Atmos Gas Cell - Removed Objective Mirrors Frame Assembly from the Gas Cell Body**

When the objective mirrors frame assembly of components (35) have been removed from the top of the gas cell body (24), the (OM1) and (OM2) mirrors can be cleaned carefully using suitable solvents and cleaning materials. Care must be taken when cleaning the gold mirrored surface. Only **very fine lens tissue** should be used to avoid abrasion and consequent possible loss of signal throughput.

**Note:** *Seen at Fig 32. for the underside view, there is a small locating hole that orients the mirror frame assembly (35) for a correct fit and positioning of the internal (OM1) and (OM2) components. This locating hole fits over its corresponding location pin at the top of the gas cell body (24) prior to refitting of the mirror frame assembly (35) into place using the four screws (39).*

From removal of the top cap assembly of parts, access can also be gained to the top sealing O-ring (40) as seen at Fig 31. As with the sealing O-ring (37) at the base of the gas cell body (24), the top sealing O-ring (32) will be in either Kalrez or Viton material as configured from the original build of the supplied Atmos gas cell. Depending upon the integrity of the seal obtained from operation of the Atmos gas cell, the top sealing O-ring (40) may remain in its lower level recessed groove position in the gas cell body (24) as seen for Fig 31. or be attached to the underside of the removed top cap assembly of parts.

Inspect the top sealing O-ring (40) for its condition and clean or replace as necessary prior to refitting of the top cap assembly of parts into position to the top of the gas cell body using the five fixing screws (38) for A2.5 and A5 gas cells or eight fixing screws (38) for the A10 and A20 gas cells.

**Note:** *Be careful when refitting the top cap assembly of parts such that the inlet tube (12) passes by the mirror frame assembly (35) and is towards the back of the gas cell body (24) when viewed from the front. The fixing screw (38) positions will then be orientated correctly for attachment to the gas cell body (24)*

## Torque Screw Setting Values on Reassembly

There are specific torque screw setting values that are required to apply to the screws (36) and (38) and screws and washers (39) when reassembling the Atmos gas cell after any (FM) and/or (OM1 and OM2) mirror inspections/cleaning.

Screws (36) are used to fix and tighten the Atmos gas cell body (24) to the (FM) plate. (See Fig 29, page 47.) There are 6 screws (36) used for ALL variants of Atmos gas cell.

Screws (38) are used to fix and tighten the top cap assembly to the Atmos gas cell body (24). (See Fig 30, page 49.) There are 5 screws (38) used for the A2.5 and A5 Atmos gas cells and 8 screws (38) used for the A10 and A20 Atmos gas cells.

Screws (39) with spring washers are used to fix and tighten the objective mirrors frame assembly of components (35) to the inside and top of the Atmos gas cell body (24). (See Fig 31, page 50.) There are 4 screws (39) and washers used for ALL variants of Atmos gas cell.

The table below lists the torque setting values in Nm for each screw as identified for ALL Variants of Atmos gas cell.

Gas Cell Size	Screw (36) Torque Nm	Screw (38) Torque Nm	Screw (39) Torque Nm
<b>A2.5</b>	0.7 to 1.0	0.7 to 1.0	0.3 to 0.6
<b>A5</b>	1.0 to 1.3	1.0 to 1.3	0.3 to 0.6
<b>A10</b>	1.3 to 1.5	1.3 to 1.5	0.3 to 0.6
<b>A20</b>	1.3 to 1.5	1.3 to 1.5	0.3 to 0.6

A specific torque wrench device and appropriate adapter fittings as P/N GS24629 is available for purchase to use for tightening these screw fixings to their appropriate torque values. When tightening the screws, do so in sequence, gradually tightening each screw in rotation one at a time from the minimum torque value as stated to the maximum. This ensures an evenness of level fit of the components when being tightened together in this way.

## 10. Cleaning/Care of Atmos Gas Cells

---

After use of the Atmos gas cell it is recommended that the following procedures are adopted to properly care for the accessory.

Flush the cell with dry N<sub>2</sub> (Nitrogen) gas to remove any residual contaminants. If heated gases have been analyzed this will help to remove any condensed vapor on the components of the cell. If the gas cell has been operated at a temperature above ambient/room temperature, then it is recommended to flush through with N<sub>2</sub> gas whilst the gas cell is cooling down to room temperature before storage. N<sub>2</sub> gas can be flowed through if both the inlet (**15**) and outlet (**16**) valve taps (if fitted from P/N GS21621) are open and the valve tap to a flow line from any recommended gas line connectivity has been adopted. (See schematic **Fig 15**, page 29.)

If any parts such as the gas cell body, windows or mirrors require cleaning then suitable solvents may be water, methanol, ethanol and acetone. When cleaning any of the mirrors (in the gas cell and in the optical unit) **always** use a very gentle soft lens tissue moistened with a suitable solvent and dab at the surfaces rather than wiping to minimize the risk of scratching and abrasion to the mirror surfaces.

Place the Atmos gas cell back into its protective carry case or into a dry storage cabinet such as the Specacabinet P/N GS19100.

By following these procedures, the Atmos gas cell will be ready for quick and easy installation the next time it is to be used.

### Notes On Cleaning

When cleaning any removed **window material** being used in the Atmos gas cell, it is **very important to take care** to avoid damage to the window materials. As also mentioned in the Safety Considerations (Section 2, page 5), of the two standard window materials supplied that can be fitted in the gas cell, ZnSe is potentially the most hazardous in terms of risk of toxicity if it contacts with skin.



**Note:** *Always wear gloves to protect yourself and the window material.*

Solvents such as water, methanol, acetone, hexane, chloroform etc are suitable to use for cleaning purposes with CaF<sub>2</sub> and ZnSe window materials. CaF<sub>2</sub> and ZnSe window materials are generally chemically tolerant of a wide range of aqueous based solvents or solutions for cleaning purposes, but only sample solutions that fall within the pH range of pH4 to pH11 are tolerated by the ZnSe window material. Stronger acidic or basic solutions if introduced will irreparably damage any ZnSe windows that are fitted.

**Caution!** *If in doubt that your solvent for cleaning may be damaging to the window material being used with the Atmos gas cell, always try to test a fragment of the window material type, if possible, with the chemical first.*

When wiping away any solid (condensed) residues (if present) on the window surfaces, use a very soft lens tissue moistened with the appropriate solvent to avoid scratches being caused on the surface of the window material. Scratches and blemishes to the window surface will result in poor light throughput for the transmission technique (more risk of light scatter) and an overall degradation in the Atmos gas cell performance.

## Datasheet for Calcium Fluoride (CaF<sub>2</sub>) Material

### General

Known as Calcium Fluoride, Calcium Difluoride, Fluorspar or Irtran 3. When powder is fused together, is used as a transmission window material. Insoluble in water, resists most acids and alkalis. Is soluble in ammonium salts. Its high mechanical strength makes it particularly useful for high pressure work. Brittle material sensitive to mechanical and thermal shock. Does not fog. Molecular formula: CaF<sub>2</sub>. Chemical Abstracts Service (CAS) No: 7789-75-5.

### Physical Data

Appearance: Odourless, white or colourless crystalline solid.  
Melting point: 1360°C.  
Boiling point: 2500°C.  
Solubility in water: 0.0017g/100g at 0°C.  
Hardness: 158 Kg/mm<sup>2</sup>.  
Refractive Index: 1.40 (at 2000cm<sup>-1</sup> - wavenumbers).  
Spectroscopic transmission range: 77,000 \* to 900 cm<sup>-1</sup> (wavenumbers).

### Stability

Stable. Incompatible with acids.

### Toxicology



Harmful if ingested in large amounts, if inhaled, or if in repeated contact with the skin.

### Personal Protection

Always wear safety spectacles and gloves when handling the powder or window material.  
Allow for adequate ventilation.

### Storage

Keep powder or windows stored in a cool, dry container.  
(\* UV Grade material required for this range limit.)

## Datasheet for Zinc Selenide (ZnSe) Material

### General

Toxic and hard yellow coloured crystalline powder when fused together as a solid can be used as a transmission window material or as a crystal material for attenuated total reflectance (ATR) FTIR spectroscopy.

Insoluble in water, but attacked by strong acids and bases. (pH range 4 to 11 tolerant).

Organic solvents have no effect.

Fairly brittle as a window material and sensitive to thermal and mechanical shock.

Molecular formula: ZnSe

Chemical Abstracts Service (CAS) No: 1315-09-9.

### Physical Data

Appearance: Yellow crystals, granular powder or amber coloured window material

Melting point: 1515°C at 1.8 atmospheres. (26.5psi)

Solubility in water: 0g/100g at 0°C.

Hardness: 120 Kg/mm<sup>2</sup>.

Refractive Index: 2.43 (at 2000cm<sup>-1</sup> - wavenumbers).

Spectroscopic transmission range: 20,000 to 500 cm<sup>-1</sup> (wavenumbers).

### Stability

Stable. Reacts with acids to give highly toxic hydrogen selenide. May be air and moisture sensitive. Incompatible with strong acids, strong bases and strong oxidising agents.

### Toxicology



Toxic if small amounts are inhaled or swallowed. In stomach toxic hydrogen selenide (H<sub>2</sub>Se) is liberated. Skin and eye irritant. Danger of cumulative effects from frequent handling without protection.

### Personal Protection

Always wear safety spectacles and gloves when handling the powder or window material. Allow for good ventilation.

### Storage

Keep powder or windows stored in a cool, dry container, with appropriate safety labelling.

## *11. Spares for Atmos Gas Cells*

---

GS24627 ZnSe windows (pair) for Atmos gas cell.

GS24628 CaF<sub>2</sub> windows (pair) for Atmos gas cell.

GS24625 Essential Spares Kit for Atmos A2.5 and A5 gas cells.

GS24626 Essential Spares Kit for Atmos A10 and A20 gas cells.

GS24160 Low or high pressure gauge kit.

GS24161 Inlet and outlet valve tap connections.

GS10707 Purge bellows for optical unit of Atmos gas cells.

GS24629 Torque wrench and adapter fittings for use with Atmos gas cells.

## Part Description for “Bubble” Numbered Items

- (1) Optical unit for Atmos gas cell.
- (2) Pull down tab mechanism of Lever-lock baseplate.
- (3) Mirror assemblies in optical unit (1).
- (4) Optical unit front cover plate.
- (5) Fixing screw for front cover plate (4).
- (6) M3 x 4mm grub screw to lock optical unit mirror assemblies (3).
- (7) M4 x 5mm cap head screw to rotate optical unit mirror surface (3).
- (8) M4 X 12mm grub screw to tilt optical unit mirror surface (3).
- (9) Optical unit purge hole connection port on cover plate (4).
- (10) Purge bellows.
- (11) Circular aperture port on optical unit (1).
- (12) Inlet gas flow tube.
- (13) Outlet gas flow tube.
- (14) Inlet tube on/off valve tap fitting.
- (15) Outlet tube on/off valve tap fitting.
- (16) On/off valve “barbed” hose connection fitting.
- (17) Swagelok locking nut for “barbed” hose connection fitting (16).
- (18) Low and high pressure gauge kit of parts.
- (19) M3 x 10mm cap head screw for top section (20) of optical unit to optical unit box moulding (1).
- (20) Top section of optical unit (1).
- (21) Mirror carriage frame bracket for optical unit mirror assemblies (3).
- (22) M3 x 6mm cap head screw for optical mirror carriage frame bracket (21).
- (23) Window clamping ring for window (27) assembly.
- (24) Atmos gas cell metal body assembly.
- (25) M4 x 25mm cap head fixing screw for top section (20) to Atmos gas cell body (24).
- (26) PEEK heat insulating support ring of Atmos gas cell body (24).
- (27) Window of Atmos gas cell. (CaF<sub>2</sub> or ZnSe).
- (28) Window (27) housing frame assembly.
- (29) M3 x 12mm cap head fixing screw of window housing frame assembly (28).
- (30) M3 x 3mm grub screw for locking of window clamping ring (27).
- (31) PEEK gasket sealing ring of window (27) assembly.
- (32) PTFE gasket sealing ring of window (27) assembly.
- (33) Viton or Kalrez sealing O-ring of window (27) assembly.

## User Manual

- (34) M4 x 8mm cap head screw fixing for PEEK support ring (26) to A2.5 Atmos gas cell body assembly (24).
- (35) Support bridge/mirror frame assembly of objective mirrors (OM1 and OM2).
- (36) M4 x 12mm cap head screw fixing of metal body assembly (24) to the field mirror (FM).
- (37) Lower sealing O-ring of gas cell body assembly (24).
- (38) M4 x 10mm cap head screw fixing of top cap assembly to gas cell body assembly (24).
- (39) M3 x 12mm cap head screw fixing for support bridge/mirror frame assembly (35).
- (40) Top sealing O-ring of gas cell body assembly (24).

# Worldwide Distribution

## **France**

Eurolabo - Paris.  
Tel.01 42 08 01 28  
Fax 01 42 08 13 65  
email: Eurolabo@aol.com

## **Germany**

L.O.T. - Oriel GmbH & Co,  
KG - Darmstadt  
Tel: 06151 88060  
Fax: 06151 880689  
email:info@LOT-Oriel.de  
Website: www.LOT-Oriel.com/de

## **Japan**

Systems Engineering Inc. -Tokyo  
Tel: 03 3946 4993  
Fax: 03 3946 4983  
email:systems-eng@systems-eng.co.jp  
Website: www.systems-eng.co.jp

## **Spain**

Teknokroma S.Coop C. Ltda  
Barcelona  
Tel: 93 674 8800  
Fax: 93 675 2405  
email: comercial@teknokroma.es

## **Switzerland**

Portmann InstrumentsAG  
Biel-Benken  
Tel: 061 726 6555  
Fax: 061 726 6550  
email: info@portmann-instruments.ch  
Website:www.portmann-instruments.ch

## **USA**

SPECAC INC.  
414 Commerce Drive  
Suite 175,  
Fort Washington,  
PA 19034, USA  
Tel: 215 793 4044  
Fax: 215 793 4011

## **United Kingdom**

Specac Ltd. - London  
River House, 97 Cray Avenue,  
Orpington  
Kent BR5 4HE  
Tel: +44 (0) 1689 873134  
Fax: +44 (0) 1689 878527  
Registered No. 1008689 England

# Brilliant Spectroscopy™

*[www.specac.com](http://www.specac.com)*

**SPECAC INC.**

414 Commerce Drive  
Suite 175,  
Fort Washington,  
PA 19034, USA  
Tel: 215 793 4044  
Fax: 215 793 4011

**SPECAC LTD.**

River House, 97 Cray Avenue,  
Orpington  
Kent BR5 4HE  
Tel: +44 (0) 1689 873134  
Fax: +44 (0) 1689 878527  
Registered No. 1008689 England