

DA-LITE®

A brand of  legrand®

Tensioned Advantage® Series

SPECIFICATION DATA



TABLE OF CONTENTS

- 3** Tensioned Advantage[®] (With Closure Door)
Previously Named: Tensioned Advantage Deluxe Electrol

- 5** Tensioned Advantage
Previously Named: Tensioned Advantage Electrol

- 7** Tensioned Advantage with SightLine™

- 9** Tensioned Advantage (Over 14' W with Closure Door)
Previously Named: Tensioned Large Advantage Deluxe Electrol

- 11** Tensioned Advantage (Over 16' W)
Previously Named: Tensioned Large Advantage Electrol

Tensioned Advantage (with Closure Door)

Previously Named: Tensioned Advantage Deluxe Electrol

SUGGESTED SPECIFICATIONS: _____ projection screen(s), _____(H) x _____(W). The Tensioned Advantage® (with Closure Door) screen shall have two motors, one to operate door and one to operate screen. Door motor electrically operated 120 volt (60 Hz) not more than 1.2 amp. Shall have motor mounted inside the roller, to be three wire with ground, quick reversal type, oiled for life, with automatic thermal overload cutout, integral gears, capacitor and an electric brake to prevent coasting. To have pre-set but adjustable limit switches to automatically stop fabric door in the “down” position. The door will lift to the closed position where a micro switch shall cut off the electrical current to the door motor. The roller to be of rigid aluminum. Screen motor is electrically operated 120 volt (60 Hz) not more than 2.4 amp. Shall have motor mounted inside the roller, to be three wire with ground quick reversal type, oiled for life, with automatic thermal overload cutout, integral gears, capacitor and an electric brake to prevent coasting. To have pre-set but adjustable limit switches to automatically stop picture surface in the “up” and “down” positions. The roller to be of rigid metal. Screen fabric to be seamless and mildew resistant with black masking borders standard. Each side of the fabric to have tab guide cable system to maintain even lateral tension and hold surface flat. Custom slat bar with added weight maintains vertical tension on the screen surface. The ends of

the slat to be protected by heavy duty plastic caps enclosing a preset adjustable mechanism for screen tensioning. Case shall be a white powder coated extruded aluminum. Bottom of case to be self-trimming with a built-in flange around the bottom of the case. A section of the bottom of the case shall be an aluminum door equipped with hinges so that it opens and closes automatically with the lowering and raising of the picture surface. The balance of the bottom of the case shall be a second hinged aluminum door with manual opening to provide access. Hinges shall be mounted in a concealed way. Junction box shall be internally integrated into the housing making it possible to install the housing and wire to the building’s electrical system during construction. The junction box shall contain a quick connector that is mounted in the housing for easy plug-in connection to the motorized fabric and roller assembly. The motorized fabric and roller assembly to be installed in the case at the factory or at a later time at the job site. To be complete with integrated low voltage control unit and three position control switch and cover plate. Suitable for use in environmental air space in accordance with section 300-22 (c) of the National Electric Code, and sections 2-128, 12-010 (3) and 12-100 of the Canadian Electrical Code, part 1, CSA C22.1. Screen to be listed by Underwriters’ Laboratories.



HDTV (16:9) Format Dimensions

Viewing Area (H x W)		Nominal Diagonal		Overall Length of Case* For Vinyl Surfaces**		Overall Length of Case* For Parallax® Pure Surface		Approx. Hang. Wt.		Approx. Ship. Wt.	
In.	Cm	In.	Cm	In.	Cm	In.	Cm	Lbs.	Kg	Lbs.	Kg
45" x 80"	114 x 203	92"	234	102.75"	261	101.75"	258	114	51.7	135	61.2
52" x 92"	132 x 234	106"	269	115.25"	293	114.25"	290	127	57.6	156	70.8
54" x 96"	137 x 244	110"	279	119.75"	304	118.75"	302	131	59.4	158	71.7
58" x 104"	147 x 264	119"	302	128.25"	326	127.25"	323	140	63.5	166	75.3
65" x 116"	165 x 295	133"	338	141.25"	359	-	-	153	69.4	182	82.6
78" x 139"	198 x 353	159"	404	166.25"	422	-	-	175	79.4	215	97.5
90" x 160"	229 x 406	184"	467	184.25"	468	-	-	199	90.3	236	107

Wide (16:10) Format Dimensions

Viewing Area (H x W)		Nominal Diagonal		Overall Length of Case* For Vinyl Surfaces**		Overall Length of Case* For Parallax® Pure Surface		Approx. Hang. Wt.		Approx. Ship. Wt.	
In.	Cm	In.	Cm	In.	Cm	In.	Cm	Lbs.	Kg	Lbs.	Kg
50" x 80"	127 x 203	94"	239	103.25"	262	102.25"	260	115	52.2	137	62.1
57.5" x 92"	146 x 234	109"	277	116.25"	295	114.75"	291	128	58.1	148	67.1
60" x 96"	152 x 244	113"	287	120.75"	307	-	-	133	60.3	158	71.7
65" x 104"	165 x 264	123"	312	129.25"	328	-	-	141	64	150	68
69" x 110"	175 x 279	130"	330	135.75"	345	-	-	148	67.1	180	81.6
72.5" x 116"	184 x 295	137"	348	142.25"	361	-	-	155	70.3	180	81.6
87" x 139"	221 x 353	164"	417	163.25"	415	-	-	177	80.3	188	85.3
100" x 160"	254 x 406	189"	480	185.25"	471	-	-	202	91.6	230	104.3

Video (NTSC 4:3) Format Dimensions

Viewing Area (H x W)		Nominal Diagonal		Overall Length of Case* For Vinyl Surfaces**		Approx. Hang. Wt.		Approx. Ship. Wt.	
In.	Cm	In.	Cm	In.	Cm	Lbs.	Kg	Lbs.	Kg
43" x 57"	109 x 145	72"	183	79.25"	201	92	41.7	108	49
50" x 67"	127 x 170	84"	213	90.25"	229	103	46.7	123	55.8
60" x 80"	152 x 203	100"	254	104.25"	265	118	53.5	139	63
69" x 92"	175 x 234	120"	305	118.25"	300	131	59.4	161	73
87" x 116"	221 x 295	150"	381	145.25"	369	155	70.3	180	81.6
108" x 144"	274 x 366	180"	457	170.25"	432	188	85.3	221	100.2
120" x 160"	305 x 406	200"	508	187.25"	476	207	93.9	241	109.3

*Case length does not include flange.

**Vinyl surfaces include all Parallax Stratos, HD Progressive, Da-Mat®, and Da-Tex® surfaces.



PRODUCT NOTES

- All screens except Parallax Pure are standard with 12" black drop at the top. Screens with Parallax Pure surface standard with 2" of black drop at the top. Extra drop may alter case dimensions. Contact Da-Lite for details.
- Overall case length dimensions +/- 1/4" (6mm).
- Detail dimensional drawings, wiring diagrams and installation instructions available upon request.
- Specifications subject to change without notice.
- Custom formats and sizes available upon request.

SURFACE INFORMATION

- All viewing surfaces are standard with black backing except HD Progressive ReView 0.9 and Da-Tex.
- Parallax Pure available in sizes up to 58" x 104" in HDTV format and 57 1/2" x 92" in Wide format.
- HD Progressive 1.1 Perf available in sizes up to 87" x 116" in Video format and 78" x 139" in HDTV format.
- All surfaces will be seamless in the image area.
- All HD Progressive, Da-Mat and Da-Tex surfaces are fire retardant.

WHEN ORDERING, MARK APPROPRIATE SELECTIONS

1. Select size from charts.
2. Select viewing surface (Da-Lite surfaces are GREENGUARD GOLD Certified except Parallax Stratos.):

<input type="checkbox"/> Parallax Pure 0.8	<input type="checkbox"/> HD Progressive 1.3
<input type="checkbox"/> Parallax Stratos 1.0	<input type="checkbox"/> HD Progressive ReView 0.9
<input type="checkbox"/> HD Progressive 1.0	<input type="checkbox"/> Da-Mat
<input type="checkbox"/> HD Progressive 1.0 Perf	<input type="checkbox"/> Da-Tex
<input type="checkbox"/> HD Progressive 1.1 Contrast	
3. Options:

<input type="checkbox"/> 220 Volt (50 Hz) Motor	<input type="checkbox"/> Black Case
---	-------------------------------------
4. Optional Accessories:

<input type="checkbox"/> Screen Controller (TCP/IP, RS232, Dry Contact, and VPI/Trigger)	<input type="checkbox"/> Key Locking Cover Plate for LVC Switch
<input type="checkbox"/> Radio Frequency (BLE) Remote	
<input type="checkbox"/> Infrared Remote	
<input type="checkbox"/> PoE Injector	

SUGGESTED CEILING INSTALLATION

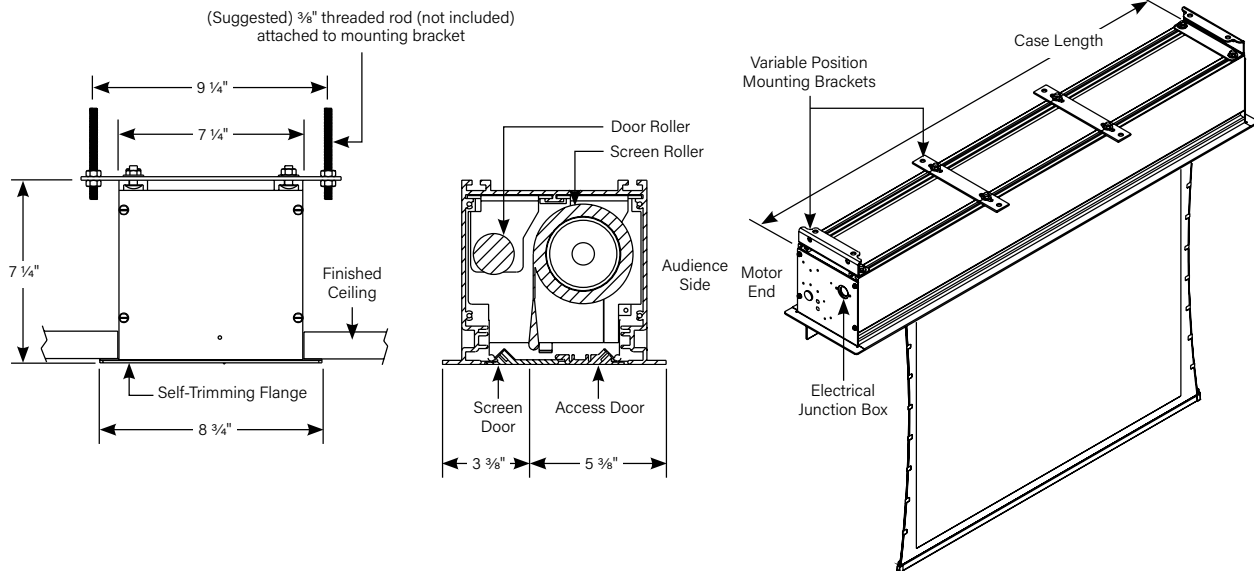

Project Name: _____
 Architect: _____
 Contractor: _____ Phone: _____
 Reseller: _____ Phone: _____

Tensioned Advantage

Previously Named: Tensioned Advantage Electrol

SUGGESTED SPECIFICATIONS: _____ projection screen(s), _____(H) x _____(W), electrically operated 120 volt (60 Hz) not more than 2.4 amp. with a quick connect male plug-in connector on the motor. Shall have specially designed motor mounted inside the roller, to be three wire with ground, quick reversal type, oiled for life, with automatic thermal overload cutout, integral gears, capacitor and an electric brake to prevent coasting. To have preset but adjustable limit switches to automatically stop picture surface in the "up" and "down" positions. Junction box shall be externally integrated into the housing making it possible to install the housing and wire to the building's electrical system during construction. The junction box shall contain a quick connector that is mounted in the housing for easy plug-in connection to the motorized fabric and roller assembly. The motorized fabric and roller assembly to be installed in the case at the factory or at a later time at the job site. The fabric roller to be of rigid steel. Screen fabric to be seamless and mildew resistant with black

masking borders standard. Each side of the fabric to have tab guide cable system to maintain even lateral tension and hold surface flat. Custom slat bar with added weight maintains vertical tension on the screen surface. The ends of the slat to be protected by heavy duty plastic caps enclosing a preset adjustable mechanism for screen tensioning. Top, front and back of case to be made of extruded aluminum powder coated white. End caps to be of heavy gauge steel powder coated white. Bottom of case to have a removable access door. Door to be of extruded aluminum powder coated white. Bottom of case to be self-trimming, with a built-in flange around the bottom of the case. To be complete with integrated low voltage control unit and three position control switch and cover plate. Suitable for use in environmental air space in accordance with section 300-22 (c) of the National Electric Code, and sections 2-128, 12-010 (3) and 12-100 of the Canadian Electrical Code, part 1, CSA C22.1. Screen to be listed by Underwriters' Laboratories.



HDTV (16:9) Format Dimensions

Viewing Area (H x W)		Nominal Diagonal		Overall Length of Case* For Vinyl Surfaces**		Overall Length of Case* For Parallax® Pure Surface		Approx. Hang. Wt.		Approx. Ship. Wt.	
In.	Cm	In.	Cm	In.	Cm	In.	Cm	Lbs.	Kg	Lbs.	Kg
45" x 80"	114 x 203	92"	234	96"	244	95"	241	82	37.2	101	45.8
52" x 92"	132 x 234	106"	269	108.5"	276	107.5"	273	92	41.7	111	50.3
54" x 96"	137 x 244	110"	279	113"	287	112"	284	95	43.1	117	53.1
58" x 104"	147 x 264	119"	302	121.5"	309	120.5"	306	102	46.3	123	55.8
65" x 116"	165 x 295	133"	338	134.5"	342	-	-	112	50.8	136	61.7
78" x 139"	198 x 353	159"	404	159.5"	405	-	-	130	59.0	165	74.8
90" x 160"	229 x 406	184"	467	177.5"	450	-	-	149	67.6	182	82.6
99" x 176"	251 x 447	202"	513	194.5"	494	-	-	164	74.4	426	193.2
108" x 192"	274 x 488	220"	559	211.5"	537	-	-	179	81.2	464	210.5

Wide (16:10) Format Dimensions

Viewing Area (H x W)		Nominal Diagonal		Overall Length of Case* For Vinyl Surfaces**		Overall Length of Case* For Parallax® Pure Surface		Approx. Hang. Wt.		Approx. Ship. Wt.	
In.	Cm	In.	Cm	In.	Cm	In.	Cm	Lbs.	Kg	Lbs.	Kg
50" x 80"	127 x 203	94"	239	96.5"	245	95.5"	243	83	37.6	98	44.5
57.5" x 92"	146 x 234	109"	277	109.5"	278	108"	274	93	42.2	115	52.2
60" x 96"	152 x 244	113"	287	114"	290	-	-	97	44.0	121	54.9
65" x 104"	165 x 264	123"	312	122.5"	311	-	-	104	47.2	125	56.7
69" x 110"	175 x 279	130"	330	129"	328	-	-	109	49.4	130	59
72.5" x 116"	184 x 295	137"	348	135.5"	344	-	-	114	51.7	136	61.7
87" x 139"	221 x 353	164"	417	156.5"	398	-	-	132	59.9	160	72.6
100" x 160"	254 x 406	189"	480	178.5"	453	-	-	152	68.9	179	81.2
110" x 176"	279 x 447	208"	528	196"	498	-	-	167	75.7	428	194.1
120" x 192"	305 x 488	226"	574	213"	541	-	-	183	83.0	467	211.8

Video (NTSC 4:3) Format Dimensions

Viewing Area (H x W)		Nominal Diagonal		Overall Length of Case* For Vinyl Surfaces**		Approx. Hang. Wt.		Approx. Ship. Wt.	
In.	Cm	In.	Cm	In.	Cm	Lbs.	Kg	Lbs.	Kg
43" x 57"	109 x 145	72"	183	72.5"	184	66	29.9	82	37.2
50" x 67"	127 x 170	84"	213	83.5"	212	74	33.6	89	40.4
60" x 80"	152 x 203	100"	254	97.5"	248	85	38.6	102	46.3
69" x 92"	175 x 234	120"	305	111.5"	283	96	43.5	120	54.4
87" x 116"	221 x 295	150"	381	138.5"	352	115	52.2	143	64.9
108" x 144"	274 x 366	180"	457	163.5"	415	141	64.0	168	76.2
120" x 160"	305 x 406	200"	508	180.5"	458	157	71.2	179	81.2

*Case length does not include flange.

**Vinyl surfaces include all Parallax Stratos, HD Progressive, Da-Mat®, and Da-Text® surfaces.

PRODUCT NOTES

- All screens except Parallax Pure standard with 12" black drop at the top. Screens with Parallax Pure surface standard with 2" of black drop at the top. Extra drop may alter case dimensions. Contact Da-Lite for details.
- Overall case length dimensions +/- 1/4" (6mm).
- Electrical junction box extends 2 1/8" (5.4 cm) past case length on left end of case, 1 1/8" (2.9 cm) past ceiling flange.
- Internal junction box available. Will add 3 1/2" (8.9 cm) to overall case length and must be specified at time of order, recommended for drywall installations.
- Junction box on top of case available. Will add 3 1/2" (8.9 cm) to overall case length and 1 7/8" (4.8 cm) to height at left end of case; must be specified at time of order.
- Detail dimensional drawings, wiring diagrams and installation instructions available upon request.
- Specifications subject to change without notice.
- Custom formats and sizes available upon request.
- Silent Motor is standard in sizes up to and including; 133" diagonal HDTV Format, 137" diagonal 16:10 Format and 150" diagonal Video Format. Adding extra drop may change availability of the Silent Motor.

SURFACE INFORMATION

- All viewing surfaces are standard with black backing except HD Progressive ReView 0.9 and Da-Tex.
- Parallax Pure available in sizes up to 58" x 104" in HDTV format and 57 1/2" x 92" in Wide format.
- HD Progressive 1.1 Perf available in sizes up to 87" x 116" in Video format and 78" x 139" in HDTV format.

WHEN ORDERING, MARK APPROPRIATE SELECTIONS

- Select size from charts.
- Select viewing surface (Da-Lite surfaces are GREENGUARD GOLD Certified except Parallax Stratos.):
 - Parallax Pure 0.8
 - Parallax Stratos 1.0
 - HD Progressive 1.0
 - HD Progressive 1.0 Perf
 - HD Progressive 1.1 Contrast
 - HD Progressive 1.3
 - HD Progressive ReView 0.9
 - Da-Mat
 - Da-Tex
- Options:
 - Internal Junction Box (see product notes)
 - Junction Box on Top of Case (see product notes)
 - 220 Volt (50 Hz) Motor
 - Black Case
- Optional Accessories:
 - Screen Controller (TCP/IP, RS232, Dry Contact, and VPI/Trigger)
 - Radio Frequency (BLE) Remote
 - Infrared Remote
 - PoE Injector
 - Key Locking Cover Plate for LVC Switch

SUGGESTED METHODS OF INSTALLATION:

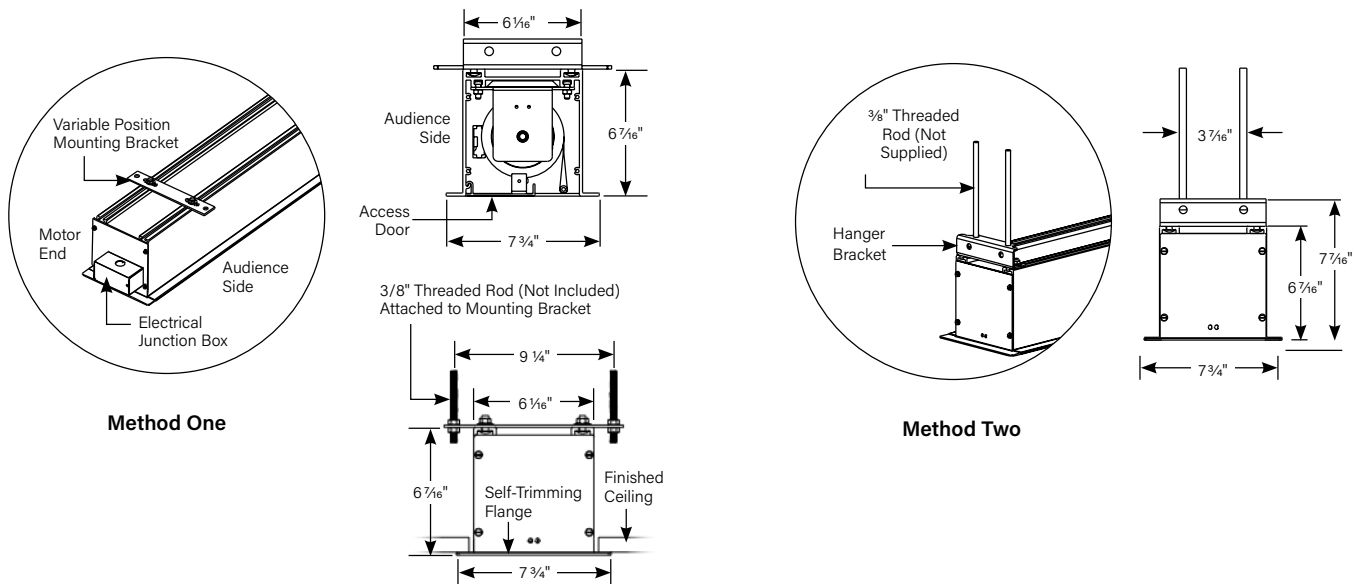

Project Name: _____
 Architect: _____
 Contractor: _____ Phone: _____
 Reseller: _____ Phone: _____

Tensioned Advantage with SightLine

SUGGESTED SPECIFICATIONS: _____projection screen(s), _____(H) x _____(W), electrically operated 120 volt (60 Hz) not more than 2.4 amp. with a quick connect male plug-in connector on the motor. Shall have specially designed motor mounted inside the roller, to be three wire with ground, quick reversal type, oiled for life, with automatic thermal overload cutout, integral gears, capacitor and an electric brake to prevent coasting. To have preset but adjustable limit switches to automatically stop picture surface in the "up" and "down" positions. Junction box shall be externally integrated into the housing making it possible to install the housing and wire to the building's electrical system during construction. The junction box shall contain a quick connector that is mounted in the housing for easy plug-in connection to the motorized fabric and roller assembly. Roller designed to drop material from case on 1mm 7/19 galvanized aircraft cable (70" maximum). The motorized fabric and roller assembly to be installed in the case at the factory or at a later time at the job site. The fabric roller to be of rigid steel. Screen fabric to be seamless and mildew resistant with black

masking borders standard. Each side of the fabric to have tab guide cable system to maintain even lateral tension and hold surface flat. Custom slat bar with added weight maintains vertical tension on the screen surface. The ends of the slat to be protected by heavy duty plastic caps enclosing a preset adjustable mechanism for screen tensioning. Top, front and back of case to be made of extruded aluminum powder coated white. End caps to be of heavy gauge steel powder coated white. Bottom of case to have a removable access door. Door to be of extruded aluminum powder coated white. Bottom of case to be self-trimming, with a built-in flange around the bottom of the case. To be complete with integrated low voltage control unit and three position control switch and cover plate. Suitable for use in environmental air space in accordance with section 300-22 (c) of the National Electric Code, and sections 2-128, 12-010 (3) and 12-100 of the Canadian Electrical Code, part 1, CSA C22.1. Screen to be listed by Underwriters' Laboratories.



HDTV (16:9) Format Dimensions

Viewing Area (H x W)		Nominal Diagonal		Overall Length of Case*		# of Cables	Approx. Hang. Wt.		Approx. Ship. Wt.	
In.	Cm	In.	Cm	In.	Cm		Lbs.	Kg	Lbs.	Kg
45" x 80"	114 x 203	92"	234	94.5"	240	3	91	41.3	125	56.7
52" x 92"	132 x 234	106"	269	107"	272	3	100	45.4	141	64
54" x 96"	137 x 244	110"	279	111.5"	283	3	105	47.6	147	66.7
58" x 104"	147 x 264	119"	302	119.5"	304	3	111	50.3	158	71.7
65" x 116"	165 x 295	133"	338	132.5"	337	4	122	55.3	175	79.4
78" x 139"	198 x 353	159"	404	157"	399	4	149	67.6	207	93.9
87" x 153.75"	221 x 391	177"	450	169.75"	431	4	164	74.4	220	99.8

Wide (16:10) Format Dimensions

Viewing Area (H x W)		Nominal Diagonal		Overall Length of Case*		# of Cables	Approx. Hang. Wt.		Approx. Ship. Wt.	
In.	Cm	In.	Cm	In.	Cm		Lbs.	Kg	Lbs.	Kg
50" x 80"	127 x 203	94"	239	95"	241	3	88	39.9	125	56.7
57.5" x 92"	146 x 234	109"	277	107.5"	273	3	104	47.2	142	64.4
60" x 96"	152 x 244	113"	287	112"	284	3	104	47.2	148	67.1
65" x 104"	165 x 264	123"	312	120.5"	306	4	111	50.3	159	72.1
69" x 110"	175 x 279	130"	330	127"	323	4	117	53.1	168	76.2
72.5" x 116"	184 x 295	137"	348	133.5"	339	4	122	55.3	176	79.8
87" x 139"	221 x 353	164"	417	158.5"	403	4	149	67.6	215	97.5
96" x 153.75"	244 x 391	182"	462	170.25"	432	4	164	74.4	225	102.1

Ultrawide (21:9) Format Dimensions

Viewing Area (H x W)		Nominal Diagonal		Overall Length of Case*		# of Cables	Approx. Hang. Wt.		Approx. Ship. Wt.	
In.	Cm	In.	Cm	In.	Cm		Lbs.	Kg	Lbs.	Kg
40.5" x 96"	103 x 244	104"	264	110.5"	281	3	99	44.9	142	64.4
50.75" x 120"	129 x 305	130"	330	134.5"	342	4	131	59.4	187	84.8
60.75" x 144"	154 x 366	156"	396	160.5"	408	4	145	65.8	207	93.9
64.75" x 153.75"	164 x 391	167"	424	167.25"	425	4	155	70.3	221	100.2
69" x 110"	175 x 279	130"	330	127"	323	4	117	53.1	130	59.0
72.5" x 116"	184 x 295	137"	348	133.5"	339	4	122	55.3	136	61.7
87" x 139"	221 x 353	164"	417	158.5"	403	4	149	67.6	165	74.8
96" x 153.75"	244 x 391	182"	462	170.25"	432	4	164	74.4	182	82.6

*Case length does not include flange.

PRODUCT NOTES

- All screens standard with 70" of fully adjustable cable drop. Drop set to 24" at the factory and adjusted to desired distance during installation.
- Screens with a case length of 120" or under drop from 3 cables. Screens with a case length over 120" drop from 4 cables.
- Overall case length dimensions +/- 1/4" (6mm).
- Electrical junction box extends 2 1/8" (5.4 cm) past case length on left end of case, 1 1/8" (2.9 cm) past ceiling flange.
- Internal junction box available. Will add 3 1/2" (8.9 cm) to overall case length and must be specified at time of order, recommended for drywall installations.
- Junction box on top of case available. Will add 3 1/2" (8.9 cm) to overall case length and 1 7/8" (4.8 cm) to height at left end of case; must be specified at time of order.
- Detail dimensional drawings, wiring diagrams and installation instructions available upon request.
- Specifications subject to change without notice.

- Custom formats and sizes available upon request.
- Silent Motor is standard in sizes up to and including; 119" diagonal HDTV Format, 130" diagonal 16:10 Format and 104" diagonal Ultrawide Format. Adding extra drop may change availability of the Silent Motor.

SURFACE INFORMATION

- All viewing surfaces are standard with black backing.
- HD Progressive 1.1 Perf available in sizes that do not exceed 94" in viewable height.
- All surfaces will be seamless in the image area.
- All HD Progressive and Da-Mat surfaces are fire retardant.

WHEN ORDERING, MARK APPROPRIATE SELECTIONS

- Select size from charts.
- Select viewing surface (Da-Lite surfaces are GREENGUARD GOLD Certified except Parallax Stratos.):

- | | |
|--|--|
| <input type="checkbox"/> Parallax Stratos 1.0 | <input type="checkbox"/> HD Progressive 1.1 Contrast |
| <input type="checkbox"/> HD Progressive 1.0 | <input type="checkbox"/> HD Progressive 1.3 |
| <input type="checkbox"/> HD Progressive 1.0 Perf | <input type="checkbox"/> Da-Mat |

3. Options:

- | | |
|---|---|
| <input type="checkbox"/> Internal Junction Box
(see product notes) | <input type="checkbox"/> 10' Cable Drop |
| <input type="checkbox"/> Junction Box on Top of Case
(see product notes) | <input type="checkbox"/> 220 Volt (50 Hz) Motor |
| | <input type="checkbox"/> Black Case |

4. Optional Accessories:

- | |
|---|
| <input type="checkbox"/> Screen Controller
(TCP/IP, RS232, Dry Contact, and VPI/Trigger) |
| <input type="checkbox"/> Radio Frequency (BLE) Remote |
| <input type="checkbox"/> Infrared Remote |
| <input type="checkbox"/> PoE Injector |
| <input type="checkbox"/> Key Locking Cover Plate for LVC Switch |

PRODUCT VIEWS & SUGGESTED CEILING INSTALLATION

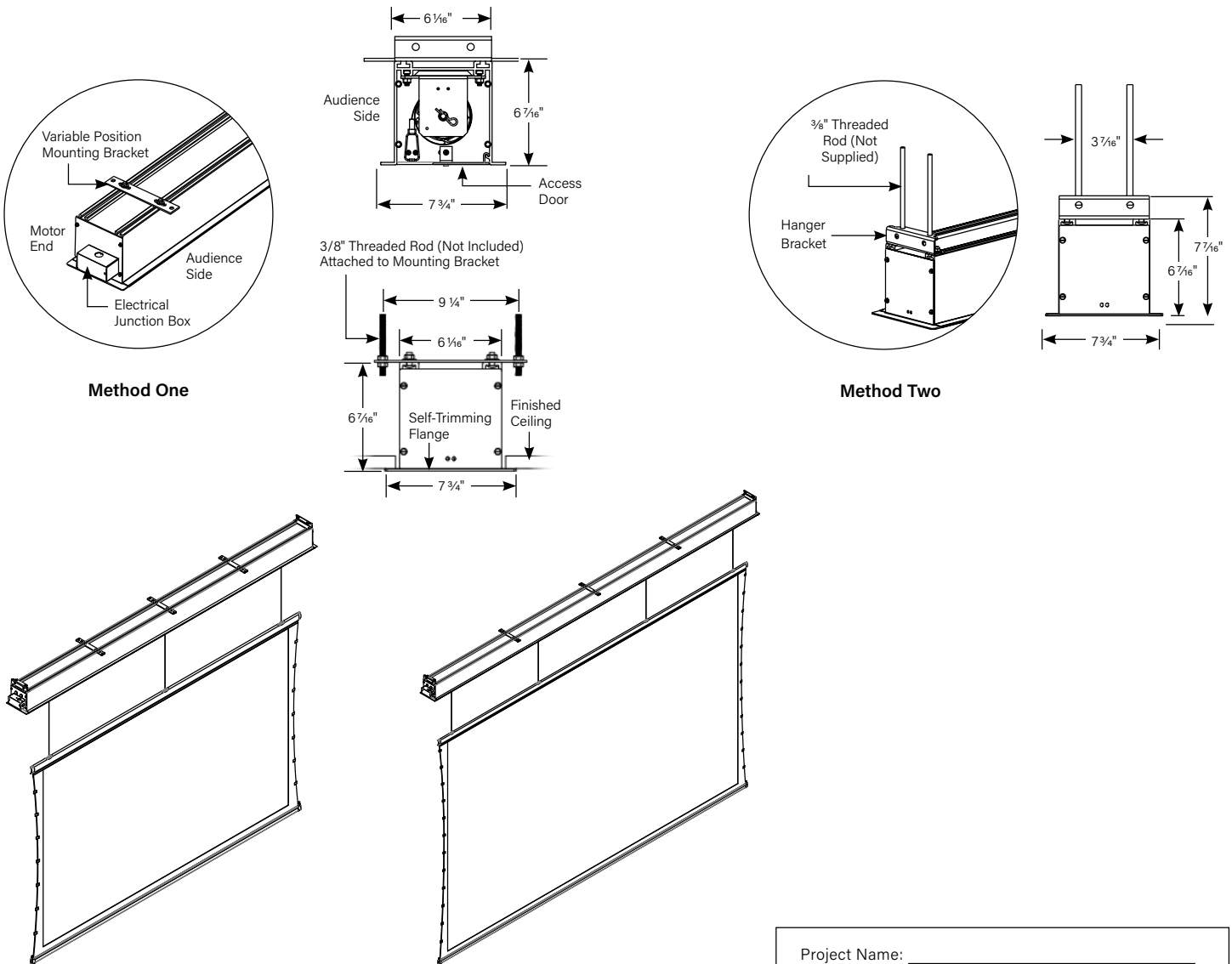

Project Name: _____

Architect: _____

Contractor: _____

Phone: _____

Reseller: _____

Phone: _____

Tensioned Advantage® (over 14' W with Closure Door)

Previously Named: Tensioned Large Advantage Deluxe Electrol

SUGGESTED SPECIFICATIONS: _____ projection screen(s), _____(H) x _____(W). The Tensioned Advantage® (over 14' W with Closure Door) screen shall have two motors, one to operate door and one to operate screen. Door motor electrically operated 120 volt (60 Hz) not more than 1.2 amp. Shall have motor mounted inside the roller, to be three wire with ground, quick reversal type, oiled for life, with automatic thermal overload cutout, integral gears, capacitor and an electric brake to prevent coasting. To have pre-set but adjustable limit switches to automatically stop fabric door in the "down" position. The door will lift to the closed position where a micro switch shall cut off the electrical current to the door motor. The roller to be of 1.6" diameter aluminum. Screen motor is electrically operated 120 volt (60 Hz) not more than 2.4 amp. Shall have motor mounted inside the roller, to be three wire with ground quick reversal type, oiled for life, with automatic thermal overload cutout, integral gears, capacitor and an electric brake to prevent coasting. To have pre-set but adjustable limit switches to automatically stop picture surface in the "up" and "down" positions. The fabric roller to be of 4½" diameter (5¾" if 270" diagonal, 275" diagonal, or 298" diagonal) metal. Screen fabric to be seamless and mildew resistant with black masking borders standard. Each side of the fabric to have tab guide cable system to maintain even lateral tension and hold surface flat. Custom

slat bar with added weight maintains vertical tension on the screen surface. The ends of the slat to be protected by heavy duty plastic caps enclosing a preset adjustable mechanism for screen tensioning. Case shall be a white powder coated extruded aluminum. Bottom of case to be self-trimming with a built-in flange around the bottom of the case. A section of the bottom of the case shall be a retractable aluminum door that opens and closes automatically with the lowering and raising of the picture surface. The balance of the bottom of the case shall be a second hinged aluminum door with manual opening to provide access. Hinges shall be mounted in a concealed way. Junction box shall be internally integrated into the housing making it possible to install the housing and wire to the building's electrical system during construction. The junction box shall contain a quick connector that is mounted in the housing for easy plug-in connection to the motorized fabric and roller assembly. The motorized fabric and roller assembly to be installed in the case at the factory or at a later time at the job site. To be complete with integrated low voltage control unit and three position control switch with cover plate. Suitable for use in environmental air space in accordance with section 300-22 (c) of the National Electric Code, and sections 2-128, 12-010 (3) and 12-100 of the Canadian Electrical Code, part 1, CSA C22.1. Screen to be listed by Underwriters' Laboratories.



HDTV (16:9) Format Dimensions

Viewing Area (H x W)		Nominal Diagonal		Overall Length of Case*		Approx. Hang. Wt.		Approx. Ship. Wt.	
In.	Cm	In.	Cm	In.	Cm	Lbs.	Kg	Lbs.	Kg
108" x 192"	274 x 488	220"	559	220.75"	561	377	171.0	688	312.1
121" x 216"	307 x 549	247"	627	246.75"	627	418	189.6	764	346.5
135" x 240"	343 x 610	275"	699	272.75"	693	460	208.7	841	381.5
146" x 260"	371 x 660	298"	757	294.25"	747	495	224.5	870	394.6

Wide (16:10) Format Dimensions

Viewing Area (H x W)		Nominal Diagonal		Overall Length of Case*		Approx. Hang. Wt.		Approx. Ship. Wt.	
In.	Cm	In.	Cm	In.	Cm	Lbs.	Kg	Lbs.	Kg
110" x 176"	279 x 447	208"	528	205.5"	522	354	160.6	691	313.4
120" x 192"	305 x 488	226"	574	222.25"	565	382	173.3	729	330.7
135" x 216"	342 x 549	255"	648	248.25"	631	423	191.9	764	346.5
150" x 240"	381 x 610	283"	719	273.75"	695	467	211.8	841	381.5

Video (NTSC 4:3) Format Dimensions

Viewing Area (H x W)		Nominal Diagonal		Overall Length of Case*		Approx. Hang. Wt.		Approx. Ship. Wt.	
In.	Cm	In.	Cm	In.	Cm	Lbs.	Kg	Lbs.	Kg
126" x 168"	320 x 427	210"	533	199.25"	506	348	157.9	628	284.9
132" x 176"	335 x 447	220"	559	208.25"	529	362	164.2	655	297.1
144" x 192"	366 x 488	240"	610	225.75"	573	391	177.4	708	321.1
162" x 216"	411 x 549	270"	686	251.25"	638	435	197.3	781	354.3

*Case length does not include flange.

PRODUCT NOTES

- All viewing surfaces will be seamless.
- All viewing surfaces are standard with black backing except HD Progressive ReView 0.9 and Da-Tex®.
- All screens standard with 12" black drop at the top except the 150"H x 240"W (283" diagonal) and 162"H x 216"W (270" diagonal), which have 2".
- Extra drop may alter case dimensions. Contact Da-Lite for details.
- Overall case length dimensions +/- ¼" (6mm).
- Detail dimensional drawings, wiring diagrams and installation instructions available upon request.
- Specifications subject to change without notice.
- Custom formats and sizes available upon request.
- All HD Progressive, Da-Mat and Da-Tex surfaces are fire retardant.



WHEN ORDERING, MARK APPROPRIATE SELECTIONS

1. Select size from charts.
2. Select viewing surface (Da-Lite surfaces are GREENGUARD GOLD Certified except Parallax Stratos):
 - Parallax® Stratos 1.0 Da-Mat
 - HD Progressive 1.0 Da-TeX
 - HD Progressive 1.1 Contrast
 - HD Progressive 1.3
 - HD Progressive ReView 0.9

3. Options:
 - 220 Volt (50 Hz) Motor Black Case
4. Optional Accessories:
 - Screen Controller (TCP/IP, RS232, Dry Contact, and VPI/Trigger) Key Locking Cover Plate for LVC Switch
 - Radio Frequency (BLE) Remote
 - Infrared Remote
 - PoE Injector

PRODUCT VIEWS

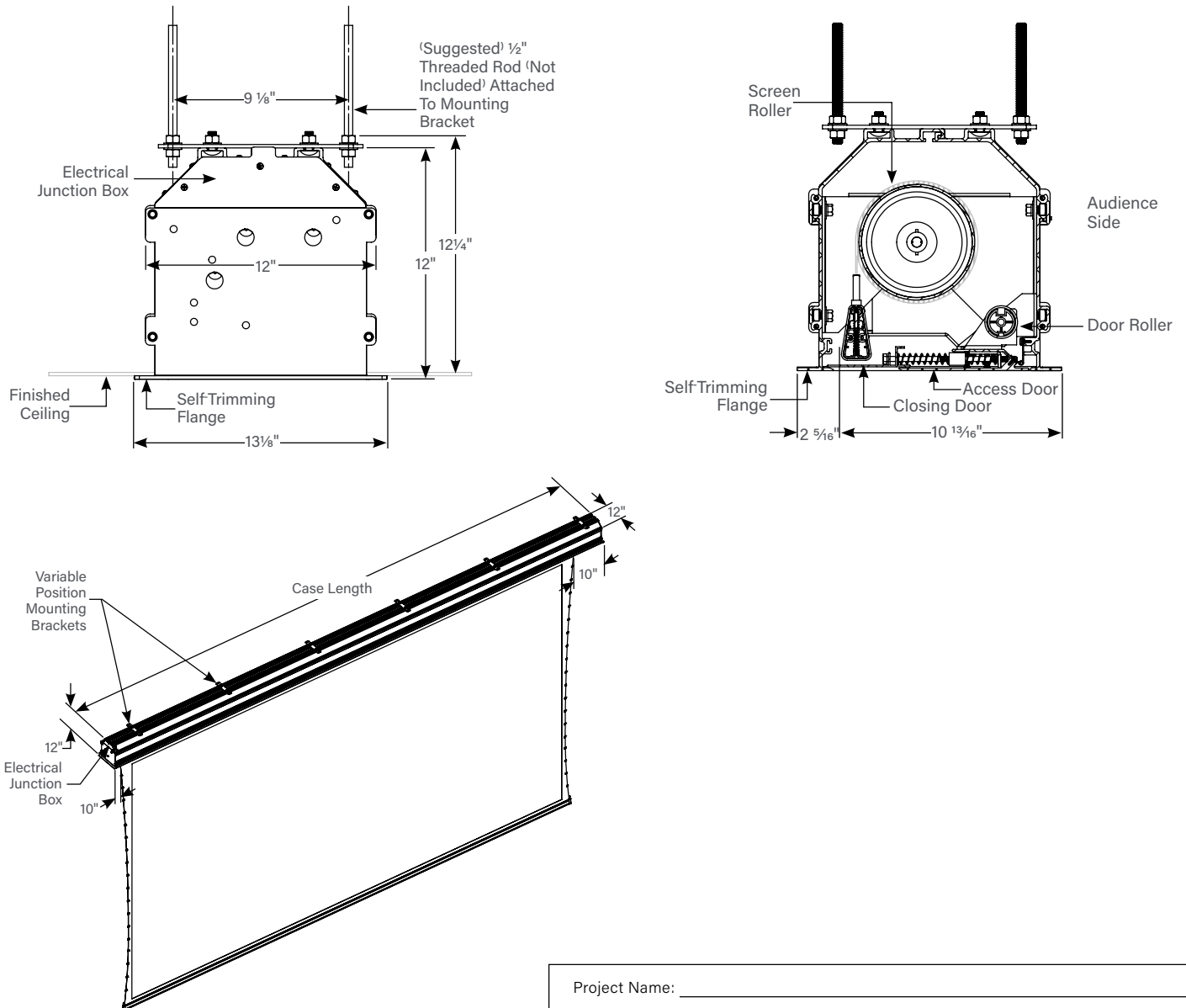

Project Name: _____	
Architect: _____	Phone: _____
Contractor: _____	Phone: _____
Supervisor: _____	Phone: _____
Supplier: _____	Date: _____
Revised: _____	

Tensioned Advantage[®] (over 16' W)

Previously Named: Tensioned Large Advantage Electrol

SUGGESTED SPECIFICATIONS: _____ projection screen(s), _____(H) x _____(W), electrically operated 120 volt (60 Hz) not more than 2.4 amp. with a quick connect male plug-in connector on the motor. Shall have specially designed motor mounted inside the roller, to be three wire with ground, quick reversal type, oiled for life, with automatic thermal overload cutout, integral gears, capacitor and an electric brake to prevent coasting. To have preset but adjustable limit switches to automatically stop picture surface in the "up" and "down" positions. Junction box shall be internally integrated into the housing making it possible to install the housing and wire to the building's electrical system during construction. The junction box shall contain a quick connector that is mounted in the housing for easy plug-in connection to the motorized fabric and roller assembly. The motorized fabric and roller assembly to be installed in the case at the factory or at a later time at the job site. The fabric roller to be of 4½" diameter (5¾" if 270" diagonal, 275" diagonal, or 298" diagonal) metal. Screen

fabric to be seamless and mildew resistant with black masking borders standard. Each side of the fabric to have tab guide cable system to maintain even lateral tension and hold surface flat. Custom slat bar with added weight maintains vertical tension on the screen surface. The ends of the slat to be protected by heavy duty plastic caps enclosing a preset adjustable mechanism for screen tensioning. Case to be made of extruded aluminum powder coated white. End caps to be of heavy gauge steel powder coated white. Bottom of case to have a removable access door. Door to be of extruded aluminum powder coated white. Bottom of case to be self-trimming, with a built-in flange around the bottom of the case. To be complete with integrated low voltage control unit and three position control switch with cover plate. Suitable for use in environmental air space in accordance with section 300-22 (c) of the National Electric Code, and sections 2-128, 12-010 (3) and 12-100 of the Canadian Electrical Code, part 1, CSA C22.1. Screen to be listed by Underwriters' Laboratories.



HDTV (16:9) Format Dimensions

Viewing Area (H x W)		Nominal Diagonal		Overall Length of Case*		Approx. Hang. Wt.		Approx. Ship. Wt.	
In.	Cm	In.	Cm	In.	Cm	Lbs.	Kg	Lbs.	Kg
121" x 216"	307 x 549	247"	627	246.75"	627	366	166.0	727	329.8
135" x 240"	343 x 610	275"	699	272.75"	693	405	183.7	803	364.2
146" x 260"	371 x 660	298"	757	294.25"	747	438	198.7	847	384.2

Wide (16:10) Format Dimensions

Viewing Area (H x W)		Nominal Diagonal		Overall Length of Case*		Approx. Hang. Wt.		Approx. Ship. Wt.	
In.	Cm	In.	Cm	In.	Cm	Lbs.	Kg	Lbs.	Kg
135" x 216"	342 x 549	255"	648	248.25"	631	372	168.7	727	329.8
150" x 240"	381 x 610	283"	719	273.75"	695	412	186.9	803	364.2

Video (NTSC 4:3) Format Dimensions

Viewing Area (H x W)		Nominal Diagonal		Overall Length of Case*		Approx. Hang. Wt.		Approx. Ship. Wt.	
In.	Cm	In.	Cm	In.	Cm	Lbs.	Kg	Lbs.	Kg
162" x 216"	411 x 549	270"	686	251.25"	638	383	173.7	744	337.5

*Case length does not include flange.

PRODUCT NOTES

- All surfaces will be seamless.
- All viewing surfaces are standard with black backing except HD Progressive ReView 0.9 and Da-Tex[®].
- All screens standard with 12" black drop at the top except the 150"H x 240"W (283" diagonal) and 162"H x 216"W (270" diagonal), which have 2".
- Extra drop may alter case dimensions. Contact Da-Lite for details.
- Overall case length dimensions +/- ¼".
- Detail dimensional drawings, wiring diagrams and installation instructions available upon request.
- Specifications subject to change without notice.
- Custom formats and sizes available upon request.
- All HD Progressive, Da-Mat and Da-Tex surfaces are fire retardant.

WHEN ORDERING, MARK APPROPRIATE SELECTIONS

- Select size from charts.
- Select viewing surface (Da-Lite surfaces are GREENGUARD GOLD Certified except Parallax Stratos.):

<input type="checkbox"/> Parallax Stratos 1.0	<input type="checkbox"/> HD Progressive ReView 0.9
<input type="checkbox"/> HD Progressive 1.0	<input type="checkbox"/> Da-Mat
<input type="checkbox"/> HD Progressive 1.1 Contrast	<input type="checkbox"/> Da-Tex
<input type="checkbox"/> HD Progressive 1.3	
- Options:

<input type="checkbox"/> 220 Volt (50 Hz) Motor	<input type="checkbox"/> Black Case
---	-------------------------------------
- Optional Accessories:

<input type="checkbox"/> Screen Controller (TCP/IP, RS232, Dry Contact, and VPI/Trigger)	<input type="checkbox"/> Key Locking Cover Plate for LVC Switch
<input type="checkbox"/> Radio Frequency (BLE) Remote	
<input type="checkbox"/> Infrared Remote	
<input type="checkbox"/> PoE Injector	



PRODUCT VIEWS

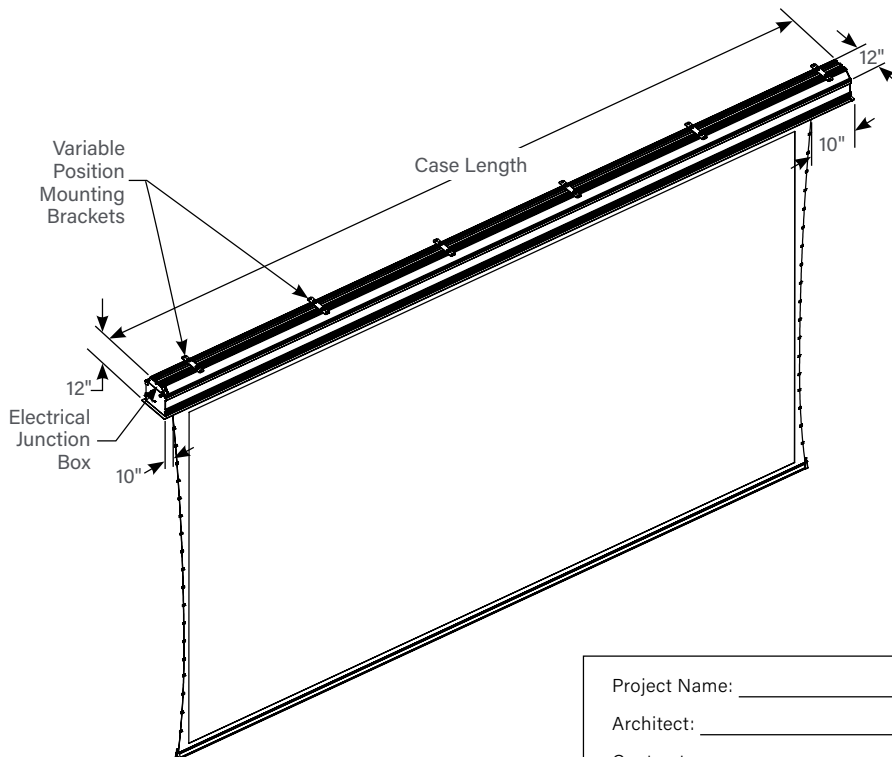
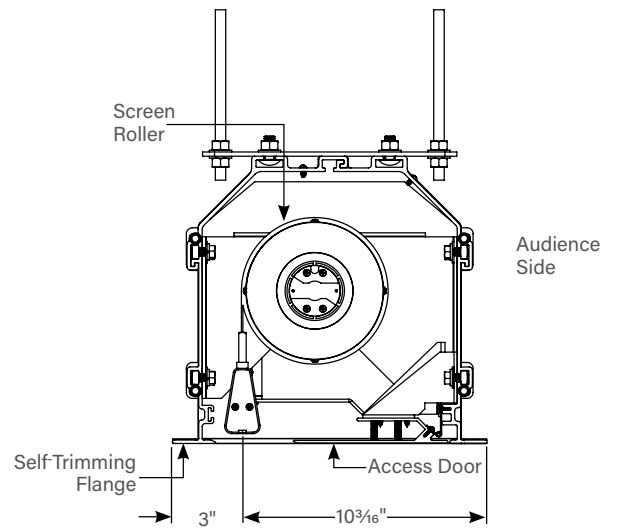
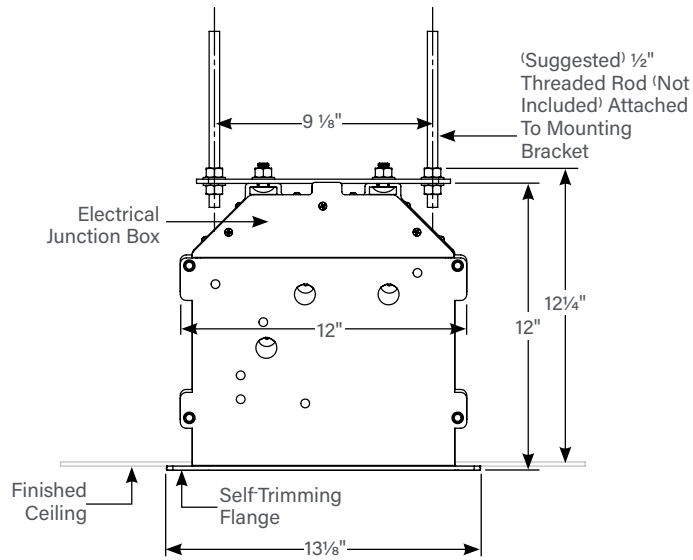

Project Name:	_____
Architect:	_____ Phone: _____
Contractor:	_____ Phone: _____
Supervisor:	_____ Phone: _____
Supplier:	_____ Date: _____
Revised:	_____

LEGRAND | AV COMMERCIAL BRANDS

C2G | Chief | Da-Lite | Luxul | Middle Atlantic | Vaddio | Wiremold

FOR YOUR IMAGE | legrandav.com

USA 866.977.3901 av.da-lite.support@legrand.com CANADA 877.345.4329 av.da-lite.support@legrand.com

EMEA +31 495 580 840 av.emea.sales@legrand.com APAC +852 2145 4099 av.asia.sales@legrand.com

©2026 Legrand AV Inc. 190338 Rev F 4/26 Da-Lite is a registered trademark of Legrand AV Inc. All other brand names or marks are used for identification purposes and are trademarks of their respective owners. All patents are protected under existing designations. Other patents pending.