

MULTISTAGE HORIZONTAL PUMPS

LEADER
PUMPS



INOXPLUS



ECOPLUS



GENERAL DATA

Applications

Self-priming multi-stage pumps ideal for supplying water for domestic and irrigation applications. Low noise and high pressure performance. Available with 3, 4 and 5 impellers.

Construction features of the pump

- Anti-corrosive and rust-proof materials
- Motor with thermic overload protection
- Double sealing system between motor and hydraulic part
- High resistance to frost and icing
- Supplied with power cable with plug, switch and self-sealing fitting

ECOPLUS

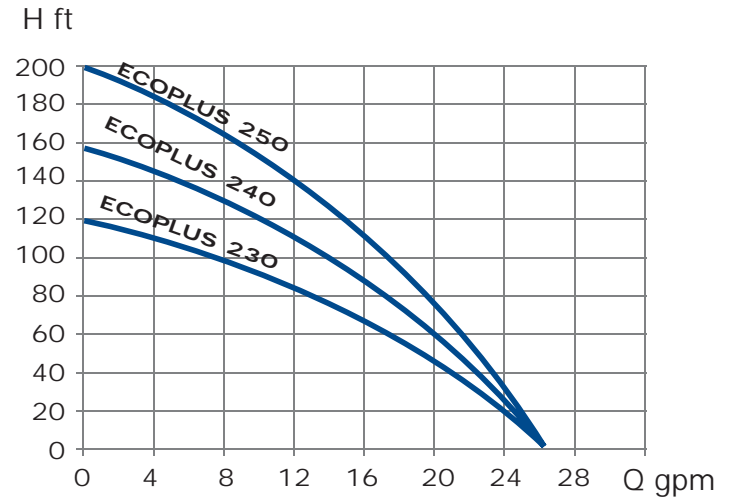
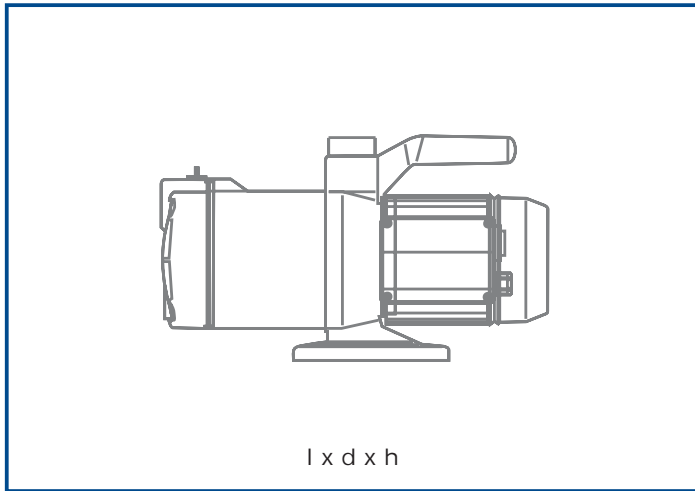

Model	P1 W-HP	H max Ft	Q max Gpm	H max Ft	impellers	1"	Max Psi
230	800-1/2	118	27	26	3	1"	52
240	1000-3/4	157	27	26	4	1"	69
250	1250-1	197	27	26	5	1"	86

Model	Inch	lb	
230	14.4x8.7x9.8	19	35
240	16.3x8.7x9.8	23	35
250	16.5x8.7x9.8	27	35

INOXPLUS

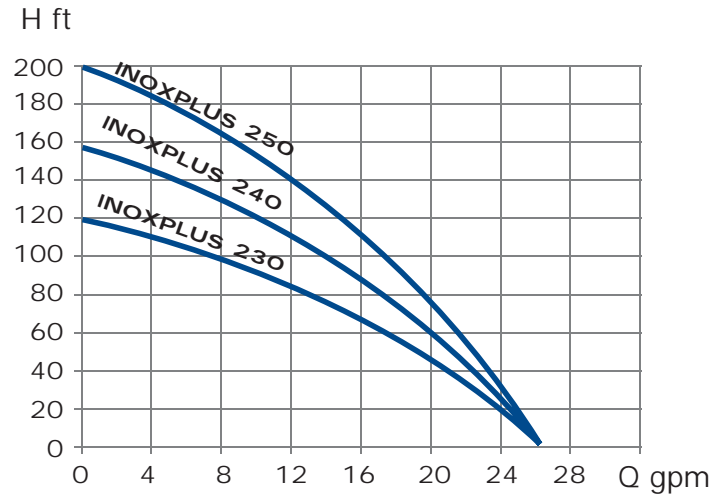
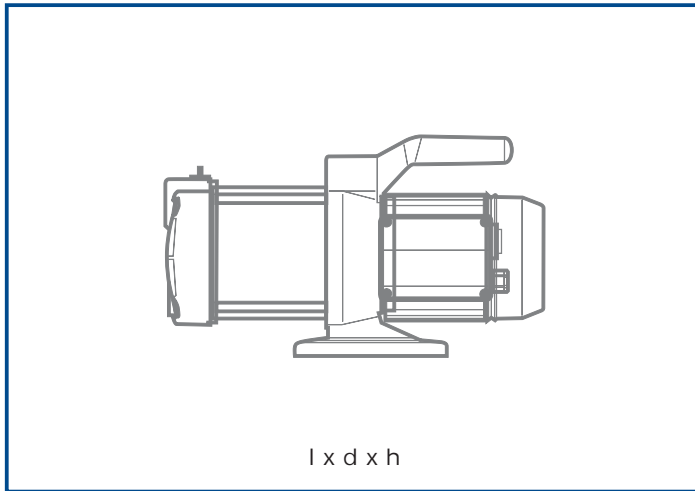

Model	P1 W-HP	H max Ft	Q max Gpm	H max Ft	impellers	1"	Max Psi
230	800-1/2	118	27	26	3	1"	52
240	1000-3/4	157	27	26	4	1"	69
250	1250-1	197	27	26	5	1"	86

Model	Inch	lb	35
230	14.6x8.7x9.8	18	35
240	15.4x8.7x9.8	22	35
250	16.5x8.7x9.8	26	35