

Technical specifications

Losses

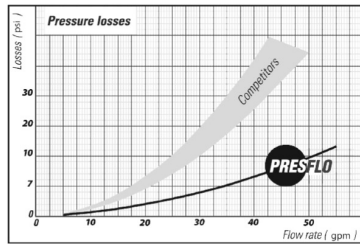

Working area

To set the running pressure (P_m) and the max. motor current (I_{max}), see **Configuration** paragraph.

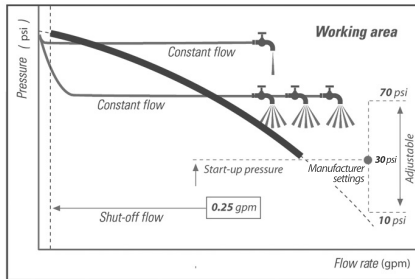

Water accumulator pressure.

Should be inflated to a value 3 + 7 psi lower than the running pressure.

Manufacturer settings 24 psi



Operating conditions

A. Compatible/non compatible fluids

PRESFLO® is suitable for use with clean water and chemically non-aggressive liquids. If the fluid contains impurities, a filter should be fitted upstream.

B. Environmental conditions

PRESFLO® should not be used where there is the risk of an explosion. The temperature of the location should range between 32° F and 150° F, and the humidity should not exceed 90%.

C. Power supply

Make sure that the variation in the power supply is never more or less than 10 % of the RATING value. Higher values may cause damage to the electronic components. PRESFLO® can only be used with single-phase pumps.



Safety regulations

Before installing or using PRESFLO®, read this manual carefully and thoroughly. The pump should be installed and serviced by qualified personnel, responsible for making the hydraulic and electrical connections in compliance with the relevant regulations.

DGFLOW® shall not be held liable for any damage relating to, or resulting from, an improper use of the product, or for any damage relating to, or resulting from, servicing or repairs carried out by unqualified personnel and/or with non-OEM spare parts.

The warranty, which is valid for 24 months from the date of purchase, will no longer be applicable should the product suffer damage as a consequence of the use of non-OEM spare parts, tampering or improper use.

When starting the installation, check the following:

- the power supply is switched off.
 - the power lines can withstand the maximum current.
 - the cable bushings and circuit board cover have been properly assembled and secured (see Electrical Connections).
 - the power supply is fitted with regulation earthing and safety devices.
- When servicing the product, check the following:
- the system is not pressurised (turn a tap on)
 - the power supply is switched off.

EMERGENCY STOP

- When in use, the pump can be topped in the event of an emergency: press START/STOP.

PRESFLO® is put OUT OF SERVICE.

For no reason, disassemble the water accumulator with the



Installation

Preliminary checks

Take the PRESFLO® out of the packaging and check the following:

- check for damage,
- check the RATINGS correspond with those required,
- that the cable bushings and screws are in place,
- that PRESFLO®'s inlets and outlets are clean and free of any packaging materials,
- that the check valve moves smoothly.

Hydraulic connections

Orientation

PRESFLO® can be installed at any angle depending on the flow direction, as indicated in the diagrams.

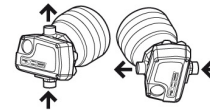

Positioning. PRESFLO® can be fitted directly onto the pump outlet in any position of the delivery line. Never install taps between the pump and PRESFLO®. Do not install a non-return valve between PRESFLO® and the taps, meanwhile it is possible, although not necessary, to install a non-return valve on the suction piping of the pump.

ATTENTION

The pressure applied by the water column above PRESFLO® must not exceed that of the pump start-up pressure (P_m). If, for example, PRESFLO® is installed at a height 65 feet below that of the highest tap in the system, the pressure detected by PRESFLO® will be approximately 28 psi. A model with $P_m = 35$ psi should, therefore, be installed in order to guarantee that the pump is started when a tap is turned on.

ATTENTION

The maximum pressure produced by the pump must be at least 5 - 30 psi higher than the start-up pressure (P_m). If the pressure produced by the pump is too low, PRESFLO® will stop the pump and indicate a 'dry running' error message.

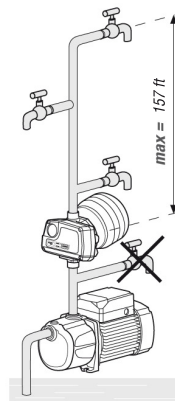

Electrical connections

The electrical connections should be made as indicated in the diagram which can also be found on the inside of the circuit cover.

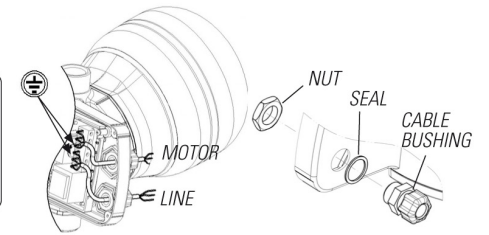
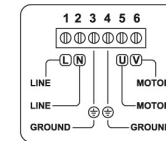

ATTENTION

The cable bushings and circuit board cover must be properly assembled and secured in order to guarantee IP 65 grade protection of the electrical components.

STATEMENT OF COMPLIANCE

Under our exclusive responsibility, we hereby declare that this product is compliant with the following EU Directive and relevant implementing national regulations:

73/23/CEE, 89/336/CEE, EN 60730-2-6, EN 61000-6-3

DGFLOW S.r.l.
President - Amministratore Unico
Stefano Concini

Bigarello 12.11.08

First start-up

Priming the pump

For instructions on how to prime (fill) the pump, see the pump manual.

ATTENTION

PRESFLO® is fitted with a check valve: do not use the PRESFLO®'s outlet to fill the pump for priming.

Switching on the pump.

The LCD displays the MODEL, then the red (Power) LED lights up and the system pressure is displayed. If this is lower than the RP, the pump starts-up (the green Status LED lights up).

If within 15 seconds from the start-up of PRESFLO® the correct priming is not detected, the pump is stopped due to a dry running anomaly.



ATTENTION

When the pump is started for the first time, it may have to be run for longer in order to complete the priming procedure.

Press the START/STOP button to restart the pump and complete the priming procedure.



Disposal

When disposing of any PRESFLO® parts, adhere to the relevant laws and regulations in force in the country in which the equipment is being used. Do not dispose of any polluting parts in the environment.



Operation

1

No power supply

PRESFLO® is switched off.

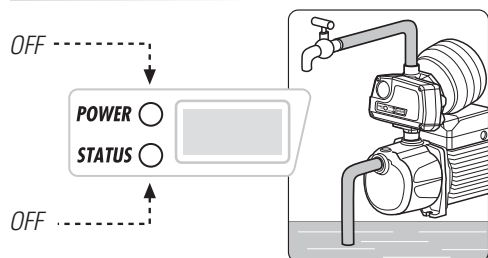

PRESS BRIEFLY or HOLD DOWN
= nothing happens



Power is restored
= PRESFLO® resumes NORMAL SERVICE and starts the pump (if necessary).

2a

NORMAL SERVICE: The pump is inactive.

The system is pressurised. All taps are turned off. There is no demand for water. PRESFLO® detects an assembly pressure higher than that of the start-up pressure (P_m) and no flow.

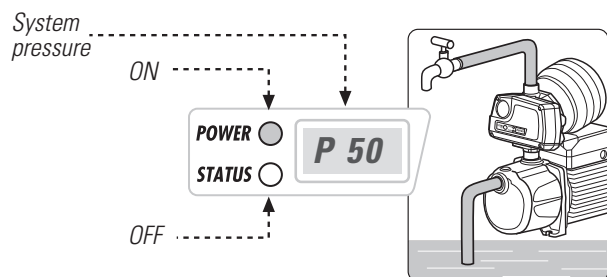

PRESS BRIEFLY
= the pump is started manually and runs for a few seconds before stopping again.

HOLD DOWN
= the pump is put OUT OF SERVICE. For instructions on how to reactivate the pump, see point 3.



A tap is turned on
= as soon as the pressure falls below the start-up pressure (P_m), the pump is started.

2b

NORMAL SERVICE: The pump is running.

The assembly requires water. One or more taps are turned on. PRESFLO® detects a flow; the assembly pressure is normally higher than the START-UP pressure, but it may also be lower.

System pressure

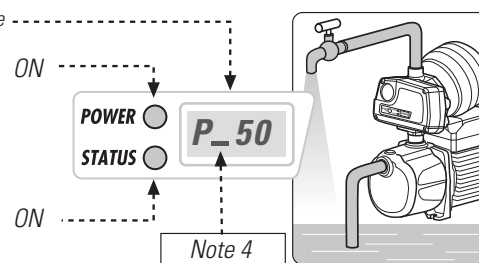

PRESS BRIEFLY or HOLD DOWN
= the pump is stopped and put OUT OF SERVICE. For instructions on how to reactivate the pump, see point 3.



The taps are turned off
= If there is no flow for a few seconds, the pump is stopped.

3

OUT OF SERVICE

The pump has been stopped manually. The pump will remain inactive until a new command is given.

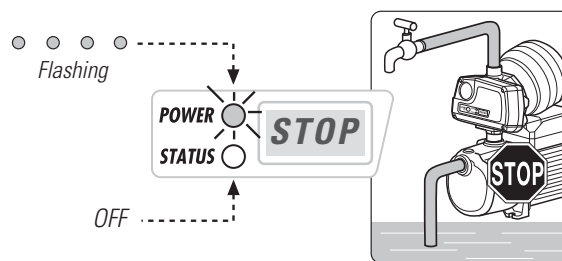

PRESS BRIEFLY
= nothing happens.

HOLD DOWN
= the pump resumes NORMAL SERVICE. See points 2a - 2b.

4a

ERROR: stopped temporarily due to DRY RUNNING (See NOTE 1)

PRESFLO® has detected that the pump is dry running and has therefore stopped it TEMPORARILY.

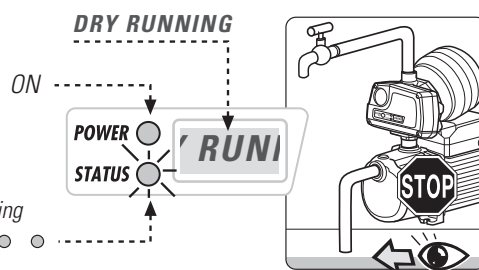

Operation

4a



PRESS BRIEFLY
= the pump is started and resumes NORMAL SERVICE. See points 2a - 2b.

HOLD DOWN
= the pump is put OUT OF SERVICE. For instructions on how to reactivate the pump, see point 3.

4b

ERROR: temporary shut down due to FREQUENT START UP (see NOTE 2)

PRESFLO® has detected that the pump starting-up too often and has therefore stopped it TEMPORARILY.

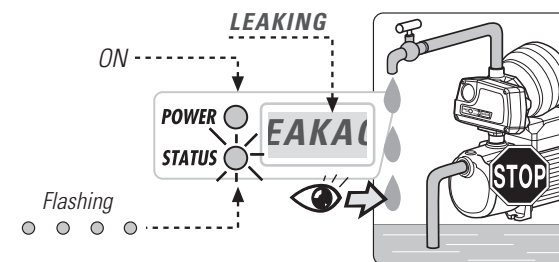

PRESS BRIEFLY
= the pump is started manually and resumes NORMAL SERVICE. See points 2a - 2b.

HOLD DOWN
= the pump is put OUT OF SERVICE. For instructions on how to reactivate the pump, see point 3.

4c

ERROR: stop due to overload.

PRESFLO® has detected a current exceeding the max. allowed and has the pump stopped.

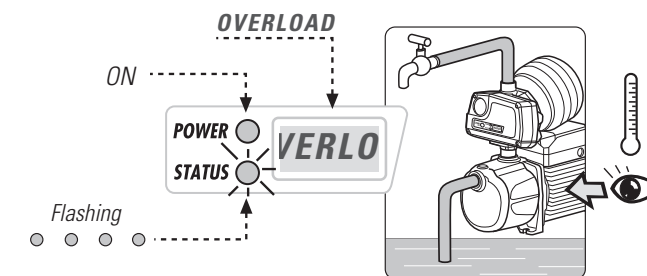

PRESS BRIEFLY
= the pump is started manually and runs for a few seconds before stopping again.

HOLD DOWN
= the pump is put OUT OF SERVICE. For instructions on how to reactivate the pump, see point 3.

Exploded view of spare parts

ATTENTION: when ordering spare parts, always state the position n° from the diagram below and the product code number found in the pressure-flow regulator technical data table.

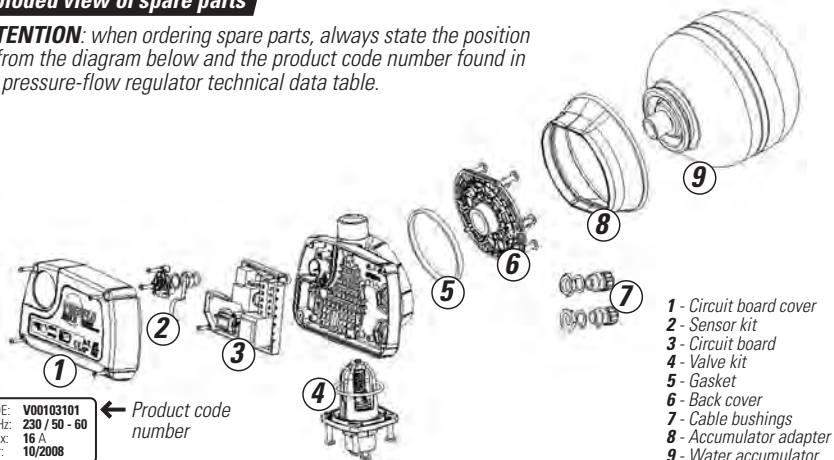

CODE: **V00103101** ← Product code number
 V / Hz: **230 / 50 - 60**
 I max: **16 A**
 Year: **10/2008**

- 1 - Circuit board cover
- 2 - Sensor kit
- 3 - Circuit board
- 4 - Valve kit
- 5 - Gasket
- 6 - Back cover
- 7 - Cable bushings
- 8 - Accumulator adapter
- 9 - Water accumulator

Dimensions

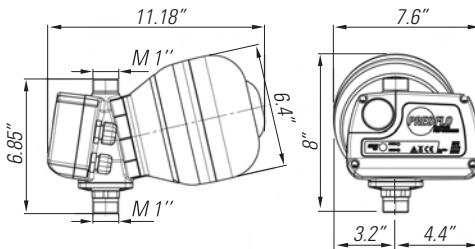

NOTE 1
DRY RUNNING = there is no flow and the pressure is lower than that of the pump start-up pressure (Pm).

It occurs when there is no water. After 15 seconds PRESFLO® stops the pump and indicates an ERROR message. PRESFLO® AUTOMATICALLY tries to resume NORMAL SERVICE at intervals of increasing time (15, 30, 60 minutes and successively once every hour). If PRESFLO® detects any pressure and/or flow, NORMAL SERVICE is resumed, otherwise, the pump is stopped again until the next attempt is made. A MANUAL attempt to resume NORMAL SERVICE can be made at any time.

NOTE 2
FREQUENT START-UP = the repeated stopping and starting of the pump at intervals of less than 2 minutes from each other. This occurs when the flow rate is less than 0.25 - 0.5 GPM.

This may cause damage to the pump. In event of small leaks (dripping), PRESFLO®'s water accumulator guarantees that the pump starts/stops at time intervals of over 2 minutes (less than 30 starts/hour) and that FREQUENT START-UP errors do not occur. In the event of a major leak or extended use at excessively low flow rates (less than 0,25 - 0,5 GPM), combined with deflated water accumulator the pump may be started/stopped as often as once every few seconds, putting the pump at risk of damage. In this case, after about 30 minutes, PRESFLO® stops the pump for the following 30 minutes (in order to let it cool down) and indicates an ERROR message. If the time interval between the starts-stops is more than 10 seconds (and therefore poses less of a risk to the pump), PRESFLO® will allow the pump to be used for more than 30 minutes. Once that enough time has passed to allow the pump to cool down it is restarted AUTOMATICALLY. The pump may be restarted MANUALLY any time.

Problems	Possible causes	Solutions	Signals
PRESFLO® will not turn on.	A - No power	A - Check the electrical connections	A OFF POWER OFF STATUS
	B1 - The restart pressure (Pm) setting is unsuitable to the type of installation.	B1 - Set the Pm at a higher value.	B1 ON POWER OFF STATUS P 33
	B2 - Faulty electrical connections or pump out of service.	B2 - Check the electrical connections and that the pump is working	B2 ON POWER ON STATUS P 30
	B3 - PRESFLO® "OUT OF SERVICE"	B3 - Reset PRESFLO® (See Operation, point 3).	B3 Flashing ON POWER STATUS STOP
The pump will not start when a tap is turned on.	B4-1 - PRESFLO® in temporary shut down due to "DRY RUNNING" due to lack of water	B4-1 - Wait for the automatic restart or press START to restart manually (See Operation, point 4a)	B4 DRY RUNNING ON POWER Flashing STATUS STOP
	B4-2 - Maximum pump pressure is insufficient	B4-2-1 - Replace the pump with one with more suitable characteristics B4-2-2 - Set Pm at a lower value	
	B5 - PRESFLO® in temporary shut down due to "FREQUENT START-UP"	B5 - Wait for the automatic restart or press START to restart manually (See Operation, point 4b). Remove any cause of leakage from system and check the accumulator pressure	B5 LEAKAGE ON POWER Flashing STATUS AKAGE
	B6 - PRESFLO® stops due to "OVERCURRENT"	B6 - Check if the setting of the maximum current (Imax) is congruent with the data of the pumps' rating plate. If after manually restarting the pump after correctly setting PRESFLO®, it again signals an anomaly, check that the motor has no mechanical or electrical problems.	B6 OVERLOAD ON POWER Flashing STATUS VERLOA
The pump delivers no or low pressure.	C-1 - Filters or pipes may be partly blocked	C-1 - Check the water pipes	C ON POWER ON STATUS P 40
	C-2 - PRESFLO®'s valve will not open completely	C-2 - Check that the valve is not blocked by any foreign objects and clean if necessary	
The pump stops and starts repeatedly.	D - Leaks within the system (less than the shut-off flow rate Qa)	D - Check the hydraulic connections and repair any leaks	D ON POWER ON STATUS ON POWER OFF STATUS OFF STATUS
The pump will not stop.	E-1 - The flow rate is higher than the shut-off flow rate (Qa)	E-1 - Make sure that all taps are turned off and that there are no leaks within the system	E ON POWER ON STATUS P_50
	E-2 - PRESFLO®'s check valve will not close	E-2 - Check that the valve is not blocked by any foreign objects and clean if necessary	

NOTE 3
OVERCURRENT = electric absorption of the pump (in Ampere) exceeding the max. allowed (I max).

By means of the configuration, it is possible to set the max. current allowed (I max). During the start-up phase of the pump PRESFLO® allows for a few seconds the current to exceed the I max value. If the absorptions remain above the set I max value, PRESFLO® stops the pump to avoid damaging the motor and signals an anomaly. PRESFLO® will not automatically restart the pump. The pump may be MANUALLY restarted at any moment. Should the problem persist an anomaly will again be signalled. The manual restart can be repeated several times since PRESFLO® does not limit the number of attempts.

NOTE 4
SHUT-OFF FLOW RATE =

Flow rate (Qa) of around 0,25 - 0,5 GPM below which PRESFLO® stops the pump. If the flow rate is HIGHER than the stop flow rate (Qa), the displays shows a hyphen after the letter P.