



INSTALLATION INSTRUCTIONS FOR PART 99-7805CH

APPLICATIONS

Acura TSX (without nav) 2009-2014 99-7805CH

KIT FEATURES

- ISO DIN radio provision with pocket
- *Painted charcoal gray*



KIT COMPONENTS

- A) Radio trim panel • B) Radio brackets • C) Pocket • D) (4) #8 x 3/8" Truss-head Phillips screws
- E) (2) #8 x 1/2" Truss-head Phillips screws • F) (4) #8 x 3/8" Pan-head Phillips screws

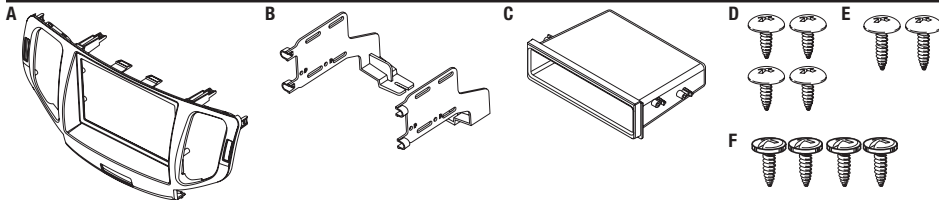

WIRING & ANTENNA CONNECTIONS (sold separately)

- Wiring Harness: • 70-1729 - *For non-amplified models*
• 70-1730 - *For amplified models*

Antenna Adapter: • 40-HD10

Table of Contents

Dash Disassembly

- Acura TSX (without nav) 2009-2014.....2-5

Kit Assembly

- ISO DIN radio provision with pocket..... 6

TOOLS REQUIRED

- Panel removal tool • Phillips screwdriver
- Socket wrench

CAUTION: *Metra recommends disconnecting the negative battery terminal before beginning any installation. All accessories, switches, and especially air bag indicator lights must be plugged in before reconnecting the battery or cycling the ignition.*

NOTE: *Refer to the instructions included with the aftermarket radio.*

Dash Disassembly

1. Unclip and remove the trim panel above the glove box on the passenger side of the dash. (Figure A)
2. Unclip and remove the driver and passenger side trim panels from the console. (Figure B and C)

Continued on next page

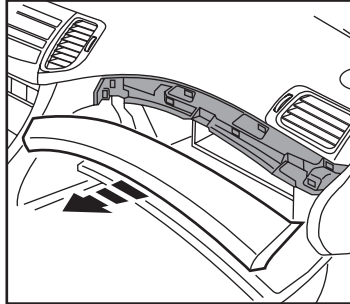

(Figure A)

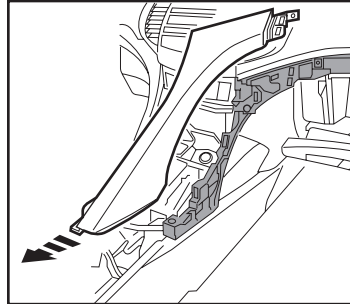

(Figure B)

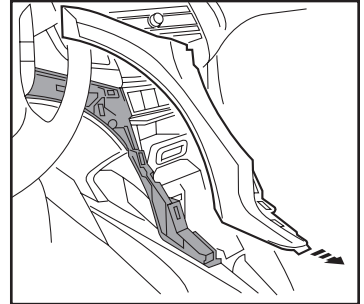

(Figure C)

Dash Disassembly

3. Unclip and remove the shifter panel including the cup holders. (Figure D)
4. Unclip and remove the coin holder from the 12-volt socket/coin holder assembly. (Figure E)

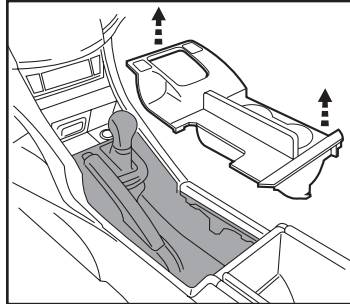

(Figure D)

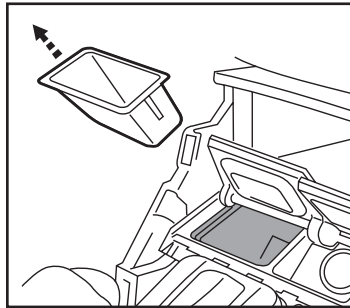

(Figure E)

5. Remove (1) Phillips screw under the coin holder, and then unclip and remove the 12-volt socket/coin holder assembly. (Figure F)
6. Remove (4) Phillips screws securing the pocket assembly then unclip and remove the pocket. (Figure G)

Continued on next page

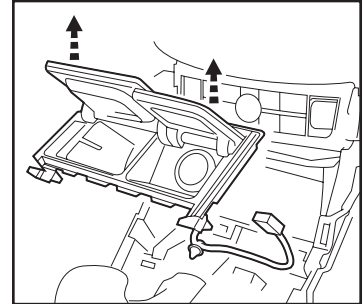

(Figure F)

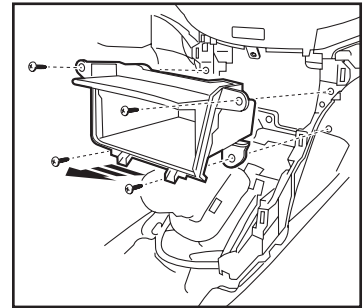

(Figure G)

Dash Disassembly

7. Remove (4) Phillips screws securing the climate control then unplug and remove the control. (Figure H)
8. Remove (2) Phillips screws facing up under factory radio. (Figure I)
9. Remove (2) Phillips screws securing the hazard switch.
10. Remove the (4) plastic clips from the factory radio assembly.

Continued on next page

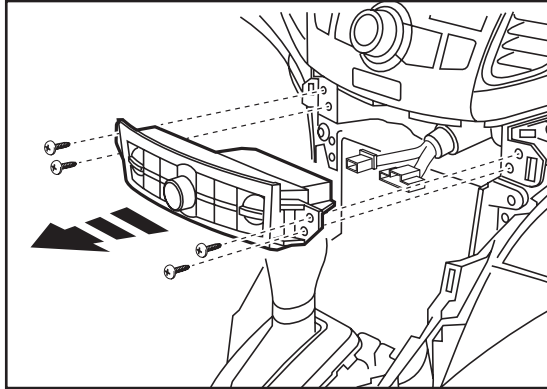

(Figure H)

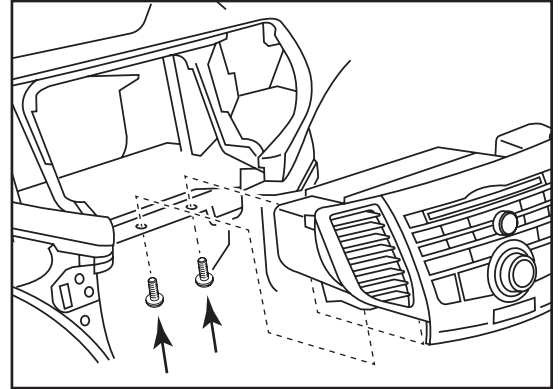

(Figure I)

Dash Disassembly

11. Remove (2) Phillips screws per vent securing the a/c vents to the radio panel then unclip and remove the vents. (Figure J)

Continue to kit assembly

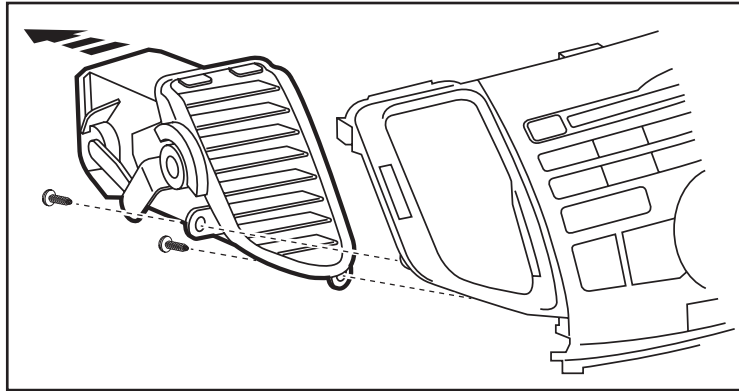

(Figure J)

Kit Assembly

ISO DIN radio provision

1. Attach (4) panel clips to the radio trim panel using (4) panel clips supplied. (Figure A)
2. Mount the pocket to the radio brackets with (4) #8 x 3/8" truss-head Phillips screws supplied. (Figure B)
3. Mount the bracket/pocket assembly to the radio trim panel with (4) #8 x 3/8" Pan-head Phillips screws supplied. (Figure C)

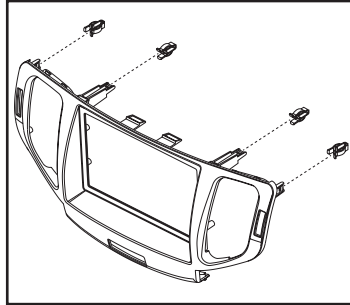

(Figure A)

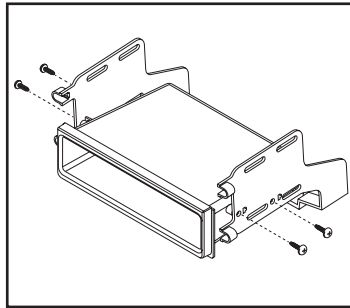

(Figure B)

4. Slide the radio into the completed assembly and secure with screws supplied with the radio. (Figure D)
5. Attach the A/C vents to the radio housing using the factory hardware.
6. Attach the hazard switch to the radio housing using (2) #8 x 1/2" Truss-head Phillips screws supplied.
7. Locate the factory wiring harness and antenna plug in the dash. Metra recommends using the proper mating adapters from Metra and/or AXCESS.
8. Reassemble the dash in reverse order of disassembly.

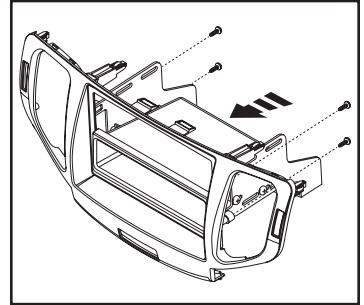

(Figure C)

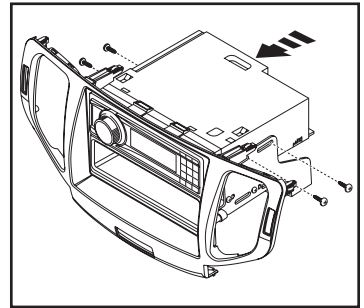

(Figure D)



INSTALLATION INSTRUCTIONS FOR PART 99-7805CH



REV. 4/24/2015 INST99-7805CH



KNOWLEDGE IS POWER

Enhance your installation and fabrication skills by enrolling in the most recognized and respected mobile electronics school in our industry. Log onto www.installerinstitute.com or call 800-354-6782 for more information and take steps toward a better tomorrow.



Metra recommends MECP certified technicians



INSTRUCCIONES DE INSTALACIÓN PARA LA PIEZA 99-7805CH

APLICACIONES

Acura TSX (sin nav) 2009-2014 99-7805CH

CARACTERÍSTICAS DEL KIT

- Provisión de radio ISO DIN con cavidad
- *Gris carbón pintado*



COMPONENTES DEL KIT

- A) Panel de ajuste de radio • B) Soportes de radio • C) Cavidad • D) (4) tornillos Phillips de cabeza segmentada #8 x 3/8" • E) (4) tornillos Phillips de cabeza segmentada #8 x 1/2" • F) (4) tornillos Phillips de cabeza troncocónica #8 x 3/8"

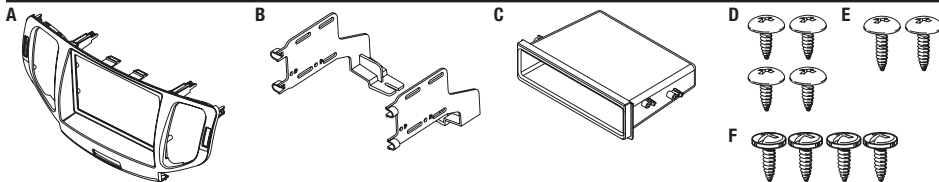

CABLEADO Y CONEXIONES DE ANTENA (se venden por separado)

- Arnés de cables: • 70-1729 - Para los modelos no amplificados
 • 70-1730 - Para los modelos amplificados
- Adaptador de antena: • 40-HD10

Índice

Desmontaje del tablero

- Acura TSX (sin nav) 2009-2014..... 2

Ensamble del kit

- Provisión de radio ISO DIN con cavidad..... 3

HERRAMIENTAS REQUERIDAS

- Herramienta para quitar paneles
- Destornillador Phillips • Llave para dados

PRECAUCIÓN: *Metra recomienda desconectar el terminal negativo de la batería antes de comenzar cualquier instalación. Todos los accesorios, interruptores y, especialmente, las luces indicadoras de airbag deben estar enchufados antes de volver a conectar la batería o comenzar el ciclo de ignición.*

Nota: *Remítase a las instrucciones incluidas con el radio de posventa.*

Desmontaje del tablero

1. Desenganche y quite el panel de moldura que está sobre la guantera del lado del pasajero en el tablero. (Figura A)
2. Desenganche y quite los paneles de moldura del lado del conductor y del pasajero de la consola. (Figura B, C)

Continúa en la página siguiente

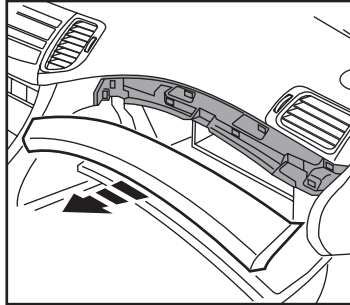

(Figura A)

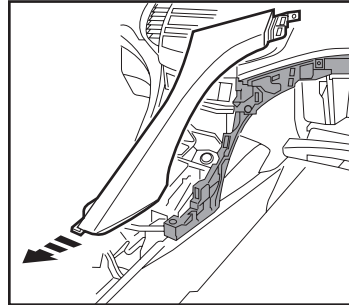

(Figura B)

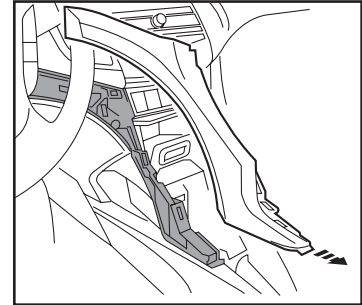

(Figura C)

Desmontaje del tablero

3. Desenganche y quite el panel de la palanca de velocidades, incluyendo los portavasos. (Figura D)
4. Desenganche y quite el portamonedas del ensamble del tomacorriente de 12 voltios/ portamonedas. (Figura E)

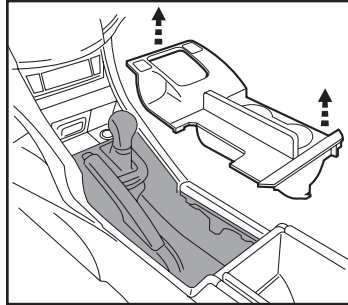

(Figura D)

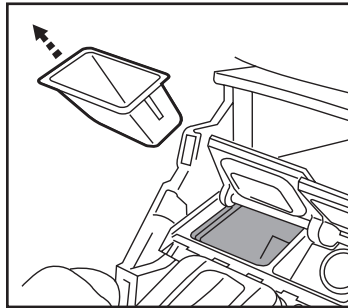

(Figura E)

5. Quite (1) tornillo Phillips de abajo del portamonedas y luego desenganche y quite el ensamble del tomacorriente de 12 voltios/ portamonedas. (Figura F)
6. Quite los (4) tornillos Phillips que sujetan el ensamble de la cavidad, luego desenganche y quite la cavidad. (Figura G)

Continúa en la página siguiente

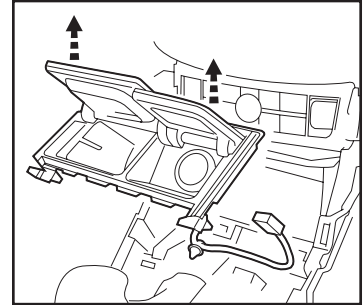

(Figura F)

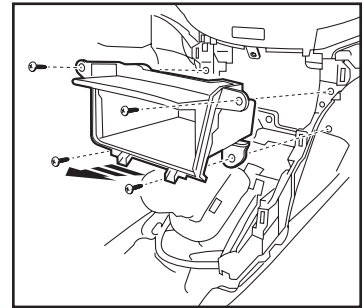

(Figura G)

Desmontaje del tablero

7. Quite los (4) tornillos Phillips que sujetan el control de clima y luego desenganche y quite el control. (Figura H)
8. Quite los (2) tornillos Phillips orientados hacia arriba de debajo del radio de fábrica. (Figura I)
9. Quite los (2) tornillos Phillips que sujetan el interruptor de las luces intermitentes.
10. Quite los (4) ganchos de plástico del ensamble del radio de fábrica.

Continúa en la página siguiente

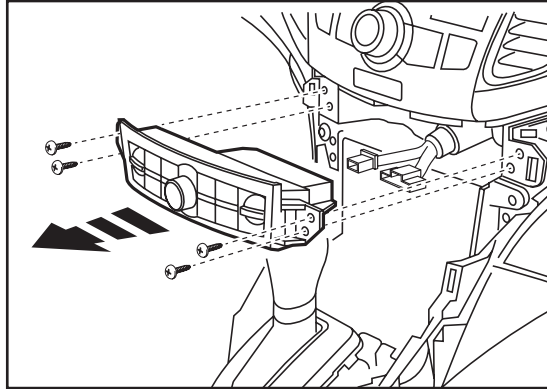

(Figura H)

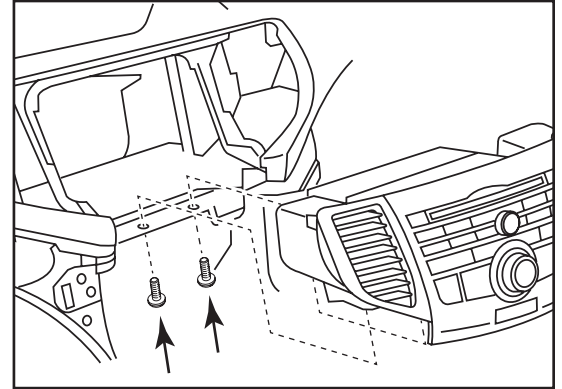

(Figura I)

Desmontaje del tablero

11. Quite los (2) tornillos Phillips que sujetan cada rejilla de aire acondicionado al panel del radio y luego desenganche y quite las rejillas. (Figura J)

Continúe kit de montaje

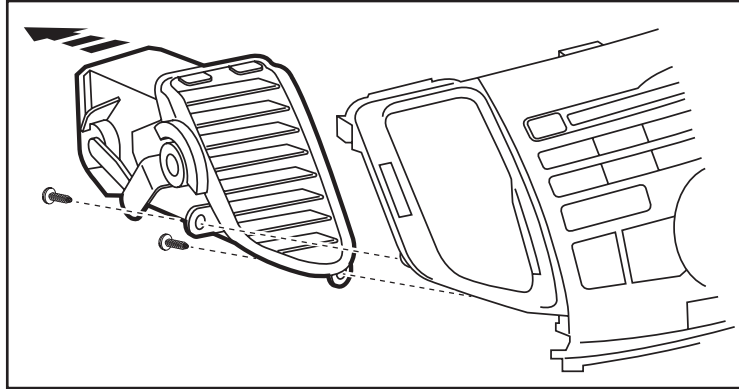

(Figura J)

Ensamble del kit

Provisiones de radio ISO DIN

1. Coloque los (4) ganchos del panel a la panel de ajuste de radio que utiliza (4) Panel clips suministrados. (Figura A)
2. Monte la cavidad en los soportes del radio con los (4) tornillos Phillips de cabeza segmentada #8 x 3/8" suministrados. (Figura B)
3. Monte el ensamble del soporte/la cavidad en la carcasa del radio con los (4) tornillos Phillips de cabeza troncocónica #8 x 3/8" incluidos. (Figura C)

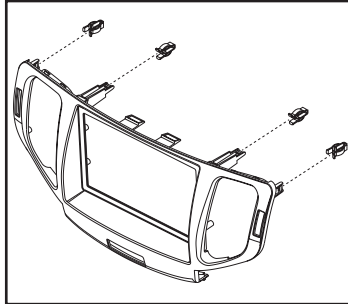

(Figura A)

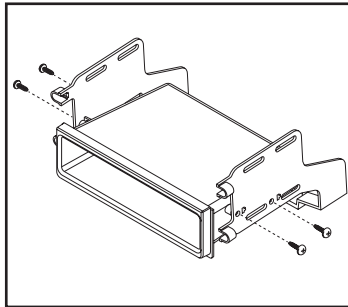

(Figura B)

4. Deslice el radio en el ensamblaje completo y sujételo con los tornillos suministrados con el radio. (Figure D)
5. Coloque las rejillas del aire acondicionado en la carcasa del radio usando la tornillería de fábrica.
6. Coloque el interruptor de las luces intermitentes en la carcasa del radio con los (2) tornillos Phillips de cabeza segmentada #8 x 1/2" suministrados.
7. Ubique el arnés de cableado de fábrica y el conector de la antena en el tablero. Metra recomienda el uso de adaptadores adecuados de acoplamiento de Metra y/o de AXCESS.
8. Vuelva a armar el tablero al revés de como lo desarmó.

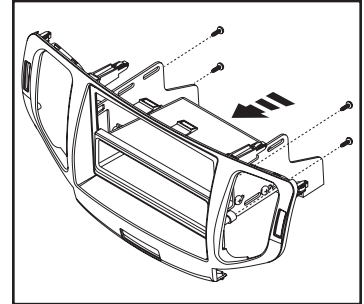

(Figura C)

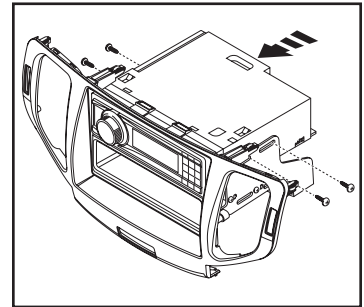

(Figura D)



INSTRUCCIONES DE INSTALACIÓN PARA LA PIEZA 99-7805CH



REV. 2/27/2014 INST99-7805CH



EL CONOCIMIENTO ES PODER

Mejora sus habilidades de instalación y fabricación inscribiéndose en la escuela de dispositivos electrónicos móviles más reconocida y respetada de nuestra industria. Regístrese en www.installerinstitute.com o llame al 800-354-6782 para obtener más información y avance hacia un futuro mejor.



Metra recomienda técnicos con certificación del Programa de Certificación en Electrónica Móvil (Mobile Electronics Certification Program, MECP).