

Peninsula Desk

MJ/FL/ML/WH2047

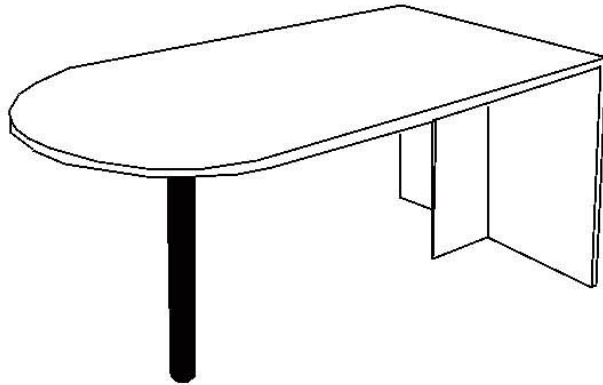

ASSEMBLY INSTRUCTIONS

PARTS LIST

Part	Part
 Wood Dowel	 Cap
 Cam Pin	 Leveling Glide
 Cam Lock	
 Screw	

For MJ (Cherry), ML (Maple) and WH (White) Peninsula Desks, follow these instructions:

You will be assembling your peninsula desk like shown below. Assemble on carpet or cardboard to avoid scratching during assembly.

Tools Need: Phillips Screwdriver

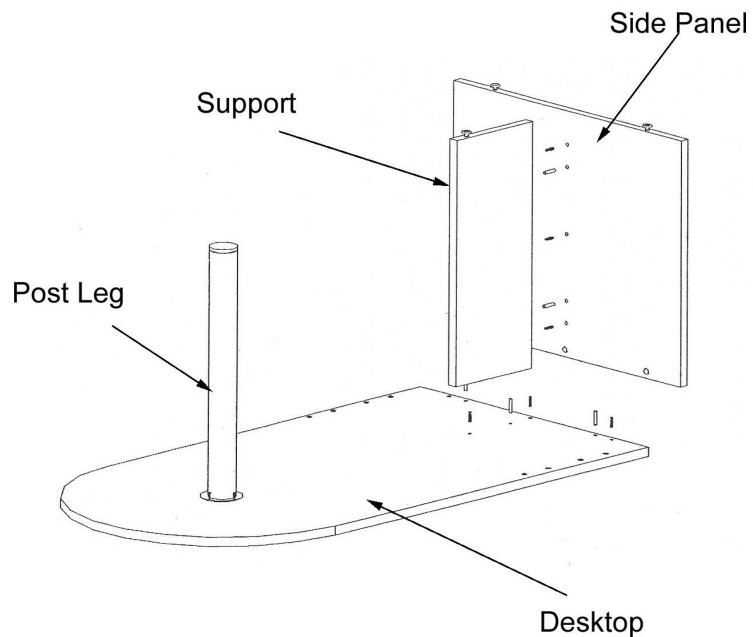

2

- 1.) Assemble side panel and support using the cam locks, cam pins and wooden dowels provided.

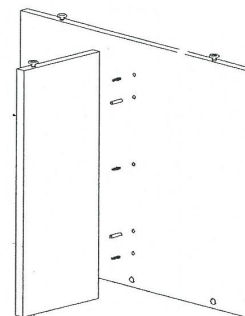

- 2.) Then, set the side panel/support assemble onto the desktop. Attach with dowels, cam pins and cam locks

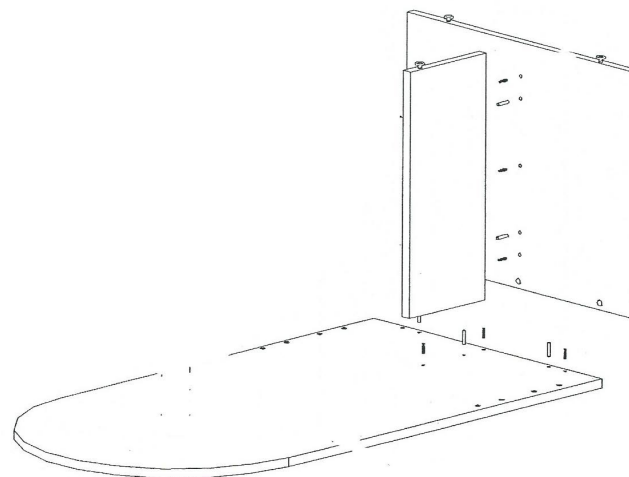

- 3.) Attach Leveling Glides to Side Panel and Support.

3

MJ (Cherry), ML (Maple) and WH (White)
instructions continued....

4.) Attach the post leg to the center of the underside of the desktop with the screws provided.

5.) Lastly, carefully turn desk upright and place the cam lock covers over the silver cam locks.

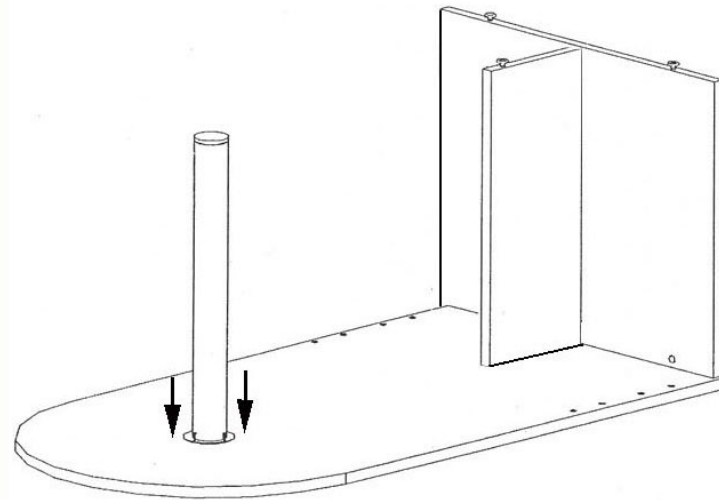

**For FL (Mocha) Peninsula Desk with
modesty panel, follow these instructions:**

You will be assembling your peninsula desk like shown below.
Assemble on carpet or cardboard to avoid scratching during
assembly.

Tools Need: Phillips Screwdriver

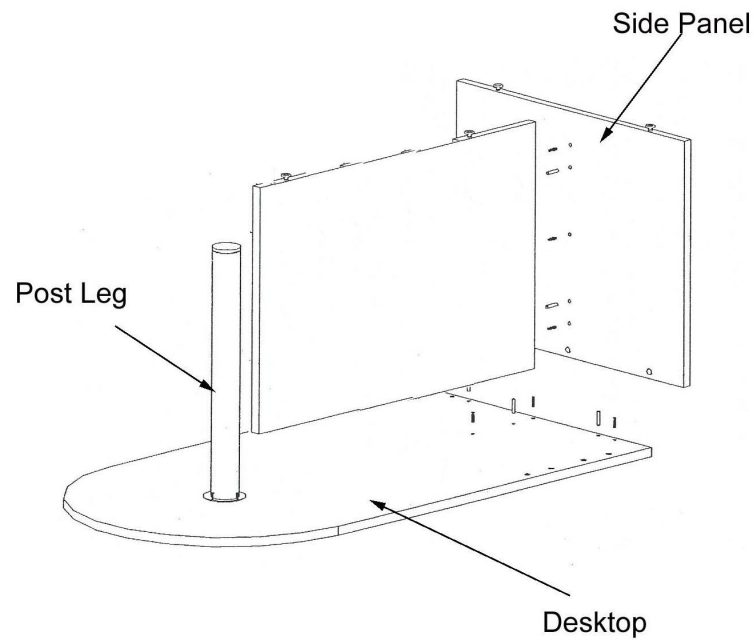

- 1.) Assemble side panel and support using the cam locks, cam pins and wooden dowels provided.

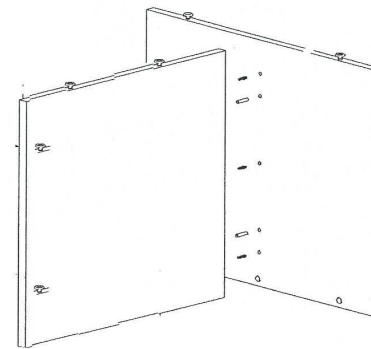

- 2.) Then, set the side panel/support assemble onto the desktop.
Attach with dowels, cam pins and cam locks

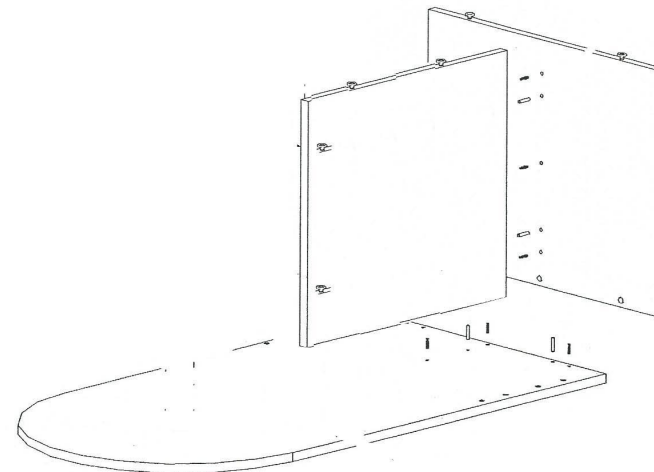

- 3.) Attach Leveling Glides to Side Panel and Support.

**FL (Mocha) Peninsula Desk
instructions continued....**

- 4.) Attach the post leg to the modesty panel using two cam pins & locks. Pins fit inside holes in leg. Then, Attach the post leg to the center of the underside of the desktop with the screws provided.
- 5.) Lastly, carefully turn desk upright and place the cam lock covers over the silver cam locks.

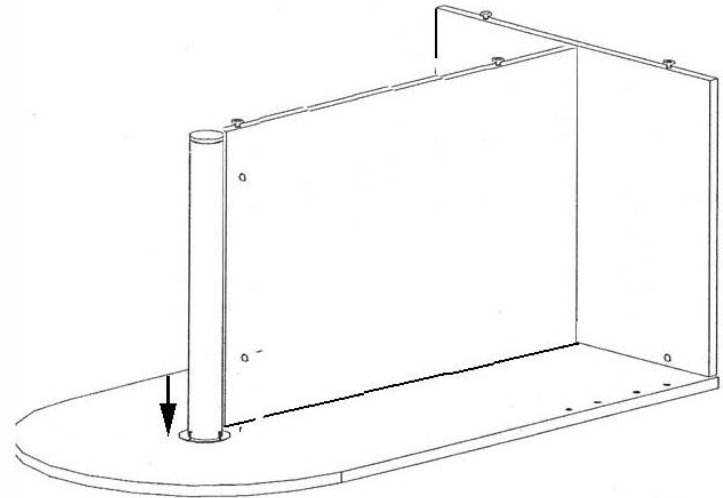



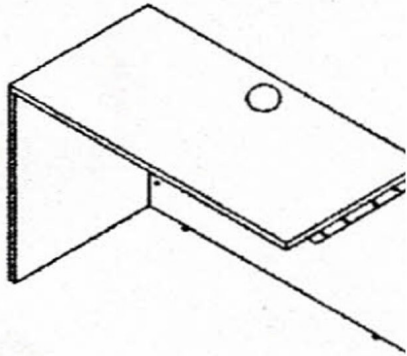







Reversible Desk Return MJ/FL/ML/WH2045

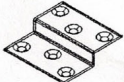

ASSEMBLY INSTRUCTIONS

PARTS LIST

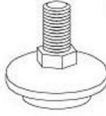
Part	Part	Part
 Wood Dowel	 Shallow Cover	 Worksurface Bracket
 Cam Pin	 Deep Cover	 Side Panel Brackets (2)
 Cam Lock	 Grommet	 M6 Screw
 Wood Screw	 L-Bracket	 Leveling Glide



Modern Office
6900 Shady Oak Road, Ste 120
Eden Prairie, MN 55344
Phone: 800.443.5117
(In MN): 952-941-2837
Fax: 952.949.9816
www.modernofficefurniture.com

Left Return

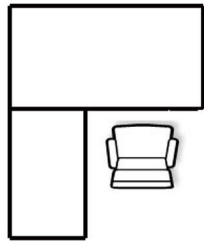

Right Return

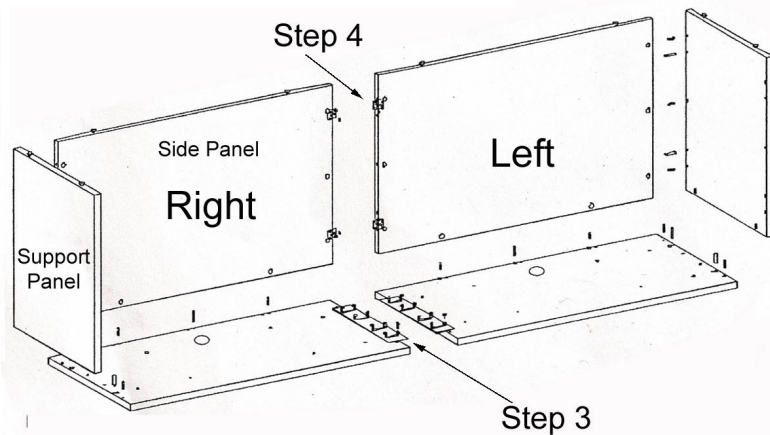
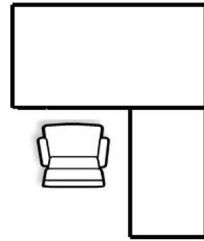

Assemble upside down in carpeted area

Step 1:
Determine if return desk is to be Left or Right.

Step 2:
Attach Side Panel and Support Panel using dowels, cam locks and cam pins provided.

Step 3:
Using M6 Screws, attach flat bracket to edge of return as shown in the photo, centering it over the edge.

Step 4:
Using wood screws provided, attach both side panel offset brackets to the side panel as shown.

Step 5:
Screw in floor glides.

Step 6:
Carefully turn over return desk and attach to main desk using M6 screws, connecting other side of flat bracket to underside of main desk

Step 7:
Insert grommet and covers. Shallow covers go over cams on side panel, deep covers go over cams on support panel, since those are more inset.

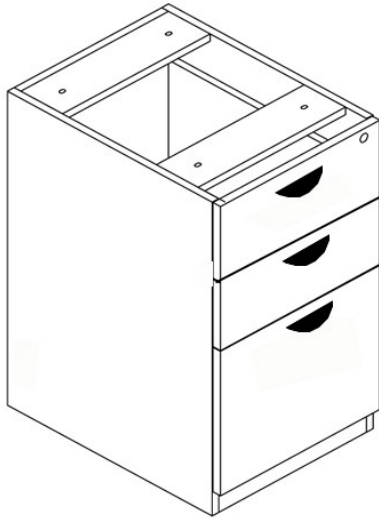

Box/Box/File Pedestal

MJ/FL/ML/WH2066



Install Instructions

PARTS LIST

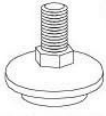
Part	Part
 Bolt	 Drawer Pull & Screws
 Keys	 Leveling Glide

- 1) Install 4 leveling glides and level the file
- 2.) Install drawer pulls with screws provided.

To attached under desk (optional):

- 1.) Remove 1 or 2 of the box drawers by locating the black tabs in the left & right side of the drawer. Pull up on one tab, push down on the other to unlock from the track and remove drawer.
- 2.) Use 4 bolts provided to go through the top of the file into the threaded holes on the underside of the desk.





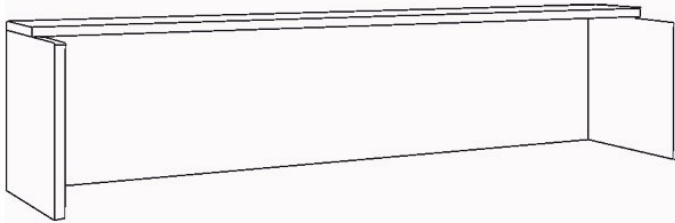

Modern Office
6900 Shady Oak Road, Ste 120
Eden Prairie, MN 55344
Phone: 800.443.5117
(In MN): 952.941.2837
Fax: 952.949.9816
www.modernofficefurniture.com

66" & 71" White Desktop Risers



WH2095 & WH2090

PARTS LIST

Part	Part
 Wood Dowel	 Shallow Cover
 Cam Pin	
 Cam Lock	 Deep Cover



Modern Office
6900 Shady Oak Road, Ste 120
Eden Prairie, MN 55344
Phone: 800.443.5117
(In MN): 952-941-2837
Fax: 952.949.9816
www.modernofficefurniture.com

Assemble on a smooth, clean surface to prevent scratches.

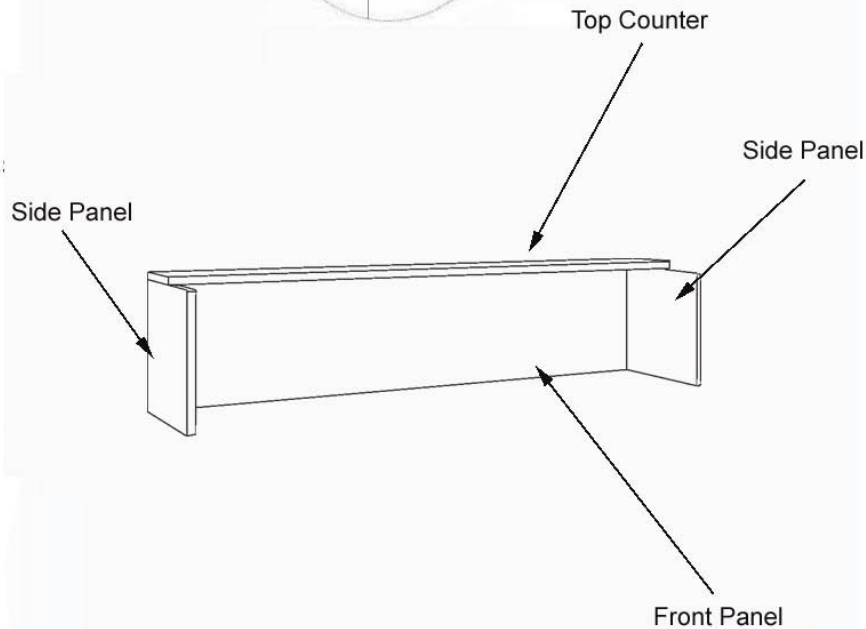
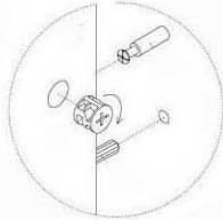

Modern Office
6900 Shady Oak Road, Ste 120
Eden Prairie, MN 55344
Phone: 800.443.5117
(In MN): 952-941-2837
Fax: 952.949.9816
www.modernofficefurniture.com

- 1.) First, attach FRONT PANEL to one of the SIDE PANELS using the cam lock and cam pin sets provided. DO NOT YET FULLY TIGHTEN DOWN THE CAM LOCKS. That will be towards the end.
- 2.) Next, attach the other SIDE PANEL using same method.
- 3.) Now, insert any/all wooden dowels, cam locks and pins into the FRONT PANEL to attach the TOP COUNTER.
- 4.) Once all panels are connect, fully tighten all cam locks.
- 5.) Place in area of intended use and use covers to cover over the cam locks.
- 6.) Double Sided tape on bottom of side panels secures the riser to the desktop.