

2-Door Cabinet Assembly Instructions

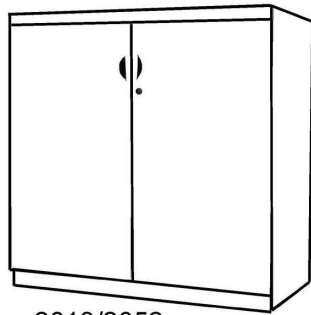

2013/2052

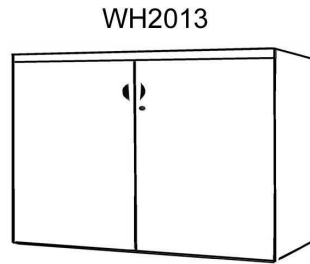

WH2013

Applies Towards:

FL/ML/MJ/WH2013











WH2013A

FL/ML/MJ2052

Tools Needed:

- Phillips Screwdriver
- A Helper

List of Hardware:

| | | |
|--|---|---|
|  Wood Dowel |  Shelf Pin |  Hinge |
|  Cam Pin |  Plunger Lock |  Hinge Plate |
|  Cam Lock |  Leveling Glide |  Lock/Key |
|  Door Pull |  Shallow Cover |  Deep Cover |

Step 1.) For 2013 and 2052 cabinets only. Attach Toe Kick to Bottom Panel with cam pins & locks. Assemble upside down.

Step 2.) (For all cabinets) Attach Back Panel to Bottom Panel with cam pins & locks.

Step 3.) Attach Left & Right Side Panels in same manner.

Step 4.) Attach Top Surface with cam locks, cam pins and dowels. Then, insert the four leveling glides.

Step 5.) Insert shelf pins into holes along the interior sides. Place Shelf on top of the pins.

Step 6.) Attach four hinge plates with the screws included. The holes are piloted. DO NOT TIGHTEN ALL OF THE WAY! LEAVE WIGGLE ROOM FOR ADJUSTMENT LATER ON.

Special Note:

Location & number of cam pin, cam lock and dowel holes may vary.

Step 1



Step 3

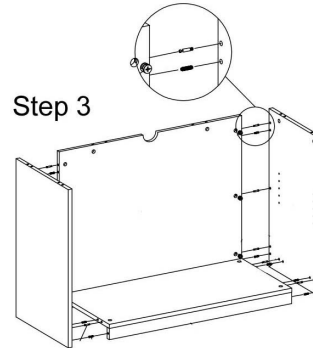

Step 5

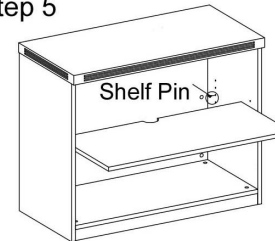

Hinge Adjustment

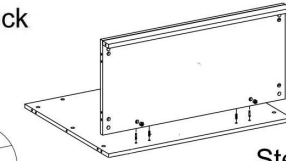

Step 2

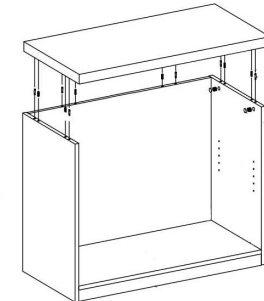

Step 4

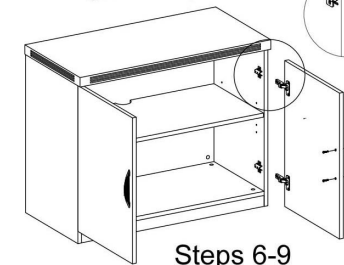

Steps 6-9

Step 7.) Attach two hinges per door. The holes are piloted. Then, insert the hinges into the hinge plates inside the cabinet. Connect with screws.

Step 8.) Attach the door pulls with the screws included. Insert shallow & deep covers over cam lock holes. Deep covers are for interior cams, shallow are for the back panel cams.

Step 9.) Once you have the cabinet in the place you intend to use it, it will be time to adjust the hinges to align the doors. Using your screwdriver, turn the set screw on the hinge to adjust the depth and the screws on the hinge plate to move the door up/down. See diagram above.

Step 10.) Your last step is to insert the shallow & deep covers over the cam locks and to attach the plunger lock and lock core. Locate the pre-drilled notch on the underside of the Top Surface. Attach plunger lock so it inserts into the notch when pushed in. Attach the lock core with four screws provided.

Questions? Please call 1-800-443-5117.

Customer Service available 8:30 - 5:00 Central Time, Monday - Friday



2, 3 & 4 Drawer Lateral File Assembly Instructions

Applies towards:

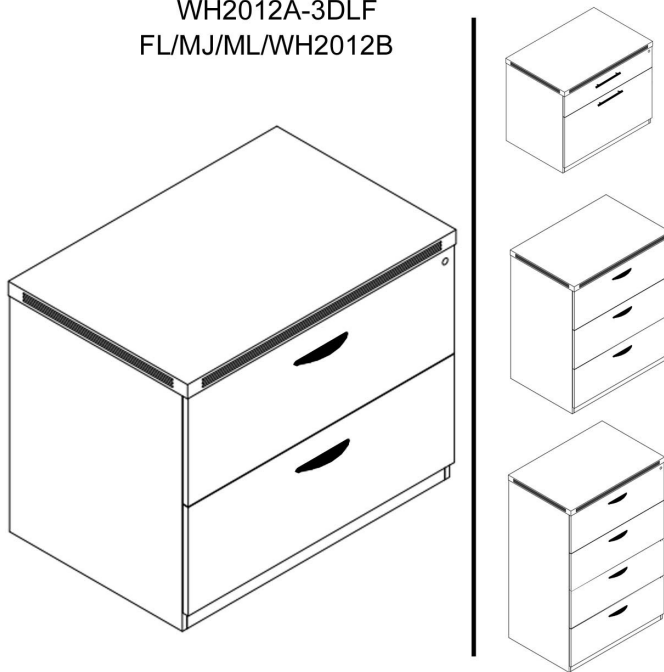
BK/FL/MJ/ML/WH2012
 WH2012A
 LF3622-MWAL
 LF3622-WH
 WH2012A-3DLF
 FL/MJ/ML/WH2012B

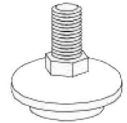

List of Hardware:

| Part | Part |
|---|--|
|  Drawer Pull Screw 2 per drawer pull |  Drawer Pull 1 per drawer |
|  1 set of keys |  4 Leveling Glides |

- 1.) Install 4 leveling glides. Keep the front two leveling glides 1/4" taller than the back back two, which means your file will be slightly tilted back. This is the proper way to level a lateral file cabinet. It keeps any unlocked file drawers from creeping open and distributes the weight more evenly.
- 2.) Use the screws to attach drawer pulls.

Questions? Please call 1-800-443-5117.
 Customer Service available 8:30 - 5:00 Central Time, Monday - Friday

5-Shelf Bookcase Assembly Instructions

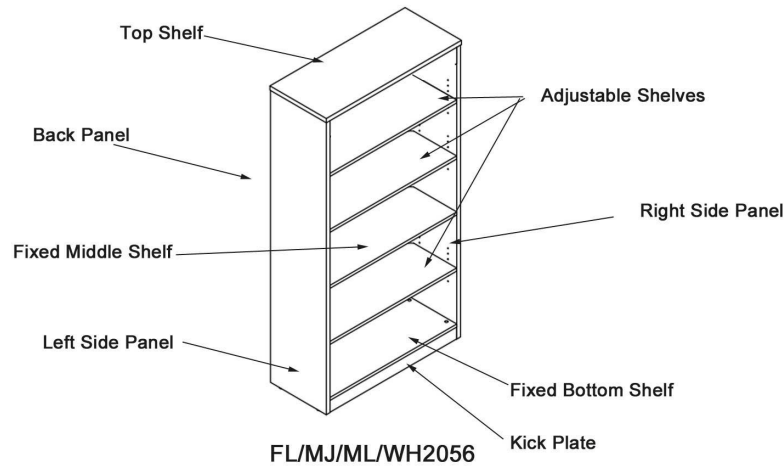

List of Hardware:

| Part | Part |
|---|---|
|  Wood Dowel |  Shallow Cover |
|  Cam Pin & Lock Set |  Deep Cover |
|  Shelf Pin |  Leveling Glide |

- 1.) Attach Kick Plate to Bottom Shelf using the cam locks and pins. Once connected, twist cam locks with your screwdriver to secure the connection.
- 2.) Next, insert all dowels, cam locks and cam pins into the Back Panel. Attach Middle Fixed Shelf and Bottom Fixed Shelf with attached Kick Plate.
- 3.) Attach Left & Right Side Panels in same method.
- 4.) Now, insert the four leveling glides into the bottom of the bookcase.
- 5.) Attach the Top Shelf to the rest of the bookcase.
- 6.) With a helper, carefully turn the bookcase upright.
- 7.) Insert Shallow & Deep Covers over the cam locks.
- 8.) The last step is to insert the shelf pins into the predrilled holes along the inside of the Left & Right side panels. Then set the adjustable shelves inside.

Tools Needed:

- Phillips Screwdriver
- A Helper

Special Note:

Location & number of cam pin, cam lock and dowel holes may vary.

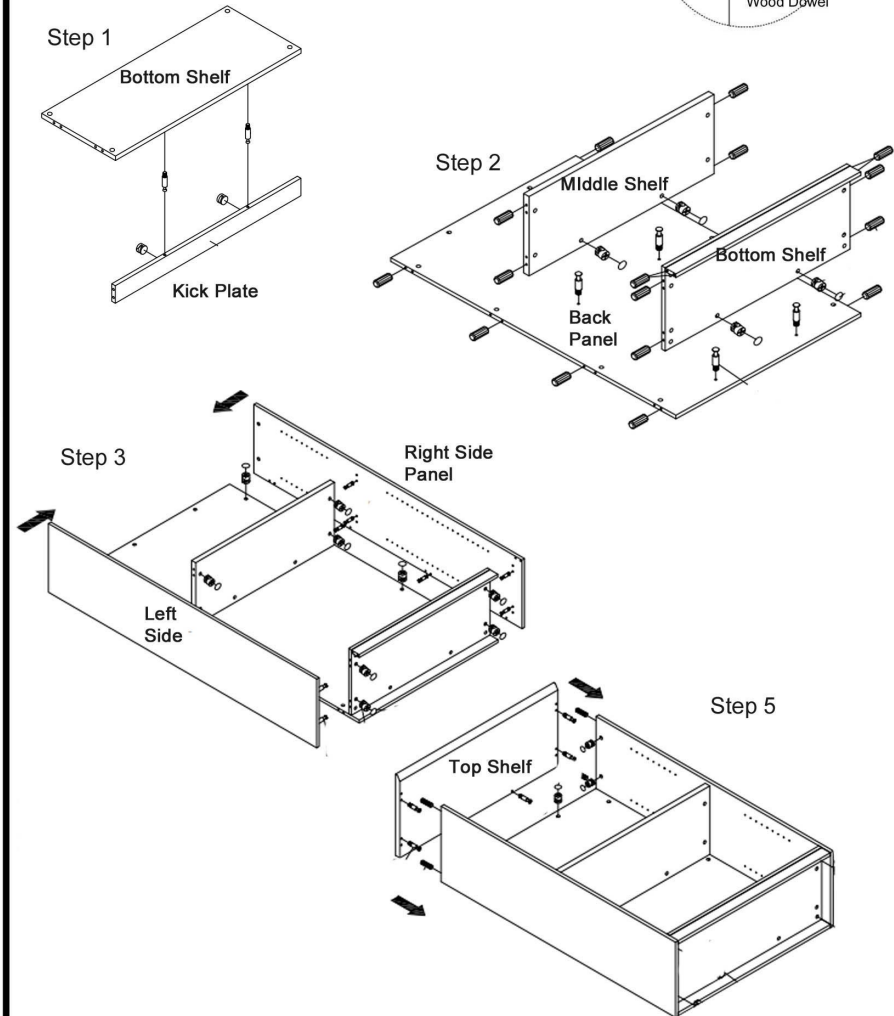
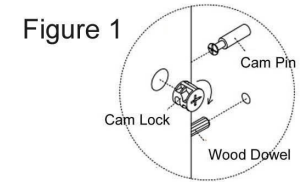

Questions? Please call 1-800-443-5117.
Customer Service available 8:30 - 5:00 Central Time, Monday - Friday

5-Shelf Bookcase w/Doors Assembly Instructions

MJ2096

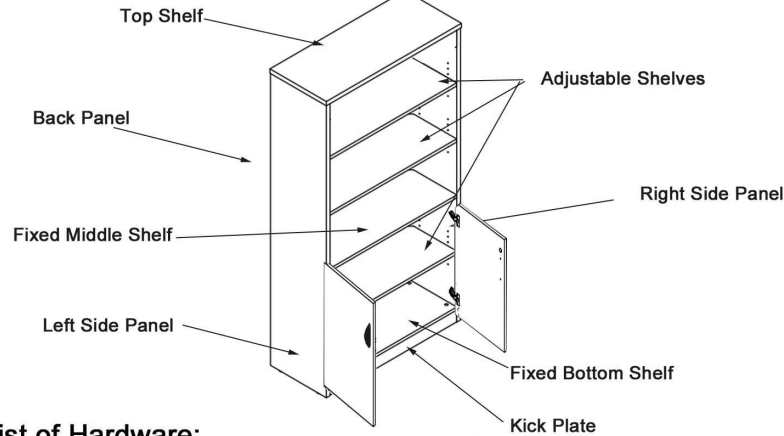

List of Hardware:

| | |
|---|---|
|  Wood Dowel |  Shallow Cover |
|  Cam Pin & Lock Set |  Deep Cover |
|  Shelf Pin |  Leveling Glide |
|  Hinge Plate |  Hinge |
|  Door Pull & Screws |  Set of Keys |

Tools Needed:

- Phillips Screwdriver
- A Helper

- 1.) Attach Kick Plate to Bottom Shelf using the cam locks and pins. Once connected, twist cam locks with your screwdriver to secure the connection.
- 2.) Next, insert all dowels, cam locks and cam pins into the Back Panel. Attach Middle Fixed Shelf and Bottom Fixed Shelf with attached Kick Plate.
- 3.) Attach Left & Right Side Panels in same method.
- 4.) Now, insert the four leveling glides into the bottom of the bookcase.
- 5.) Attach the Top Shelf to the rest of the bookcase.
- 6.) With a helper, carefully turn the bookcase upright.
- 7.) Attach doors with the hinges provided. You will need to adjust the hinges to level the doors (Figure 2). Attach door pulls with screws provided.
- 8.) Insert Shallow & Deep Covers over the cam locks.
- 9.) The last step is to insert the shelf pins into the predrilled holes along the inside of the Left & Right side panels. Then set the adjustable shelves inside.

Special Note:

Location & number of cam pin, cam lock and dowel holes may vary.

Figure 1

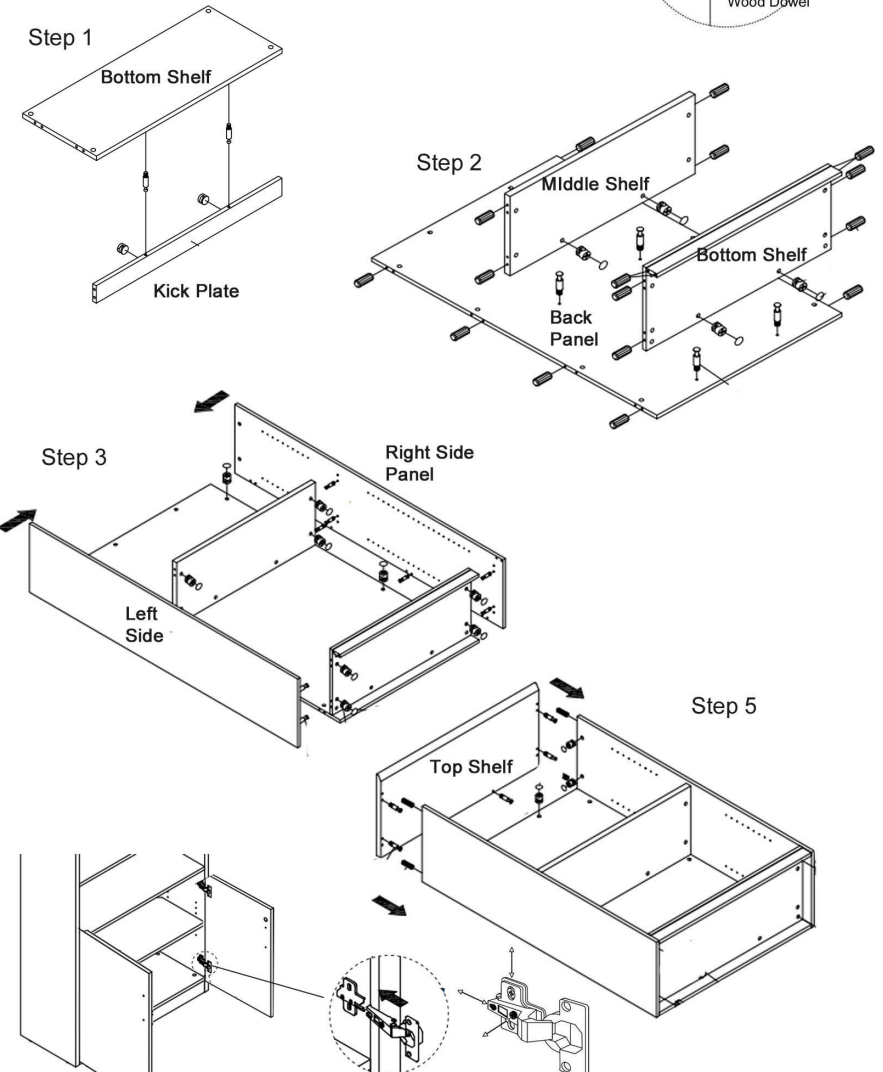
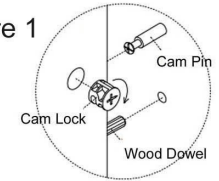

Questions? Please call 1-800-443-5117.

Customer Service available 8:30 - 5:00 Central Time, Monday - Friday

