

Glass Front Reception Desk Assembly Instructions



List of Hardware:

Qty 6  Wood Dowel	1 Sheet  Sticker Covers
Qty 24  Cam Pin	Qty 6  Leveling Glide
Qty 30  Cam Lock	Qty 2  Grommet
Qty 4  Mounting Discs/ Dowels for Glass Front Panel	Qty 8  Cam Pins for Glass Counter

Tools Needed:
 -Phillips Screwdriver
 - A helper!

- 1.) Assemble on carpet or cardboard to protect parts during assembly. Assembly will require 2 people for safety.
- 2.) Start by laying down both laminate Front Panels. Insert Cam Pins and Leveling Glides.
- 3.) Next, locate the Spacers and insert Dowels and Cam Locks. Using a screwdriver, attach the Spacers to the Front Panels by lining up the holes, inserting the Cam Pins into the Cam Locks and twisting the Cam Locks until locked.
- 4.) Next, with a helper, carefully set the Glass Front Panel, smooth side down, on the Spacers as shown. Line up the holes on both pieces.
- 5.) Insert the mounting discs through the glass and into the spacers. Twist to screw in and secure. **MAKE SURE YOUR DESK IS LAYING FLAT ON THE GROUND FOR THIS STEP!** Aligning the holes will be much easier.



- 6.) Locate the Desk Top. Your desk has two height settings for the Desk Top surface: 29"H for seated height and 35"H for standing height. Insert all of the hardware into the holes of the Desk Top and insert the Desktop into the Front Panels and Spaces at your preferred height. **PARTIALLY TIGHTEN ONLY!! DO NOT FULLY TIGHTEN YET!!** Leave yourself wiggle room.
- 7.) Next, locate both Side Panels. Insert all hardware and attach one side like shown. Then, the other side. **NOW**, you can fully tighten all of the cams on the Desk Top and Side Panels. With a helper, turn the desk upright.
- 8.) Locate the Glass Counter Next. It will have metal discs already adhered to the glass. Turn the glass disc side up and insert one cam pin per disc. Then, turn the glass disc side down, line up the pins with the holes in the top of the desk and insert. Fully tighten cam locks.
- 9.) Lastly, insert grommets and place caps over any exposed cam lock holes.

Questions? Please call 1-800-443-5117.





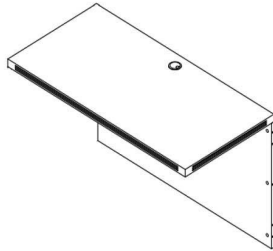





Customer Service available 8:30 - 5:00 Central Time, Monday - Friday

Reversible Bridge Assembly Instructions



Applies to:
BK/CH/FL/MJ/ML/WH2070

List of Hardware:

Part	Part	Part
		
Wood Dowel	Shallow Cover	Worksurface Bracket
		
Cam Pin	Deep Cover	Side Panel Brackets (2)
		
Cam Lock	Grommet	M6 Screw
		
Wood Screw		Leveling Glide

Tools Needed:

- Phillips Screwdriver
- Power Screwdriver
- A Helper

- 1.) Assemble on carpet or cardboard to protect parts during assembly. Assembly will require 2 people for safety.
- 2.) Insert all wood dowels, cam pins and cam locks on the Desktop and Side Panel. Then, connect the two panels together by lining up the holes with the dowels & pins. Insert cam pins into holes that align with cam locks. Twist cam locks with a Phillips Screwdriver to secure the connection
- 3.) The next step is to attach the bridge between your desks. Locate the 2 Worksurface brackets (they may already be attached on the ends of the Desktop. If not, use the M6 Machine Screws to attach, centered over the edges of the Desktop like shown in drawing.)

Special Note:

Location & number of cam pin, cam lock and dowel holes may vary.

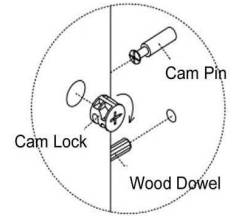

Step 5: Offset Bracket

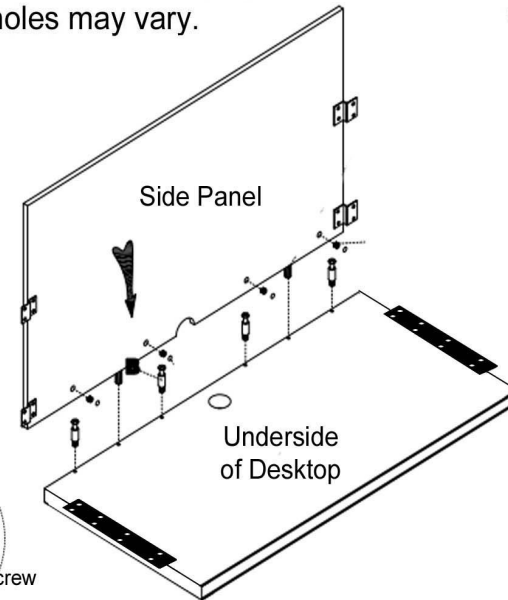
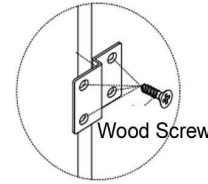

Left Hand Bridge

Right Hand Bridge

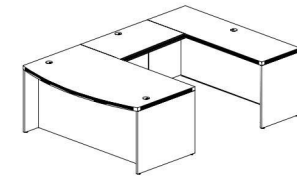
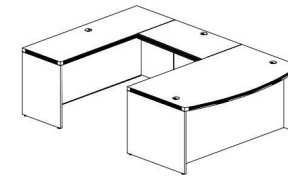

- 4.) Determine if the bridge will go on the left or right side of your desk. With a helper, have one person hold the bridge steady while the other person attaches the Worksurface Brackets to the undersides of the front desk & back credenza.
- 5.) Once installed & leveled, use the wood screws to install the offset side panel brackets. This will further secure the side panel, but is an optional step. A power screwdriver is helpful.
- 6.) Lastly, insert the grommet into the desktop and use the caps provided to cover the cam locks.

Questions? Please call 1-800-443-5117.

Customer Service available 8:30 - 5:00 Central Time, Monday - Friday

Desk/Credenza Shell Assembly Instructions

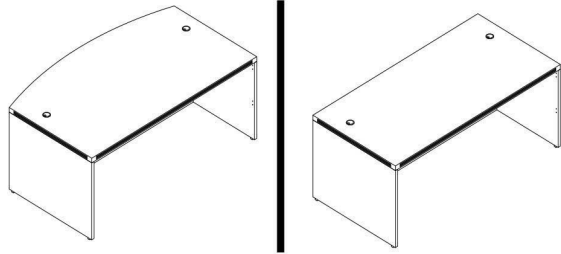

Applies to:

(BK/CH/MJ/ML/MWAL/WH) 2001/2002/2043/2089/3624/7124

List of Hardware:

Part	Part
 Wood Dowel	 Cap
 Cam Pin	 Leveling Glide
 Cam Lock	 Grommet

Tools Needed:

- Phillips Screwdriver
- A helper!

- 1.) Assemble on carpet or cardboard to protect parts during assembly. Assembly will require 2 people for safety.
- 2.) Locate left & right side panels. Screw in the leveling glides by hand. Then, insert wood dowels & cam pins. The wood dowels fit into the slightly larger holes, compared to the cam pin holes
- 3.) Locate front panel and insert all cam locks on the left & right sides. Then, align one of the side panels and connect the panel by inserting the cam pins into the cam locks and the dowels into the corresponding holes. (see diagram on next page). Twist the cam locks with a Phillips Screwdriver to secure.

Special Note:

Location & number of cam pin, cam lock and dowel holes may vary.

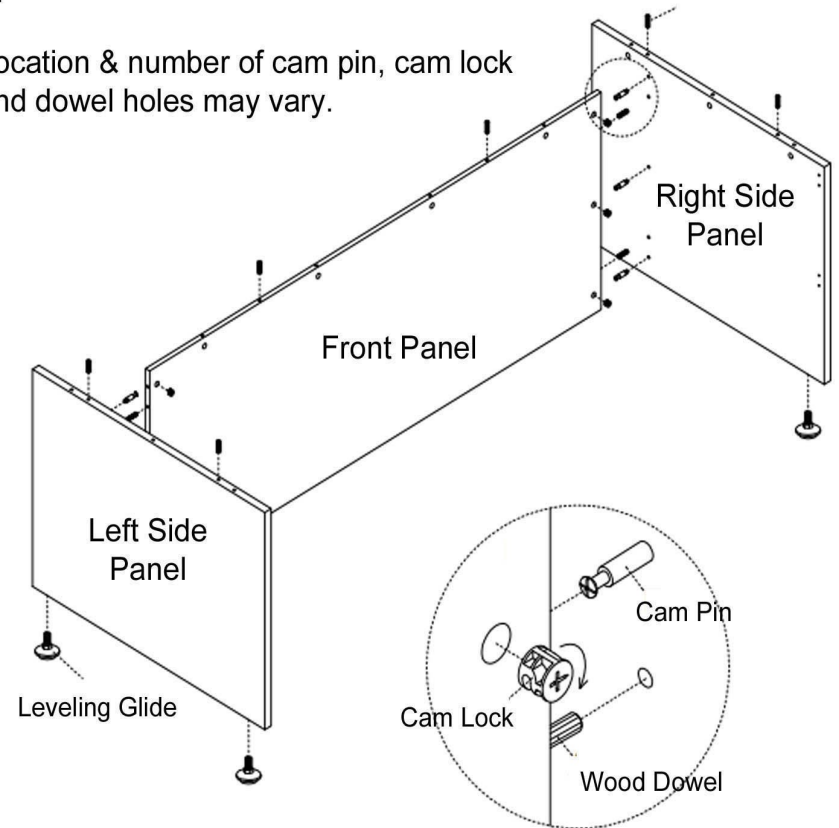

- 4.) Next, insert all cam pins, dowels and cam locks on the top edges of the side panels and front panels. Locate the desktop and with a helper, carefully set the desktop on top of the assembly shown above. Twist cam locks to secure the connection.
- 5.) Your last step is to insert the grommet(s) provided into the desktop. Cover the cam locks with the caps provided.

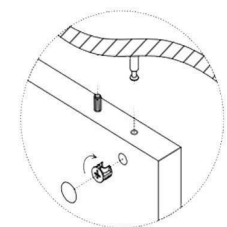
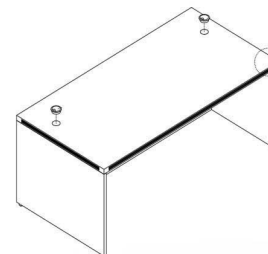

Questions? Please call 1-800-443-5117.

Customer Service available 8:30 - 5:00 Central Time, Monday - Friday



Box/Box/File Desk Pedestal Assembly Instructions

Applies towards:

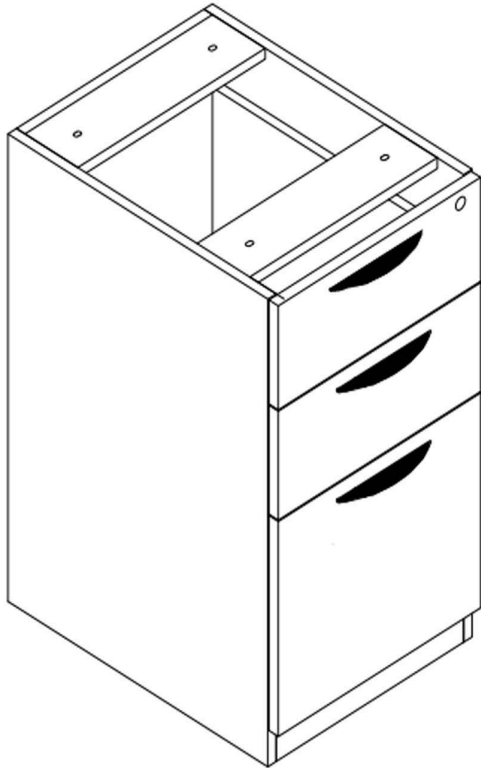
BK/CH/FL/MJ/ML/WH2066

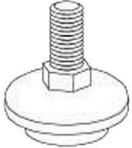

List of Hardware:

Part	Part
 4 Large Bolts	 3 Drawer Pulls with screws
 1 set of keys	 4 Leveling Glides

- 1.) Install 4 leveling glides.
- 2.) Use the screws to attach drawer pulls.
- 3.) To install under desk, remove the top box drawer (or top two box drawers) by locating the black tabs inside of the left & right drawer slides. Push down on one and push up on the other. This will release the drawer from the slides. Use 4 large bolts to connect to threaded holes on underside of desk. Once done, simply insert drawers back into the slides. They will snap in place.

Questions? Please call 1-800-443-5117.

Customer Service available 8:30 - 5:00 Central Time, Monday - Friday



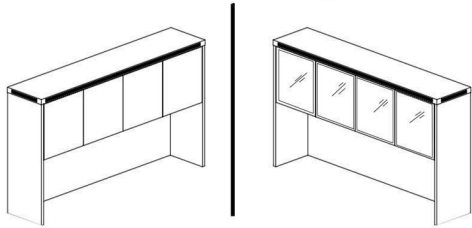





4-Door Hutch Assembly Instructions



Applies to:
BK/CH/FL/MJ/ML/WH2044
MJ2025-CHL

Questions? Please call 1-800-443-5117.
Customer Service available 8:30 - 5:00 Central Time, Monday - Friday

List of Hardware:

Part	Part	Part
		Qty 4 
		Qty 4 
		Qty 8 

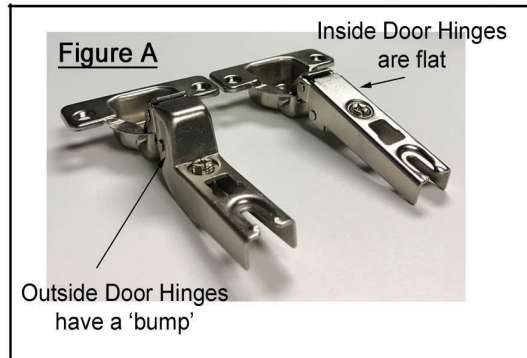

1.) Locate the Back Panel, Left & Right Side Panels and Center Shelf. Insert all wooden dowels, cam pins and cam locks. Connect Back Panel to the Center Shelf. Then connect the Left Side Panel, then Right Side Panel. Once all panels are connected, use your screwdriver to twist the cam locks to secure the connections.

2.) Connect the Middle Support Panel in same method.

3.) Attach Top Surface in same method.

4.) Attach all 8 Hinge Plates to the inside walls of the hutch. Use two per door. The holes are piloted. **DO NOT TIGHTEN DOWN THE SCREWS ALL OF THE WAY. LEAVE WIGGLE ROOM!**

Tools Needed:

- Phillips Screwdriver
- A Helper

Special Note:

Location & number of cam pin, cam lock and dowel holes may vary.

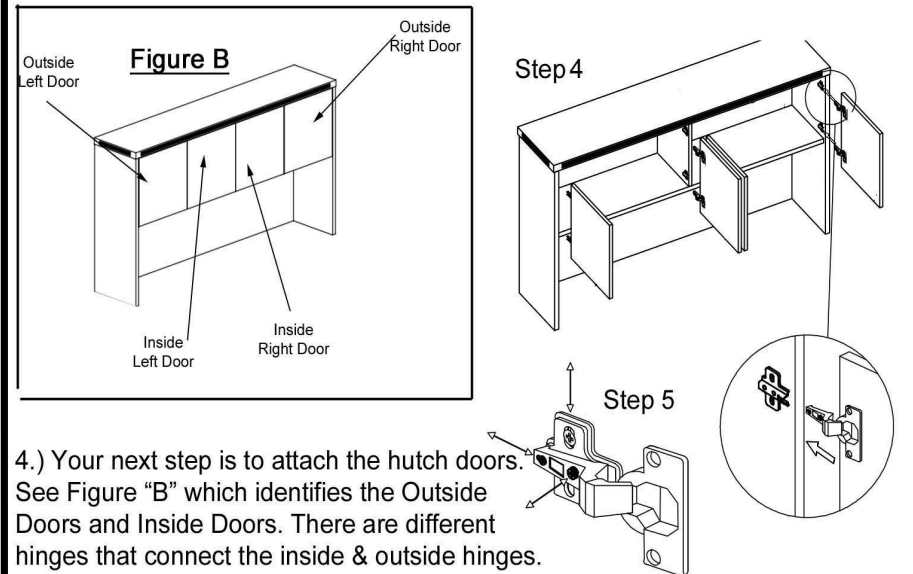
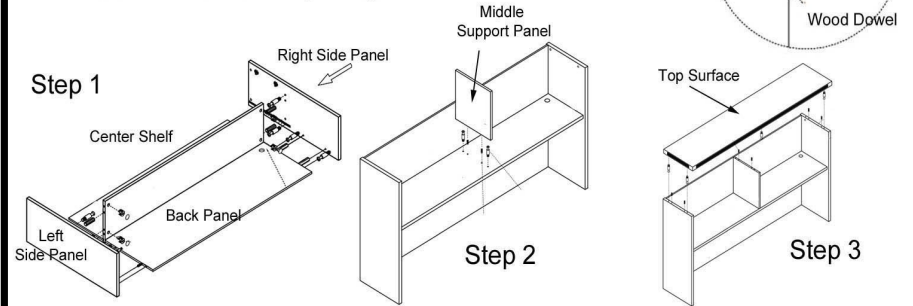

4.) Your next step is to attach the hutch doors. See Figure "B" which identifies the Outside Doors and Inside Doors. There are different hinges that connect the inside & outside hinges. See Figure "A" to help identify. Attach two hinges per door. Use the hinges with the 'bump' on the Outside Left & Right Doors and the flat hinges on the Inside Left & Right Doors. The holes are piloted. Use the screws provided. Once the hinges are attached, slide the hinges over the Hinge Brackets, fitting the screw head of the Hinge Bracket in the slot of the Hinge. Once fitted, slightly tighten the set screw. Now, set your hutch on your desk. Use the double-sided tape to securely adhere to desktop.

5.) Next, it is time to adjust the doors so that they properly align. Using your screwdriver, turn the Set Screw on the hinge to adjust the depth and the screws on the hinge plate to move the door up/down.

6.) Last step is to install Cam Lock Caps and Grommet cover.

Video on Hinge Door Adjustment available at link:
<http://www.modernofficefurniture.com/office-furniture-assembly-instructions.html>

"How to Adjust Hinges on 4-Door Hutch"