

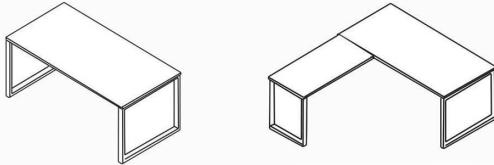

TrendSpaces Desk Series
Desk/Credenza Assembly Instructions
L-Desk Assembly Instructions
(PLT2472, PLT3066, PLT3672 & PLT2448
PLTLEGD2472, PLTLEGD30, PLTLEGD36 & PLTLEGD24)



List of Hardware:

Part	Part
 Leveling Glide	 3/4" Bolt
 2" Bolt	 Bracket (for return desks only)
 Grommet	

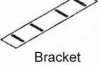
Tools Needed:

- Allen Wrench included (to connect bolts)
- A Helper

Desk or Credenza:

- 1.) Assemble on carpet or cardboard to protect parts during assembly. Assembly will require 2 people for safety.
- 2.) Screw in leveling glides on all frames.
- 3.) Next, assemble metal desk frame by attaching the cross beam to the left & right side legs. The bolts for the cross beam are already in the legs. Just back out, place beam and screw back in. Use 16 of the 3/4" bolts total for this step, 8 for each side.
- 4.) Use a total of 4 of the 2" Bolts to attach the metal frame to the worksurface. Once connected, insert the grommets.

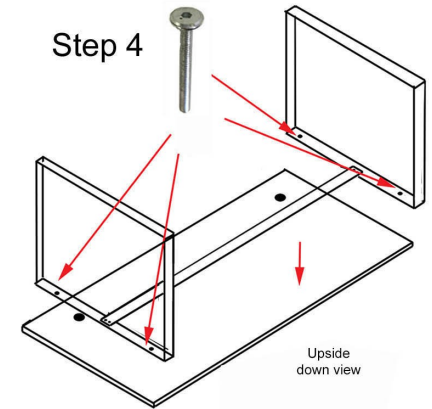
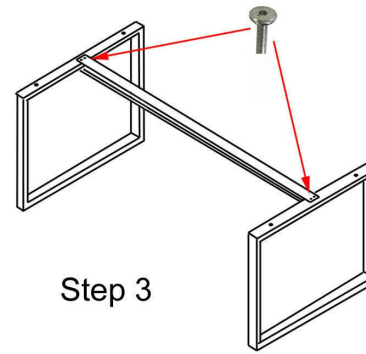

Return Desk:

- 5.) If you purchased an L-desk, attach the return desk end leg to the desktop with 2 more 2" Bolts, that are taped to the leg.
- 6.) The mounting bracket will already be installed on the return desktop. Use a total of 6 of the 3/4" Bolts to attach the bracket to the underside of the two worksurfaces.

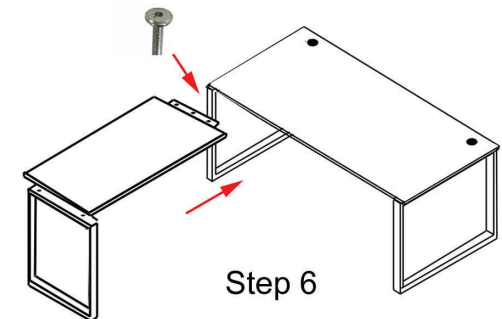
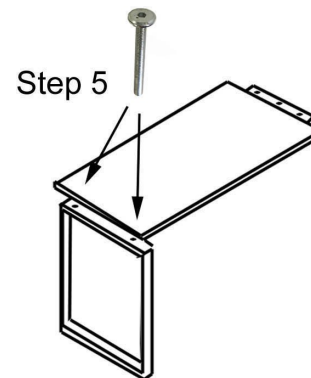



Questions? Please call 1-800-443-5117.
Customer Service available 8:30 - 5:00 Central Time, Monday - Friday

Y11128 - Steel Mobile Box/Box/File Assembly Instructions (MMP-SLV)



List of Hardware:

Part	Part
	
	Keys

- 1.) Install 5 casters in by hand. They snap into place.
- 2.) Insert keys into lock.

Questions? Please call 1-800-443-5117.
Customer Service available 8:30 - 5:00 Central Time, Monday - Friday

Mounting Instructions for
63"W & 71"W Acrylic Dividers
Y11135, Y11136, Y11137 & Y11138
(ACM1600, ACM1800, CLIP1 and CLIP2)



Single Sided Bracket
(CLIP1)



Double Sided Bracket
(CLIP2)

Hardware Included:

- Allen Wrench

1.) Each panel will need two clips. Move leveling screw to the hole closest to the square edge of the clip like shown below. Attach the clips to each panel BEFORE you attach the clips to the desktop.



IMPORTANT: If Clip Bracket is mounted to desktop first, the clamp portion for the panel will not tighten because of friction between the desktop and the sliding bracket.

2.) For best spacing and stability, attach brackets 1/4 of length from ends of panel. For 63" panels, this would be approx. 16" from panel ends. For 71" panels, this would be approximately 18" from panel ends.

3.) When using CLIP2/Double Sided Brackets between desktops, it is important to tighten the clamps to the desktops evenly so that the panel stands perfectly upright. If bracket to one desk is tightened more than the opposing bracket, the bracket and panel may lean slightly to that side.

4.) Once clips are installed on the desktop, tighten with allen wrench.



Finished View of CLIP1

Questions? Please call 1-800-443-5117.
Customer Service available 8:30 - 5:00 Central Time, Monday - Friday