

Peninsula Desk Assembly Instructions

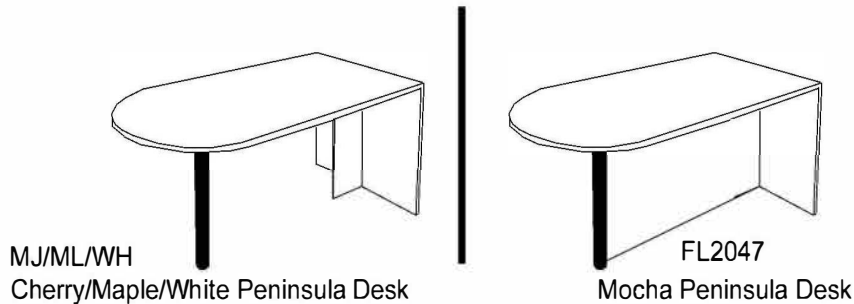

Applies to:
FL/MJ/ML/WH2047

List of Hardware:

Part	Part
 Wood Dowel	 Cap
 M6 Screw	 Leveling Glide
 Cam Lock & Pin Set	

Tools Needed:
-Phillips Screwdriver
- A helper!

- 1.) Assemble on carpet or cardboard to protect parts during assembly. Assembly will require 2 people for safety.
- 2.) Locate Post Leg. (You may need to tighten the connecting plate by tightening the screw inside the leg). Using the 4 M6 Machine Screws provided and screw the top of the leg into the underside of the peninsula desktop. The holes are piloted.
- 3.) Next, insert all dowels, cam pins and cam locks into the desktop, Side Panel and Support.
- 4a.) If you have a Cherry, Maple or White Peninsula desk, attach the Support and Side Panel together. Insert the dowels and cam pins into the corresponding holes and twist the cam locks with your screwdriver to secure. (Fig. 1)
- 4b) If you have a Mocha Peninsula Desk, Attach the Support to the Post leg and Desktop first.

Special Note:

Location & number of cam pin, cam lock and dowel holes may vary.

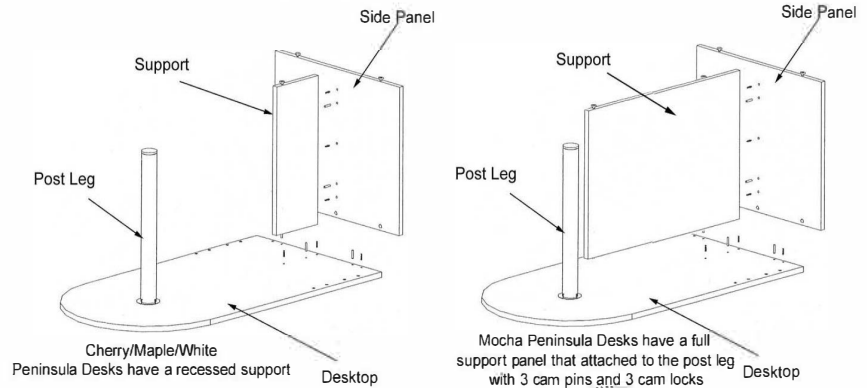
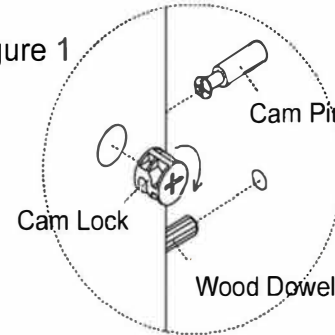

Figure 1



- 5a) If you have a Cherry, Maple or White Peninsula Desk, your next step will be to attach the Support/Side Panel assembly to the desktop using the same hardware method.
- 5b) If you have a Mocha Peninsula Desk, your next step will be to attach the Side Panel to the Support and Desktop.
- 6) Insert all Leveling Glides and with a helper, carefully turn the desk upright.
- 7) Once in place, cover all Cam Locks with the Caps provided.

Questions? Please call 1-800-443-5117.
Customer Service available 8:30 - 5:00 Central Time, Monday - Friday

Reversible Desk Return Assembly Instructions

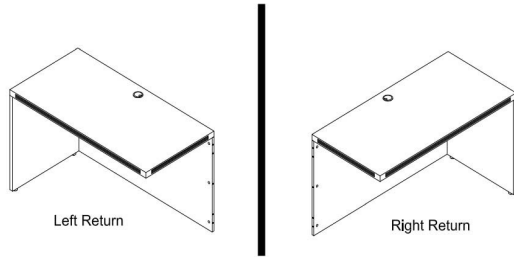

Applies to:
BK/FL/MJ/ML/WH 2045

List of Hardware:

Part	Part	Part
Wood Dowel	Shallow Cover	Worksurface Bracket
Cam Pin	Deep Cover	Side Panel Brackets (2)
Cam Lock	Grommet	M6 Screw
Wood Screw		Leveling Glide

Tools Needed:

- Phillips Screwdriver
- Power Screwdriver
- A Helper

- 1.) Assemble on carpet or cardboard to protect parts during assembly. Assembly will require 2 people for safety.
- 2.) Determine if the return will be left or right handed (see diagram next page). Locate Side Panel & End Panel and arrange like shown in drawing. Insert leveling glides, then insert all cam pins, cam locks and wood dowels. Then connect the panels by inserting the dowels into the holes on opposite panel and inserting cam pins into cam locks (see diagram). Then, twist the cam locks with a Phillips Screwdriver to secure connection.
- 3.) Next, locate the Desktop and insert hardware. Then, set the desktop on the lower assembly and twist cams to securely connect.

Special Note:

Location & number of cam pin, cam lock and dowel holes may vary.

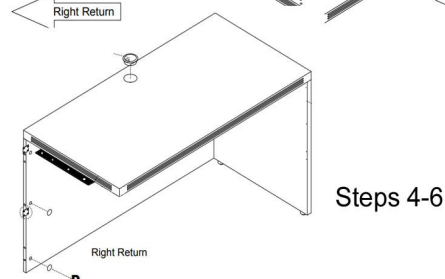
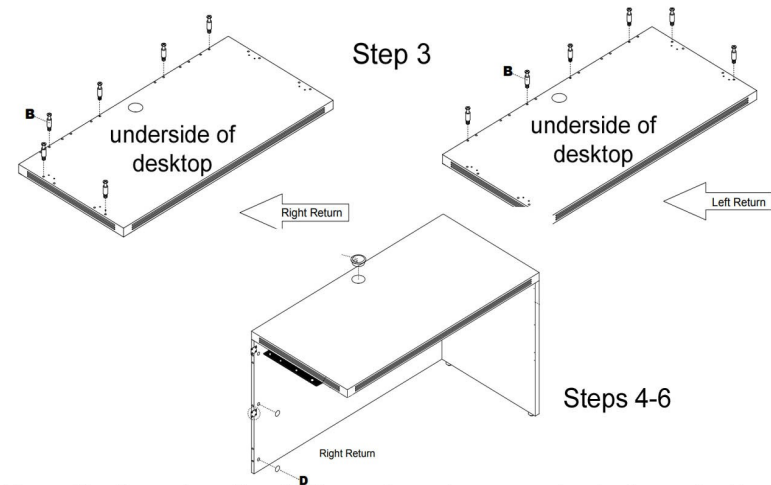
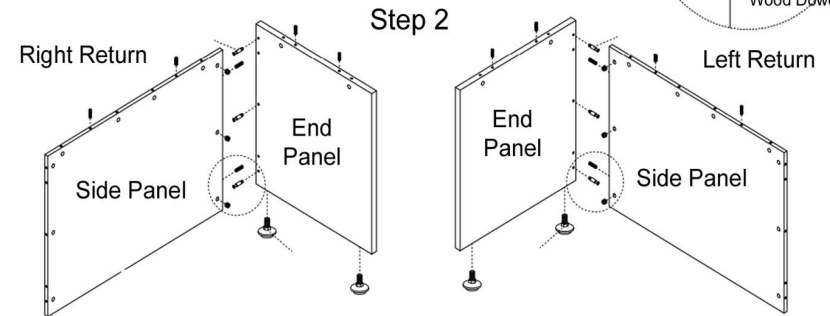
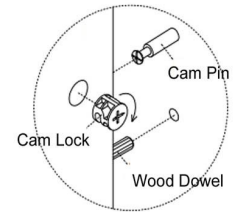

- 4.) Now it's time to attach the return to your desk. Locate the large flat bracket and M6 machine screws (it may be attached to the desktop already. If not, center the bracket over the edge and install 4 of the screws). With a helper, have one person hold the return desk stable while the other screws the machine screws into the desk.
- 5.) Once installed & leveled, use the wood screws to install the offset side panel brackets. This will further secure the side panel, but is an optional step. A power screwdriver is helpful.
- 6.) Lastly, insert the grommet into the desktop and use the caps provided to cover the cam locks.

Questions? Please call 1-800-443-5117.



Customer Service available 8:30 - 5:00 Central Time, Monday - Friday

Box/Box/File Desk Pedestal Assembly Instructions

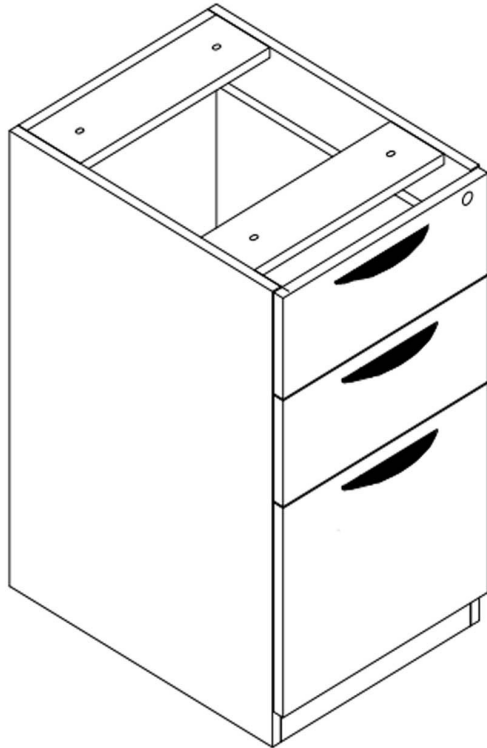
Applies towards:
BK/FL/MJ/ML/WH2066

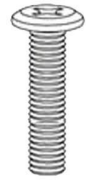

List of Hardware:

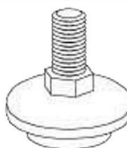
Part	Part
 4 Large Bolts	 3 Drawer Pulls with screws
 1 set of keys	 4 Leveling Glides

1.) Install 4 leveling glides. Keep the front two leveling glides 1/4" taller than the back back two, which means your file will be slightly tilted back. This is the proper way to level a lateral file cabinet. It keeps any unlocked file drawers from creeping open and distributes the weight more evenly.

2.) Use the screws to attach drawer pulls.

3.) To install under desk, remove the top box drawer (or top two box drawers) by locating the black tabs inside of the left & right drawer slides. Push down on one and push up on the other. This will release the drawer from the slides. Use 4 large bolts to connect to threaded holes on underside of desk. Once down, simply insert drawers back into the slides. They will snap in place.

Questions? Please call 1-800-443-5117.

Customer Service available 8:30 - 5:00 Central Time, Monday - Friday