

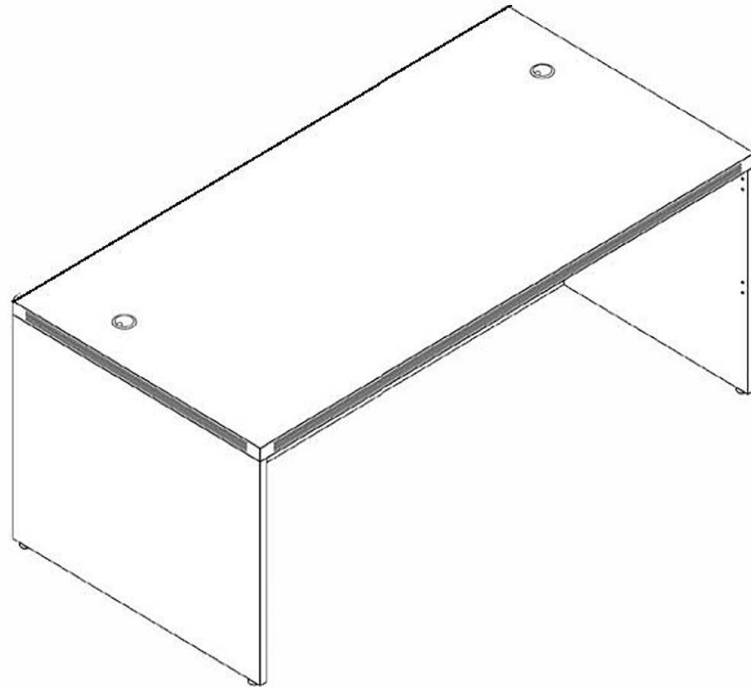

www.modernofficefurniture.com







Desk/Credenza Shell

MJ/FL/ML/WH/BK
2001/2002/2C43/2089/3624/7124

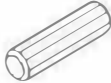

ASSEMBLY INSTRUCTIONS

PARTS LIST

Part	Part
 Wood Dowel	 Cap
 Cam Pin	 Leveling Glide
 Cam Lock	 Grommet
 Screw	 L-Bracket

1.) Assemble on a smooth, carpeted floor to prevent scratches or damage. Assembly will require 2 people for safety.

2.) Screw 2 leveling glides in completely on both side panels. When completed, the glides can be adjusted outward to level the desk on uneven floors.

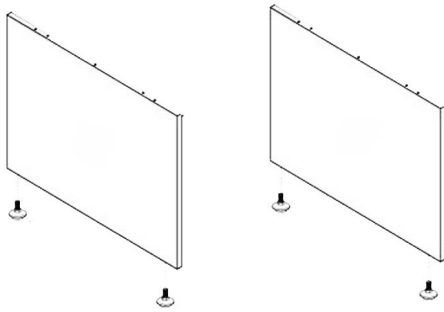

3.) Next, take out the front panel and position with side panels like shown on page 3.

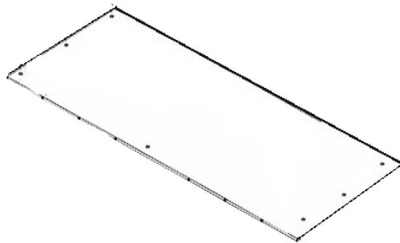

4.) Insert wood dowels into large holes and cam pins into smaller holes. Align the panels together and attach using a Phillips Screwdriver to twist the cam locks to secure.

(Number of holes in diagram may vary from actual desk)

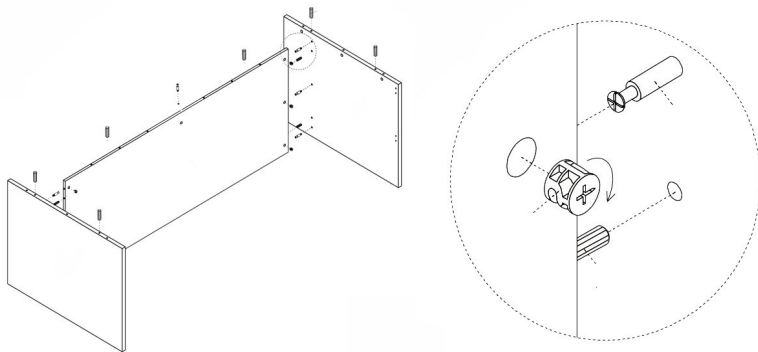

5.) Lower Desktop onto front and side panels, making sure to align holes. Twist any remaining cam locks to secure.

6.) L-brackets and screws are optional and can be placed anywhere underneath the desktop for additional strength. Screws are self-drilling

7.) Install grommets. Note: Credenza Shells have only 1 grommet.

8.) Lastly, pop in any cam lock covers over the silver cam locks.

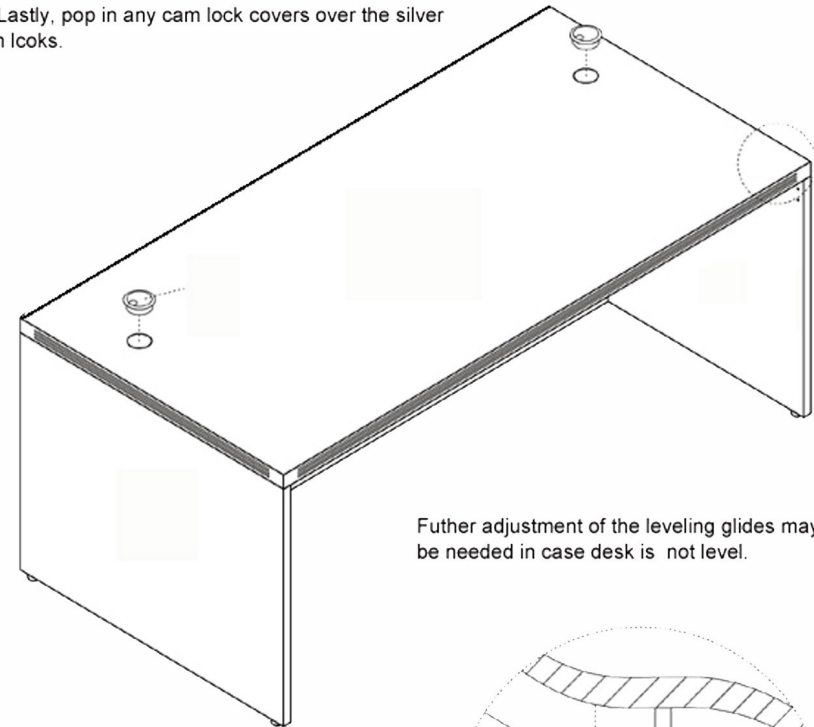

Further adjustment of the leveling glides may be needed in case desk is not level.

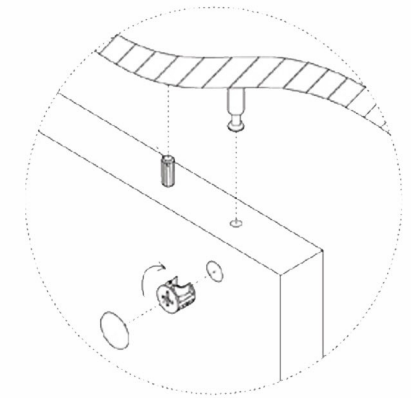

Questions? Please call 1-800-443-5117.
Customer Service available 8:30 - 5:00 Central Time, Monday - Friday



Box/Box/File Pedestal

MJ/FL/ML/WH2066



Install Instructions

PARTS LIST

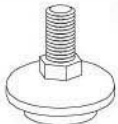
Part	Part
 Bolt	 Drawer Pull & Screws
 Keys	 Leveling Glide

- 1) Install 4 leveling glides and level the file
- 2.) Install drawer pulls with screws provided.

To attached under desk (optional):

- 1.) Remove 1 or 2 of the box drawers by locating the black tabs in the left & right side of the drawer. Pull up on one tab, push down on the other to unlock from the track and remove drawer.
- 2.) Use 4 bolts provided to go through the top of the file into the threaded holes on the underside of the desk.



www.modernofficefurniture.com

Y11927, Y11928, Y11929,
Y11930 and Y11931 Reception
Desks with Reception Cap

White Reception Cap Assembly Instructions









CAP66 & CAP72



Tools Required:

- Phillips Screwdriver
- or
- Power Screwdriver (set on lightest setting to avoid stripping of screws)

Hardware Included:

<p>Cam Lock</p>  <p>A</p> <p>QTY 32</p>	<p>Cam Pin</p>  <p>B</p> <p>QTY 32</p>	<p>Wood Dowel</p>  <p>C</p> <p>QTY 8</p>	<p>Spacer Cylinder for Rec. Cap</p>  <p>D</p> <p>QTY 4</p>
<p>1" Threaded Support for Glass Counter</p>  <p>E</p> <p>QTY 8</p>	<p>Threaded Cylinder Bolt</p>  <p>F</p> <p>QTY 8</p>	<p>Threaded Cylinder Cap</p>  <p>G</p> <p>QTY 8</p>	<p>Light Fixture Kit</p> 

Questions? Please call 1-800-443-5117.

Customer Service available 8:30 - 5:00 Central Time, Monday - Friday

Step 1) Uncarton and lay out components on a smooth carpeted surface to protect from scratching.

Step 2) Screw in 6 (B) Cam Pins into 3/4" thick Riser Shelf.

Step 2



Step 3



Step 4



Step 3) Attach 3 Shelf Dividers using two (A) Cam Locks each.

Step 4) Attach Left and Right Sides using two (A) Cam Locks each.
Set aside until Step 7.

Step 5) Prepare Front Panel by first attaching six (B) Cam Pins. Larger holes next to cam pin holes will be used for (C) Wood Dowels to add extra support. Next, screw in 4 (D) Spacer Cylinders with threaded ends into metal inserts in Front Panel. These will serve as spacers between the front side panels of the desk and the Front Panel of the reception desk allowing the electrical cable of the light to run over desk top and back down into desk through desk top cable grommet.



Step 6) Prepare and attach light fixture. Plug cord into end of light fixture. Attach two clips/brackets to Front Panel with two wood screws provided into predrilled holes of Front Panel. Light fixture will then clip onto brackets.

Step 6



Step 7

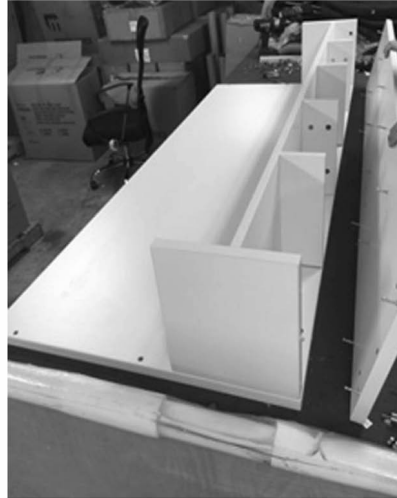

Step 7) Mount frame assembled in steps 2-4 onto Front Panel using six (A) Cam Locks. Now mount 1" thick Riser Top using eight (A) Cam Locks.

Step 8) Main reception cap is now complete and ready to mount to desk before final step of attaching glass. Peel 2-sided tape from underside of Left and Right Sides and carefully position on desktop. Light cable should be routed up and over desktop before adhering reception cap so that cable is not exposed from visitor's side of desk. Cable will then route through desk top cable grommets and down to floor under desk.

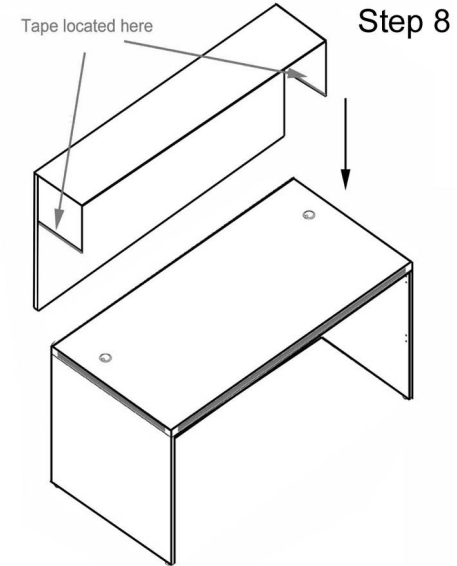

Step 9) Once reception cap is positioned and adhered, attach Glass Counter using eight (G) Threaded Small Top Cylinder Caps, eight (E) 1" Support Cylinders and eight (F) Threaded Cylinder Bolts. These can be tightened down by hand.







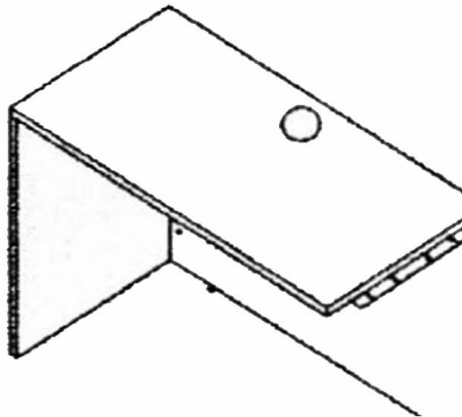



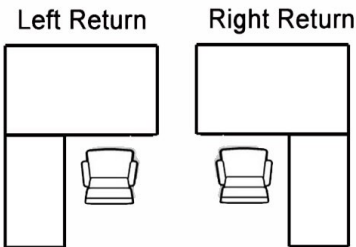



Questions? Please call 1-800-443-5117.
Customer Service available 8:30 - 5:00 Central Time, Monday - Friday

Reversible Desk Return BK/FL/MJ/ML/WH2045



ASSEMBLY INSTRUCTIONS



Part	Part	Part
 Wood Dowel	 Shallow Cover	 Worksurface Bracket
 Cam Pin	 Deep Cover	 Side Panel Brackets (2)
 Cam Lock	 Grommet	 M6 Screw
 Wood Screw	 L-Bracket	 Leveling Glide

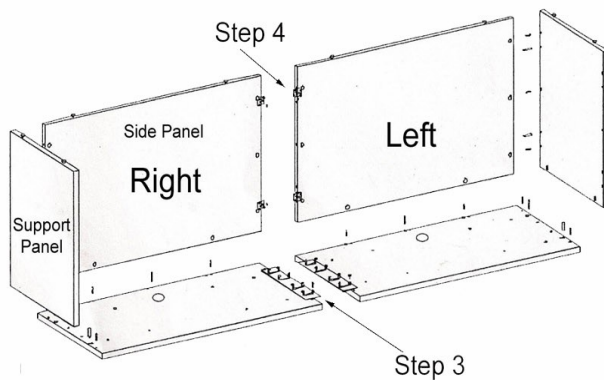
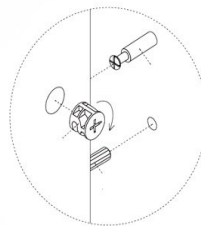

Assemble upside down in carpeted area

Step 1:
Determine if return desk is to be Left or Right.

Step 2:
Attach Side Panel and Support Panel using dowels, cam locks and cam pins provided.

Step 3:
Using M6 Screws, attach flat bracket to edge of return as shown in the photo, centering it over the edge.

Step 4:
Using wood screws provided, attach both side panel offset brackets to the side panel as shown.

Step 5:
Screw in floor glides.

Step 6:
Carefully turn over return desk and attach to main desk using M6 screws, connecting other side of flat bracket to underside of main desk

Step 7:
Insert grommet and covers. Shallow covers go over cams on side panel, deep covers go over cams on support panel, since those are more inset.

Questions? Please call 1-800-443-5117.
Customer Service available 8:30 - 5:00 Central Time, Monday - Friday