

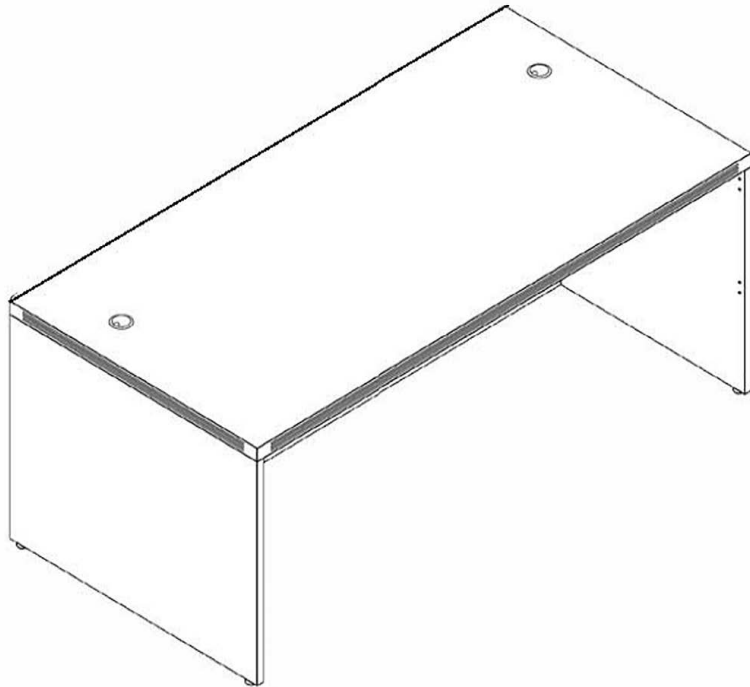

www.modernofficefurniture.com





Desk/Credenza Shell

MJ/FL/ML/WH/BK
2001/2002/2043/2089/3624/7124

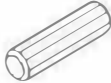

ASSEMBLY INSTRUCTIONS

PARTS LIST

Part	Part
 Wood Dowel	 Cap
 Cam Pin	 Leveling Glide
 Cam Lock	 Grommet
 Screw	 L-Bracket

1.) Assemble on a smooth, carpeted floor to prevent scratches or damage. Assembly will require 2 people for safety.

2.) Screw 2 leveling glides in completely on both side panels. When completed, the glides can be adjusted outward to level the desk on uneven floors.

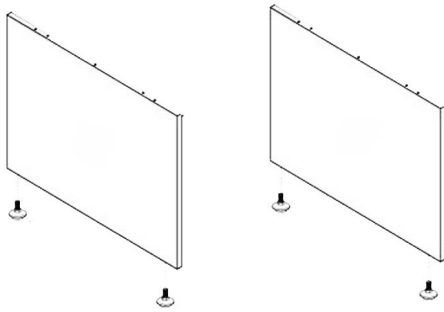

3.) Next, take out the front panel and position with side panels like shown on page 3.

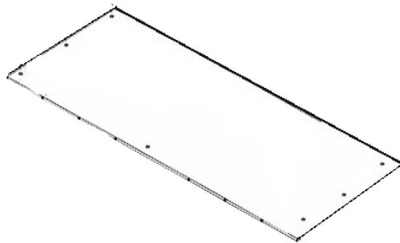

4.) Insert wood dowels into large holes and cam pins into smaller holes. Align the panels together and attach using a Phillips Screwdriver to twist the cam locks to secure.

(Number of holes in diagram may vary from actual desk)

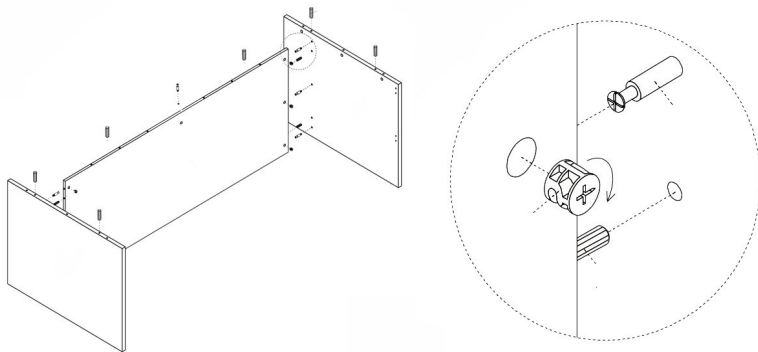

5.) Lower Desktop onto front and side panels, making sure to align holes. Twist any remaining cam locks to secure.

6.) L-brackets and screws are optional and can be placed anywhere underneath the desktop for additional strength. Screws are self-drilling

7.) Install grommets. Note: Credenza Shells have only 1 grommet.

8.) Lastly, pop in any cam lock covers over the silver cam locks.

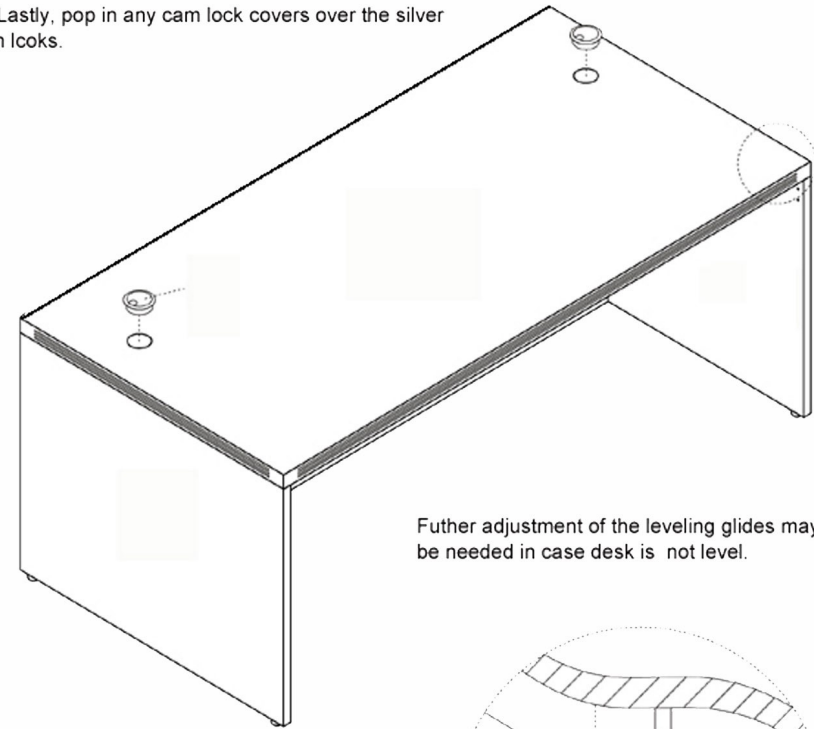

Further adjustment of the leveling glides may be needed in case desk is not level.

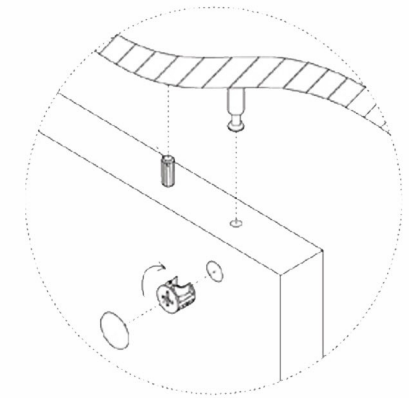

Questions? Please call 1-800-443-5117.
Customer Service available 8:30 - 5:00 Central Time, Monday - Friday



Box/Box/File Pedestal

MJ/FL/ML/WH2066



Install Instructions

PARTS LIST

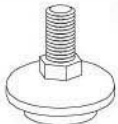
Part	Part
 Bolt	 Drawer Pull & Screws
 Keys	 Leveling Glide

- 1) Install 4 leveling glides and level the file
- 2.) Install drawer pulls with screws provided.

To attached under desk (optional):

- 1.) Remove 1 or 2 of the box drawers by locating the black tabs in the left & right side of the drawer. Pull up on one tab, push down on the other to unlock from the track and remove drawer.
- 2.) Use 4 bolts provided to go through the top of the file into the threaded holes on the underside of the desk.



Since 1978

www.modernofficefurniture.com

Y11927, Y11928, Y11929,
Y11930 and Y11931 Reception
Desks with Reception Cap

White Reception Cap Assembly Instructions









CAP66 & CAP72



Tools Required:

- Phillips Screwdriver
- or
- Power Screwdriver (set on lightest setting to avoid stripping of screws)

Hardware Included:

<p>Cam Lock</p>  <p>A</p> <p>QTY 32</p>	<p>Cam Pin</p>  <p>B</p> <p>QTY 32</p>	<p>Wood Dowel</p>  <p>C</p> <p>QTY 8</p>	<p>Spacer Cylinder for Rec. Cap</p>  <p>D</p> <p>QTY 4</p>
<p>1" Threaded Support for Glass Counter</p>  <p>E</p> <p>QTY 8</p>	<p>Threaded Cylinder Bolt</p>  <p>F</p> <p>QTY 8</p>	<p>Threaded Cylinder Cap</p>  <p>G</p> <p>QTY 8</p>	<p>Light Fixture Kit</p> 

Questions? Please call 1-800-443-5117.

Customer Service available 8:30 - 5:00 Central Time, Monday - Friday

Step 1) Uncarton and lay out components on a smooth carpeted surface to protect from scratching.

Step 2) Screw in 6 (B) Cam Pins into 3/4" thick Riser Shelf.

Step 2



Step 3



Step 4



Step 3) Attach 3 Shelf Dividers using two (A) Cam Locks each.

Step 4) Attach Left and Right Sides using two (A) Cam Locks each.
Set aside until Step 7.

Step 5) Prepare Front Panel by first attaching six (B) Cam Pins. Larger holes next to cam pin holes will be used for (C) Wood Dowels to add extra support. Next, screw in 4 (D) Spacer Cylinders with threaded ends into metal inserts in Front Panel. These will serve as spacers between the front side panels of the desk and the Front Panel of the reception desk allowing the electrical cable of the light to run over desk top and back down into desk through desk top cable grommet.



Step 6) Prepare and attach light fixture. Plug cord into end of light fixture. Attach two clips/brackets to Front Panel with two wood screws provided into predrilled holes of Front Panel. Light fixture will then clip onto brackets.

Step 6



Step 7

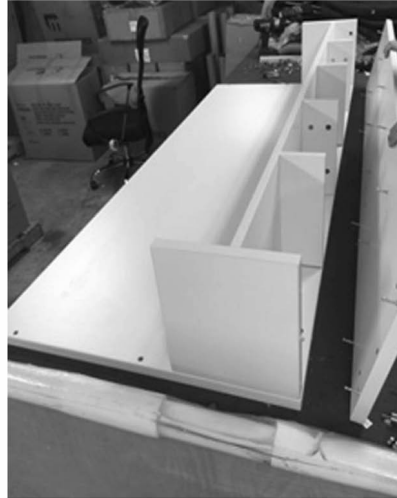

Step 7) Mount frame assembled in steps 2-4 onto Front Panel using six (A) Cam Locks. Now mount 1" thick Riser Top using eight (A) Cam Locks.

Step 8) Main reception cap is now complete and ready to mount to desk before final step of attaching glass. Peel 2-sided tape from underside of Left and Right Sides and carefully position on desktop. Light cable should be routed up and over desktop before adhering reception cap so that cable is not exposed from visitor's side of desk. Cable will then route through desk top cable grommets and down to floor under desk.

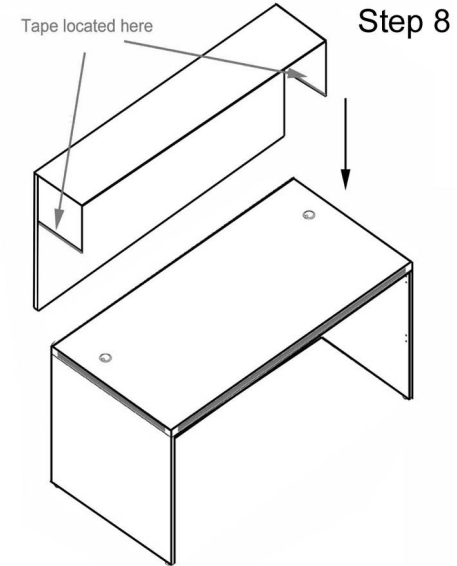

Step 9) Once reception cap is positioned and adhered, attach Glass Counter using eight (G) Threaded Small Top Cylinder Caps, eight (E) 1" Support Cylinders and eight (F) Threaded Cylinder Bolts. These can be tightened down by hand.







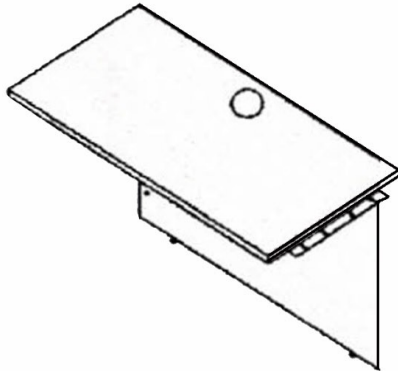



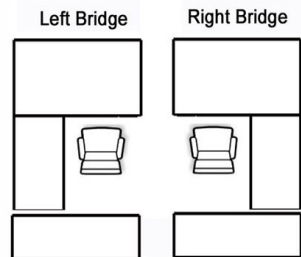



Questions? Please call 1-800-443-5117.
Customer Service available 8:30 - 5:00 Central Time, Monday - Friday

Reversible Desk Bridge BK/FL/MJ/ML/WH2070



ASSEMBLY INSTRUCTIONS



Part	Part	Part
 Wood Dowel	 Shallow Cover	 Worksurface Bracket
 Cam Pin		 Side Panel Brackets (2)
 Cam Lock	 Grommet	 M6 Screw
 Wood Screw	 L-Bracket	 Leveling Glide

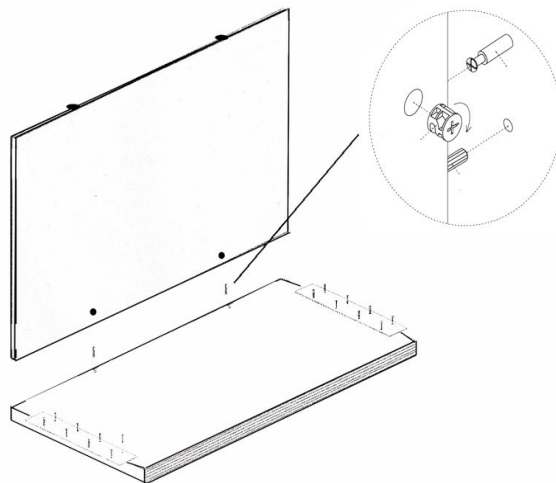

Assemble upside down in carpeted area

- 1.) Assemble with desktop face down on carpet or cardboard for protection during assembly.
- 2.) Attach long, worksurface brackets to underside of bridge. Use round-head screws to attach. Insert all/any hardware on worksurface.
- 3.) Insert any cam locks, cam pins and dowels to the side panel. Connect side panel to top panel using cam locks and pins. Use a Phillips screwdriver to twist the cam locks to secure.
- 4.) Screw in leveling glides on side panel.
- 5.) Carefully turn unit upright. Place in U-desk where you wish to connect. Level the desk if needed. Connect the worksurface brackets on the bridge to the front desk and back desk using same round-head screws.
- 6.) Using pointed wood screws and bent side panel brackets, connect the bridge side panel to the side panels of the front desk and back desk. Center bracket over the seam.
- 7.) Insert the shallow covers over the cam locks. Insert grommet in desktop.

Questions? Please call 1-800-443-5117.
Customer Service available 8:30 - 5:00 Central Time, Monday - Friday

4-Door Hutch Assembly Instructions

MJ2025 - 48"W Hutch and MJ/FL/ML/WH2044 - 71" Hutch

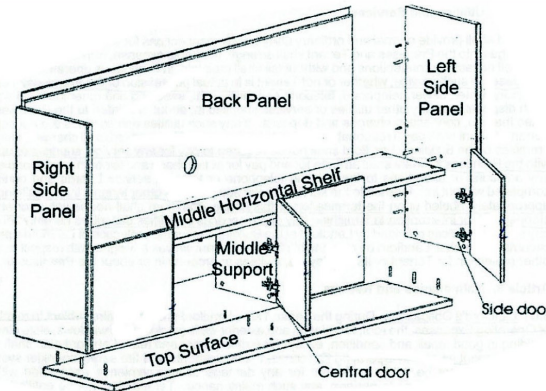

- 1.) Hutch should be assembled upside down until the final step of attaching doors.
- 2.) Insert all cam pins and dowels into hutch top and side panels in preparation of assembly. Identify 8 sets of holes approximately 2" from front edge of panels. Do not insert cam pins in these holes as they will be left open for door hinge brackets. Insert all circular camlocks into camlock holes, with the arrow on face of camlock pointing towards the closest edge of the piece where it will attach to the cam pin.
- 3.) Assemble pieces in following order – do not tighten camlocks until all the pieces are in position. It may be necessary to have a helper hold pieces in place while assembling, or partially tightening some of the connections.
 - A – Attach *Left Side Panel* to *Top Surface*
 - B – Attach *Middle Support* to *Top Surface*
 - C – Attach *Middle Horizontal Shelf* to *Left Side Panel* and *Middle Support*
 - D – Attach *Back Panel* to *Left Side Panel* and *Top Surface*. Make sure all camlocks face the rear of the unit so they are not exposed on front of unit.
 - E – Attach *Right Side Panel* to *Top Surface*, *Horizontal Center Shelf* and *Back Panel*. Do so by making connections to top surface first and then tipping side panel pins/dowels into *Horizontal Center Shelf*.
- 4.) Now tighten all connections until firmly in position.
- 5.) Turn unit over and attach to credenza or desk by peeling two-sided tape from underside and placing firmly in position where it will be used. HINT: It is easier to put the unit in place without the doors because the unit may shift while moving, causing the doors to get out of alignment and have to be readjusted.
- 6.) Attach and only partially tighten the 8 "+" shaped hinge brackets to the interior panels of the hutch with the screws provided. Do not tighten these hinge pieces. Leave them loose so that when the hinges are attached there is some play in them so they can align more easily with the door hinges. This will also allow you to raise and lower the doors so they align evenly with the hutch top panel.

Hinges

7.) Attach hinges to doors. **IMPORTANT:** Set all eight hinges next to each other before attaching. Notice that there are 'short depth' hinges and 'long depth' hinges. Attach the long depth hinges to the outside doors and the short hinges to the two middle doors.

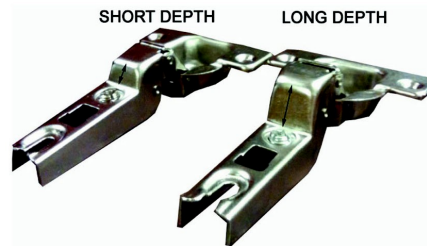

8.) Now tighten interior "+" hinge brackets at desired height so doors are at the same height. Adjust hinge screws to align doors. You will notice that adjusting the fore and aft screws of the hinge adjusts the angle of the doors as needed.

