

Glass Front Reception Desk Assembly Instructions



List of Hardware:

Qty 6 Wood Dowel	1 Sheet Sticker Covers
Qty 24 Cam Pin	Qty 6 Leveling Glide
Qty 30 Cam Lock	Qty 2 Grommet
Qty 4 Mounting Discs/ Dowels for Glass Front Panel	Qty 8 Cam Pins for Glass Counter

Tools Needed:

- Phillips Screwdriver
- A helper!

1.) Assemble on carpet or cardboard to protect parts during assembly. Assembly will require 2 people for safety.

2.) Start by laying down both laminate Front Panels. Insert Cam Pins and Leveling Glides.

3.) Next, locate the Spacers and insert Dowels and Cam Locks. Using a screwdriver, attach the Spacers to the Front Panels by lining up the holes, inserting the Cam Pins into the Cam Locks and twisting the Cam Locks until locked.

4.) Next, with a helper, carefully set the Glass Front Panel, smooth side down, on the Spacers as shown. Line up the holes on both pieces.

5.) Insert the mounting discs through the glass and into the spacers. Twist to screw in and secure. **MAKE SURE YOUR DESK IS LAYING FLAT ON THE GROUND FOR THIS STEP!** Aligning the holes will be much easier.



6.) Locate the Desk Top. Your desk has two height settings for the Desk Top surface: 29"H for seated height and 35"H for standing height. Insert all of the hardware into the holes of the Desk Top and insert the Desktop into the Front Panels and Spaces at your preferred height. **PARTIALLY TIGHTEN ONLY!! DO NOT FULLY TIGHTEN YET!!** Leave yourself wiggle room.

7.) Next, locate both Side Panels. Insert all hardware and attach one side like shown. Then, the other side. **NOW**, you can fully tighten all of the cams on the Desk Top and Side Panels. With a helper, turn the desk upright.

8.) Locate the Glass Counter Next. It will have metal discs already adhered to the glass. Turn the glass disc side up and insert one cam pin per disc. Then, turn the glass disc side down, line up the pins with the holes in the top of the desk and insert. Fully tighten cam locks.

9.) Lastly, insert grommets and place caps over any exposed cam lock holes.



Questions? Please call 1-800-443-5117.

Customer Service available 8:30 - 5:00 Central Time, Monday - Friday

Attaching the File Pedestals to your Standing Height Reception Desk

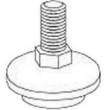

Step 1.) Once your standing height reception desk is assembled and upright, it will need to be anchored down with the pedestal to prevent tipping. Unpack your drawer pedestal(s) and insert four leveling glides to the bottom of the file. Then, attach the drawer pulls using the screws provided.

Part	Part
 4 Large Bolts	 3 Drawer Pulls with screws
 1 set of keys	 4 Leveling Glides

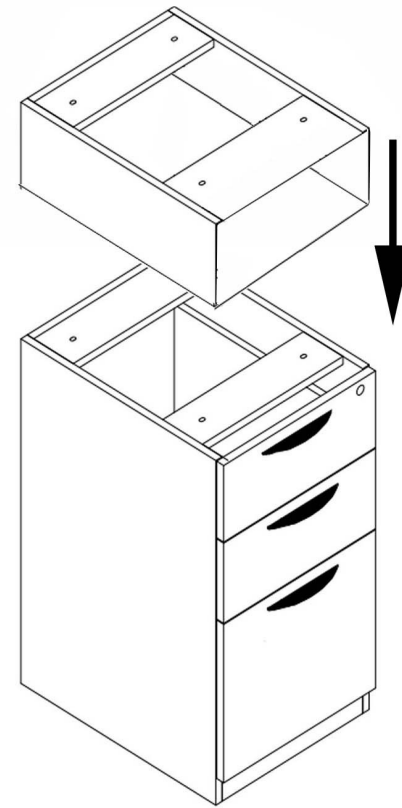

Step 2.) Unpack your Open Storage Cubby from its box. This unit attaches to the top of file pedestal using 4 bolts.

Step 3.) Once the Open Storage Cubby is attached, you will need to slide the unit underneath the desktop of the standing height reception desk, either on the left or right. Use the four additional bolts to attach to the underside of the desk. There are inserts installed on the underside of the desktop for the bolts for file, on the left and right side.

Questions? Please call 1-800-443-5117.

Customer Service available 8:30 - 5:00 Central Time, Monday - Friday