

# Instruction

## Adjustable Dumbbell

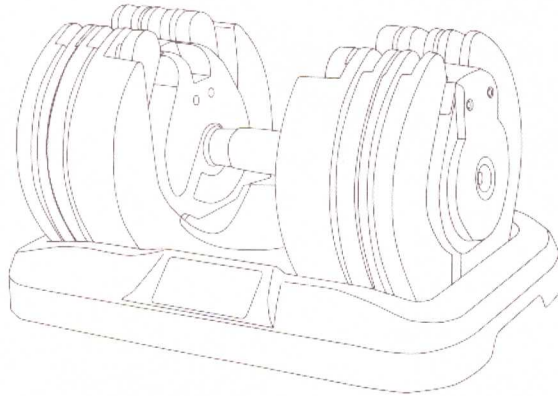

First step: Select weights

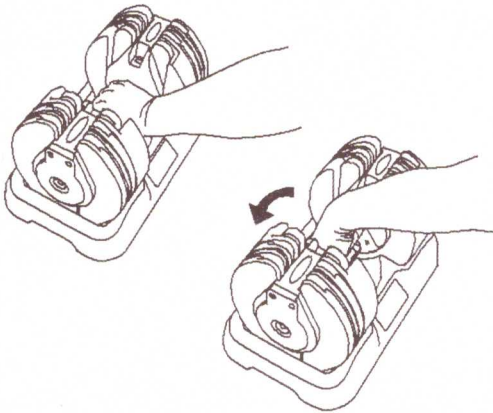

Second step: Choose Kg and LB

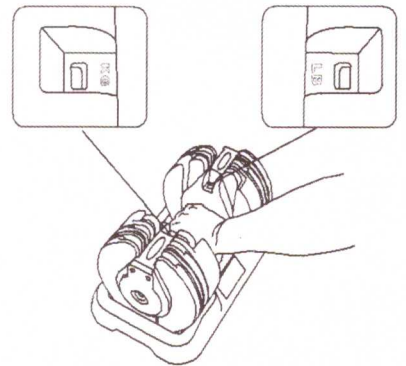

Third step: Lift up the dumbbell plate

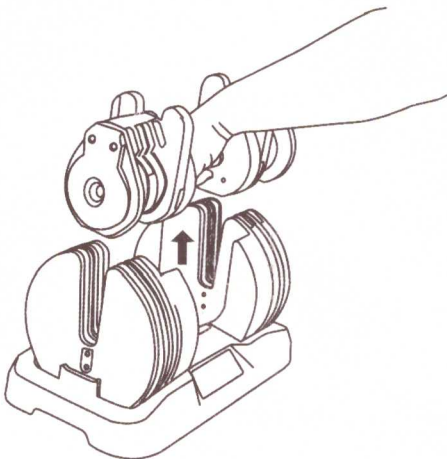

Fourth step: After using, put back the handle

