



Since 1978

www.modernofficefurniture.com

For customer service call

1-800-443-5117

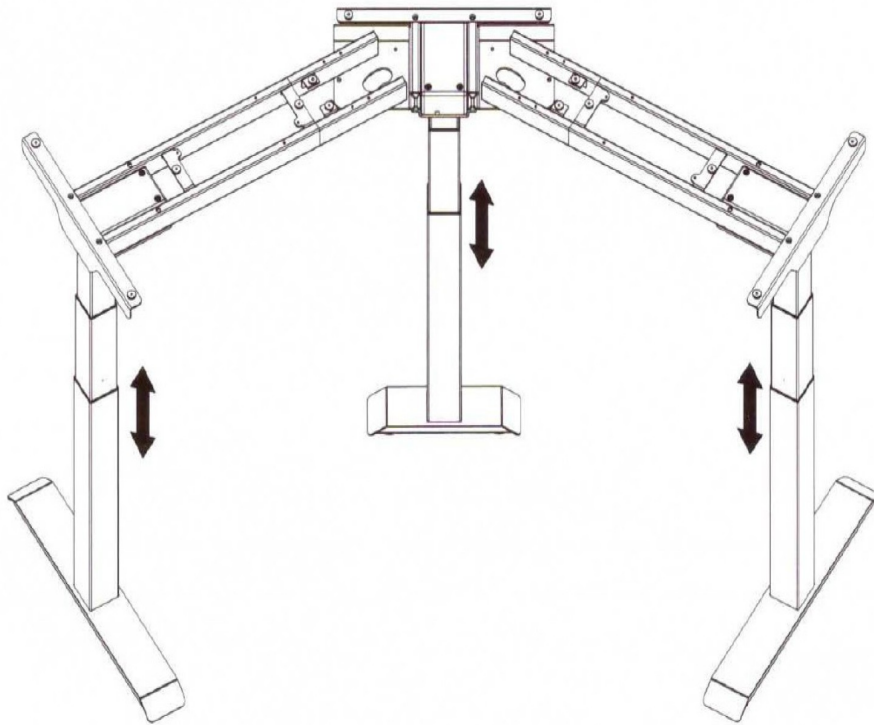







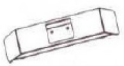

Technical data

Column qty	3
Max Loading capacity	150KG
Height range	580-1230mm

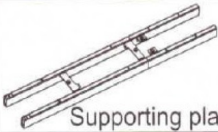
Accessory list

No.	Image	Spec	Qty	
A		M6	6	
B		M6	8	
C		M6	16	
D		M6	12	
E		M8	4	
F		St4.2	24	
G		St4.2	6	
H		Wiring fixing seat	6	
I		Wrench 4x4mm	Wrench (with cross) 5x5mm	1

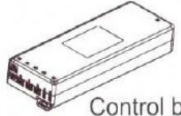
Component list

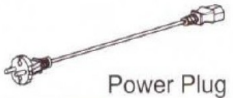
No.	Part	Qty	No.	Part	Qty
①	 Long foot	2	②	 Short foot	1
No.	Part	Qty	No.	Part	Qty
③	 Lifting column	3	④	 Supporting beam	3
No.	Part	Qty	No.	Part	Qty
⑤	 Supporting plate	2	⑥	 Left connecting plate	1
No.	Part	Qty	No.	Part	Qty
⑦	 Right connecting plate	1	⑧	 Hand Switch	1
No.	Part	Qty	No.	Part	Qty
⑨	 Control box	1	⑩	 Cable	1
No.	Part	Qty			
⑪	 Power Plug	1			

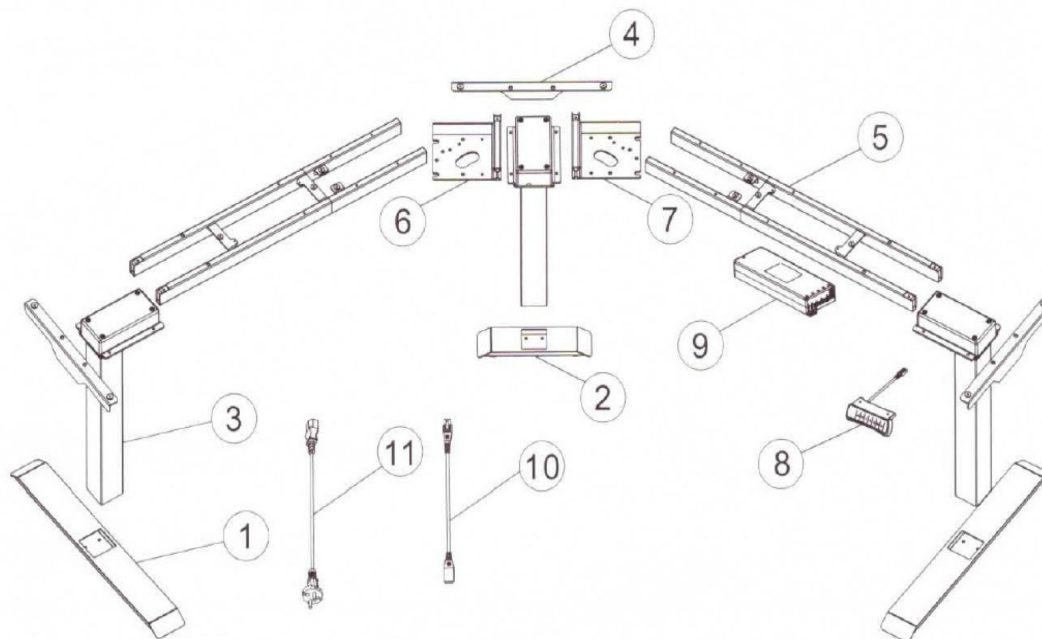

Note: This standing desk has three angle installation methods, 90°, 120° and 180°

STEP 1

Install left and right connecting plates

90° Installation

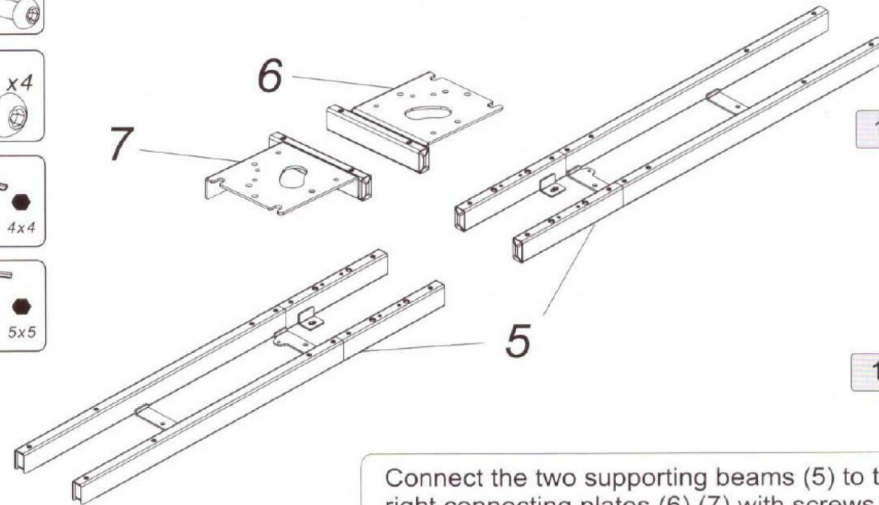
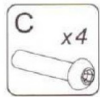

Connect the two supporting beams (5) to the left and right connecting plates (6) (7) with screws (C) and (E) respectively. There are three angles to choose at will, and finally tighten them with a wrench (I)

120° Installation

180° Installation

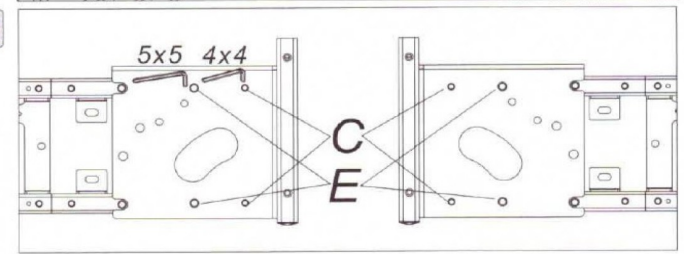
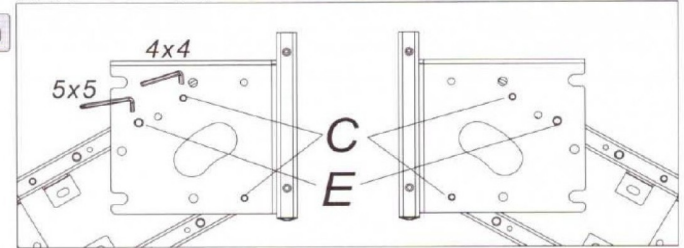
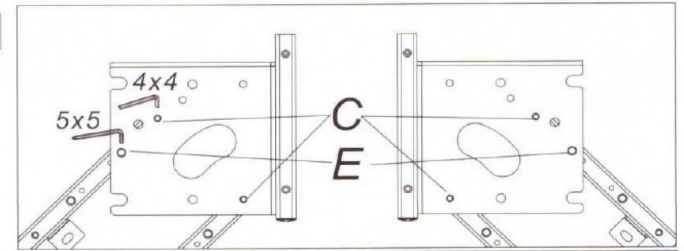

STEP 2

Install lifting columns

120° Installation

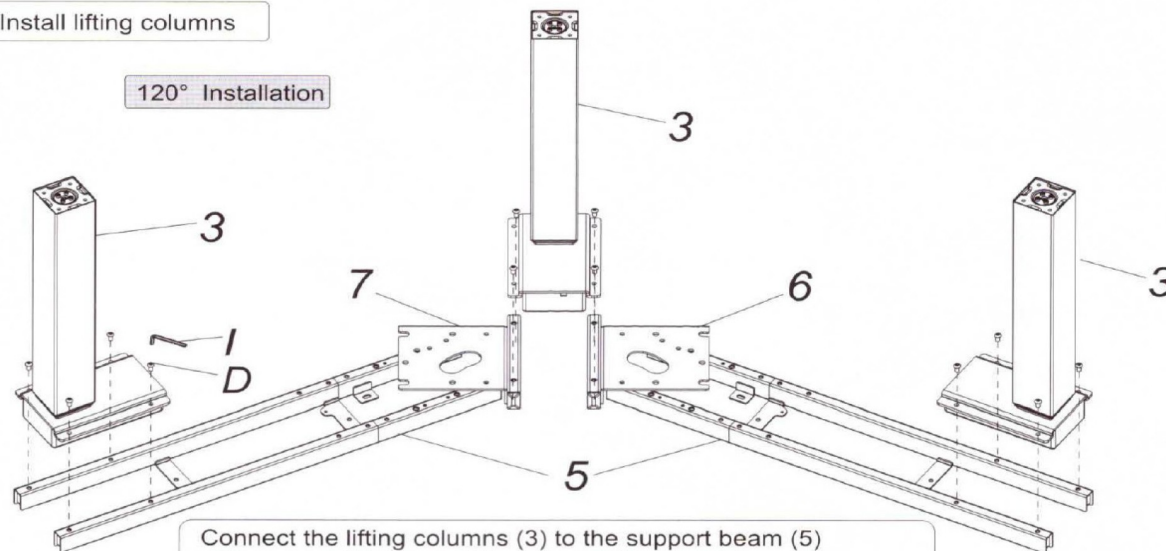

Connect the lifting columns (3) to the support beam (5) with screws (D), the middle column (3) to the left and right connecting plates (6) (7), and the wrench (I) to tighten the screws; 90° and 180° are installed in the same way as 120°.

STEP 3-1

Install the Feet



90° and 120° installation

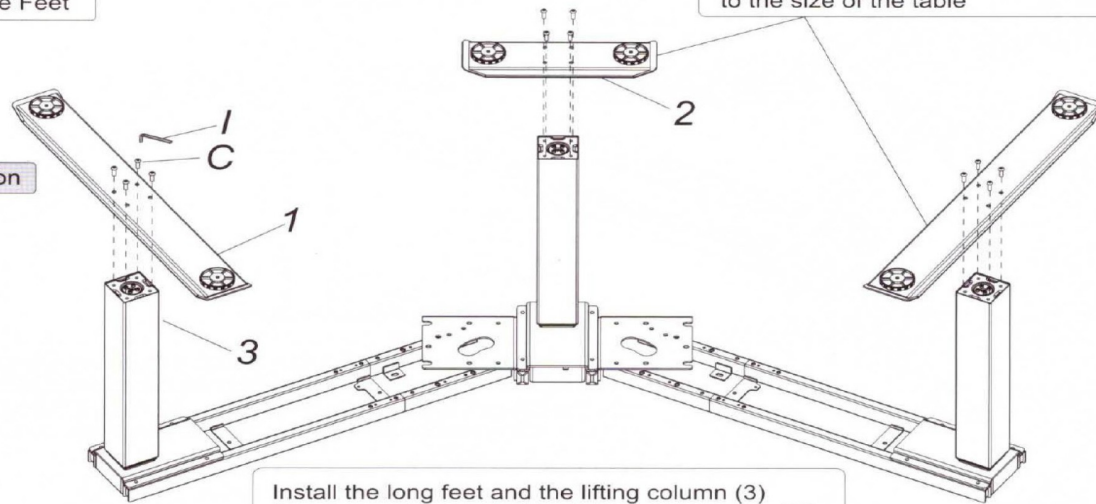

Install the long feet and the lifting column (3) together, use wrench (I) to tighten the screws (C).

STEP 3-2

180° Installation

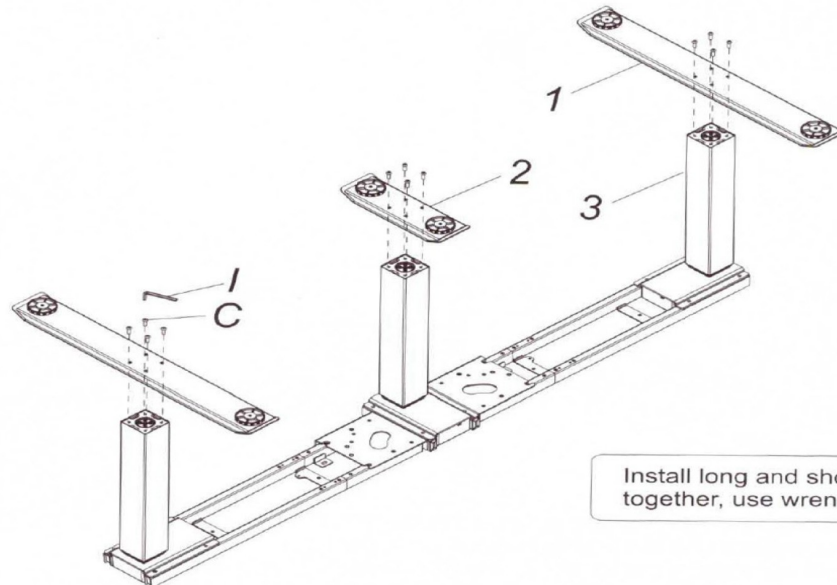

Install long and short the feet(1)(2) and the lifting column (3) together, use wrench (I) to tighten the screws (C).

STEP 4

Install the supporting plate

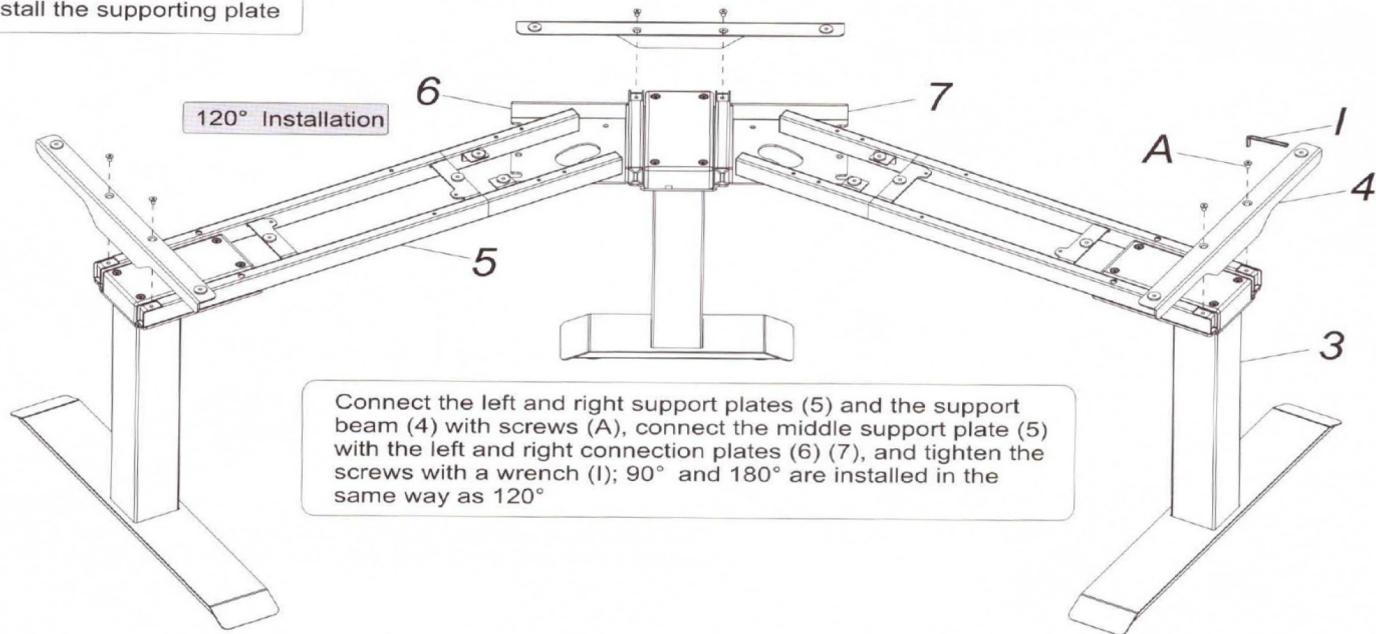

Connect the left and right support plates (5) and the support beam (4) with screws (A), connect the middle support plate (5) with the left and right connection plates (6) (7), and tighten the screws with a wrench (I); 90° and 180° are installed in the same way as 120°

STEP 5

Connect All the Cables onto the Control Box

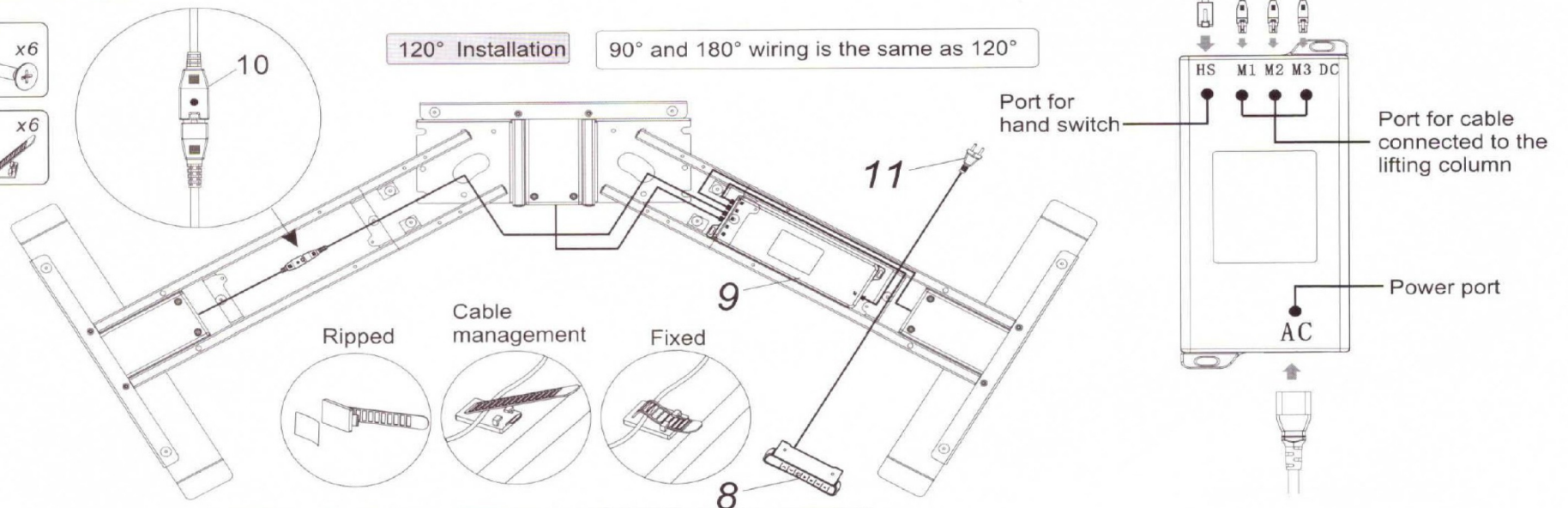

The wiring fixing seat (H) can be glued to the desk board, and can also be screwed to the desk board with screws (G)

STEP 6-1

Install the Tabletop and Hand Switch

90° Installation

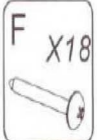

Use (F) wood screws to attach desktop(s). Wood screws are self-drilling so you can position top(s) how you like and drill your own holes accordingly. Use power screwdriver to install.

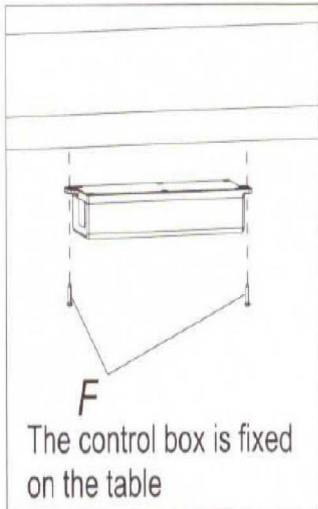
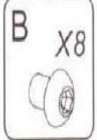

Add two flat brackets x2 under surfaces at seam prior to attaching frame

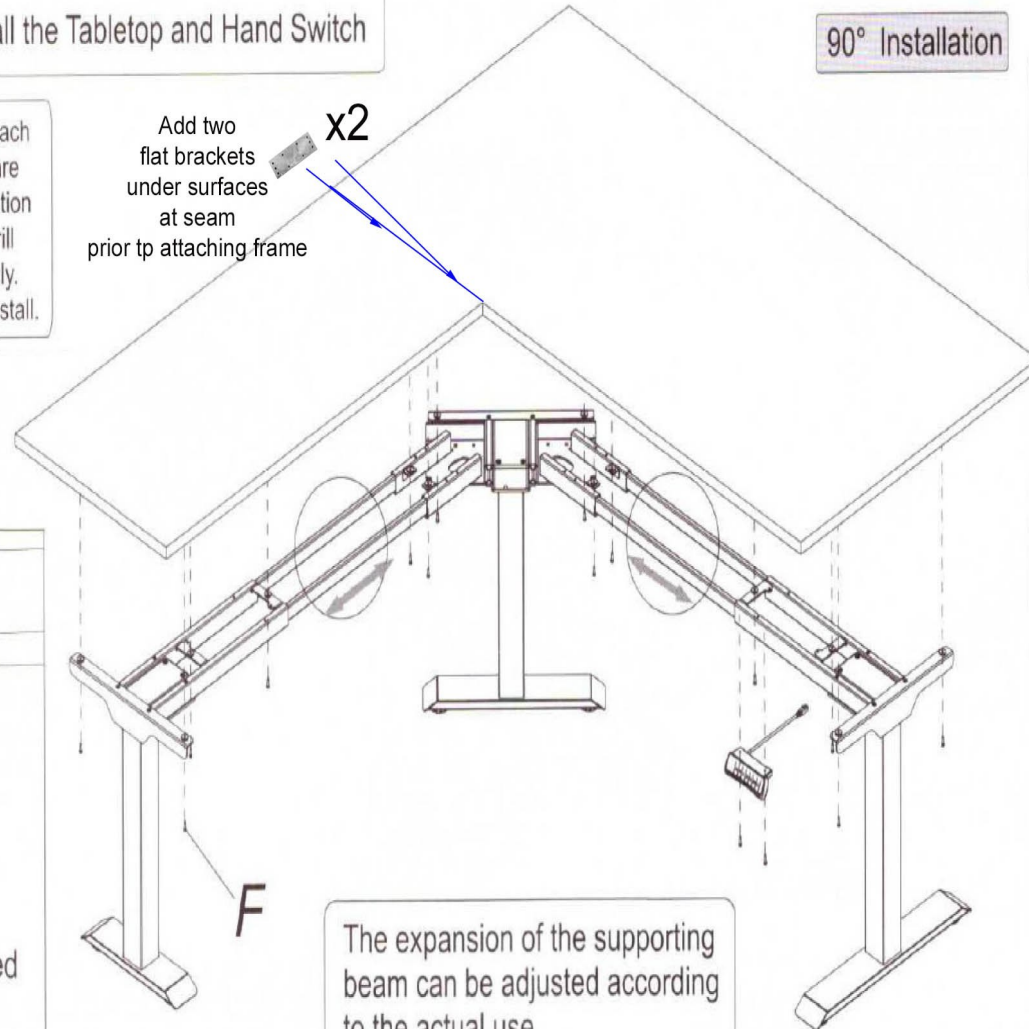

The expansion of the supporting beam can be adjusted according to the actual use.

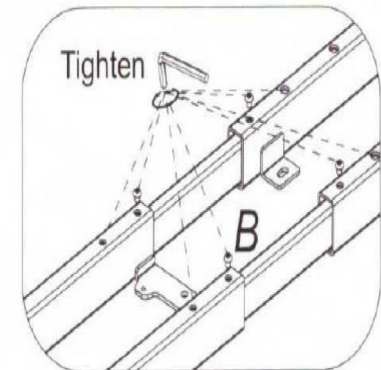
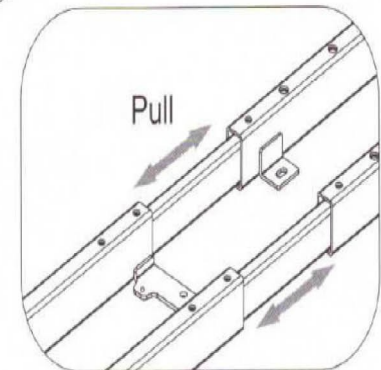
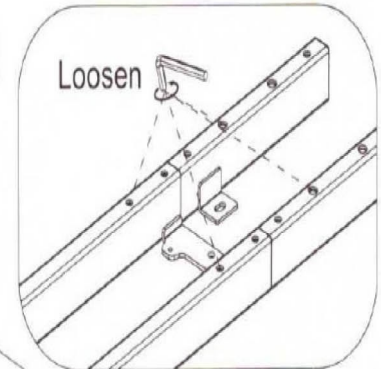

Desk/Credenza Shell Assembly Instructions

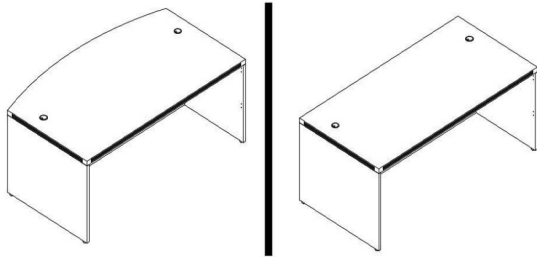

Applies to:

(BK/CH/MJ/ML/MWAL/WH) 2001/2002/2043/2089/3624/7124

List of Hardware:

Part	Part
 Wood Dowel	 Cap
 Cam Pin	 Leveling Glide
 Cam Lock	 Grommet

Tools Needed:

- Phillips Screwdriver
- A helper!

1.) Assemble on carpet or cardboard to protect parts during assembly. Assembly will require 2 people for safety.

2.) Locate left & right side panels. Screw in the leveling glides by hand. Then, insert wood dowels & cam pins. The wood dowels fit into the slightly larger holes, compared to the cam pin holes

3.) Locate front panel and insert all cam locks on the left & right sides. Then, align one of the side panels and connect the panel by inserting the cam pins into the cam locks and the dowels into the corresponding holes. (see diagram on next page). Twist the cam locks with a Phillips Screwdriver to secure.

Special Note:

Location & number of cam pin, cam lock and dowel holes may vary.

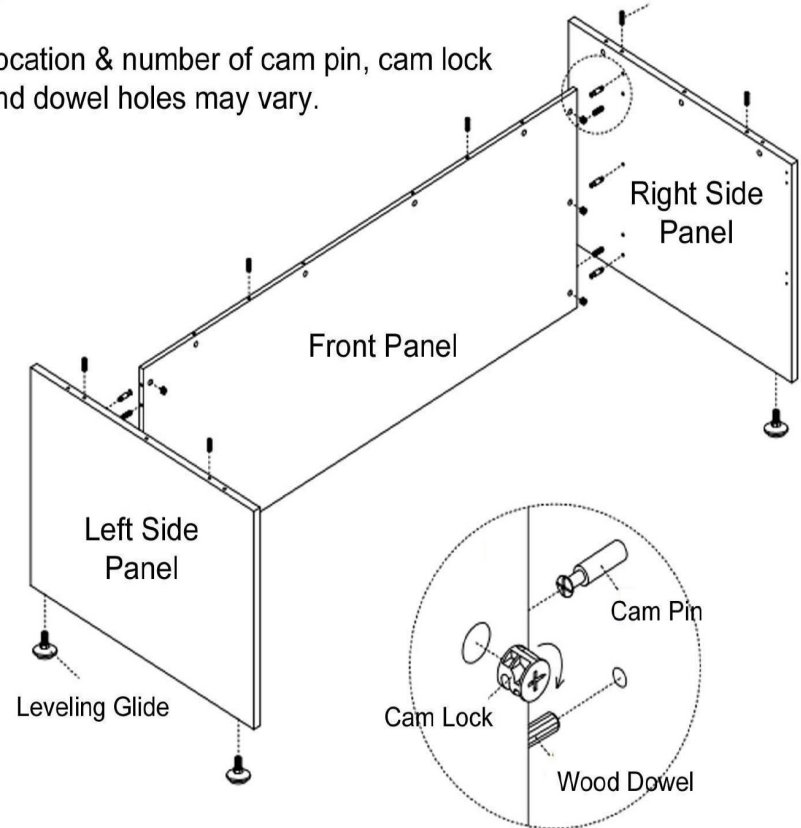

4.) Next, insert all cam pins, dowels and cam locks on the top edges of the side panels and front panels. Locate the desktop and with a helper, carefully set the desktop on top of the assembly shown above. Twist cam locks to secure the connection.

5.) Your last step is to insert the grommet(s) provided into the desktop. Cover the cam locks with the caps provided.

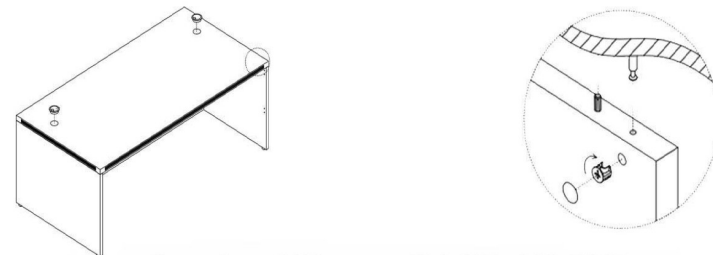

Questions? Please call 1-800-443-5117.

Customer Service available 8:30 - 5:00 Central Time, Monday - Friday



Box/Box/File Desk Pedestal Assembly Instructions

Applies towards:

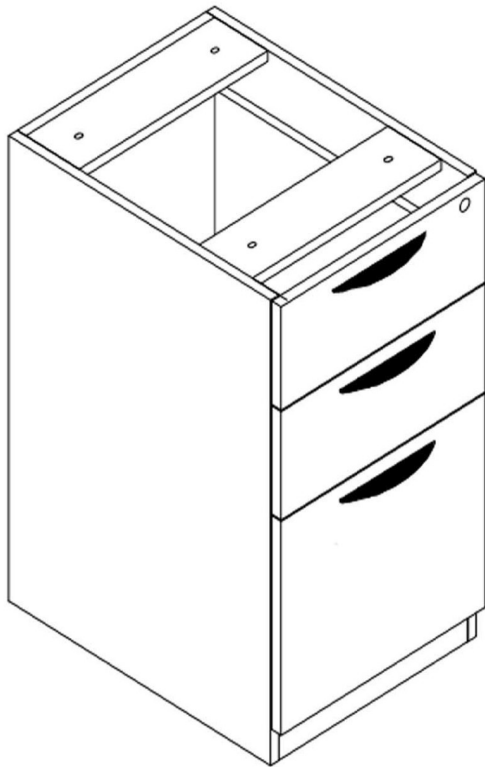
BK/CH/FL/MJ/ML/WH2066

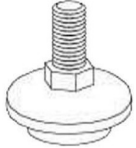

List of Hardware:

Part	Part
 4 Large Bolts	 3 Drawer Pulls with screws
 1 set of keys	 4 Leveling Glides

1.) Install 4 leveling glides.

2.) Use the screws to attach drawer pulls.

3.) To install under desk, remove the top box drawer (or top two box drawers) by locating the black tabs inside of the left & right drawer slides. Push down on one and push up on the other. This will release the drawer from the slides. Use 4 large bolts to connect to threaded holes on underside of desk. Once done, simply insert drawers back into the slides. They will snap in place.

Questions? Please call 1-800-443-5117.

Customer Service available 8:30 - 5:00 Central Time, Monday - Friday

4-Door Hutch Assembly Instructions

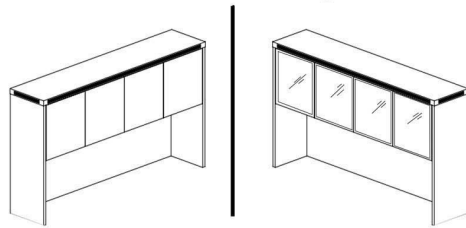



Applies to:
BK/CH/FL/MJ/ML/WH2044
MJ2025-CHL

Questions? Please call 1-800-443-5117.

Customer Service available 8:30 - 5:00 Central Time, Monday - Friday

List of Hardware:

Part	Part	Part
		Qty 4 
		Qty 4 
		Qty 8 

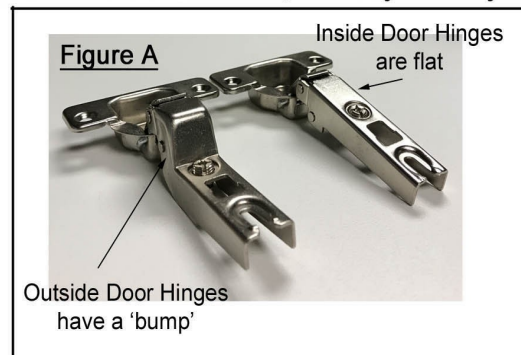

1.) Locate the Back Panel, Left & Right Side Panels and Center Shelf. Insert all wooden dowels, cam pins and cam locks. Connect Back Panel to the Center Shelf. Then connect the Left Side Panel, then Right Side Panel. Once all panels are connected, use your screwdriver to twist the cam locks to secure the connections.

2.) Connect the Middle Support Panel in same method.

3.) Attach Top Surface in same method.

4.) Attach all 8 Hinge Plates to the inside walls of the hutch. Use two per door. The holes are piloted. **DO NOT TIGHTEN DOWN THE SCREWS ALL OF THE WAY. LEAVE WIGGLE ROOM!**

Tools Needed:

- Phillips Screwdriver
- A Helper

Special Note:

Location & number of cam pin, cam lock and dowel holes may vary.

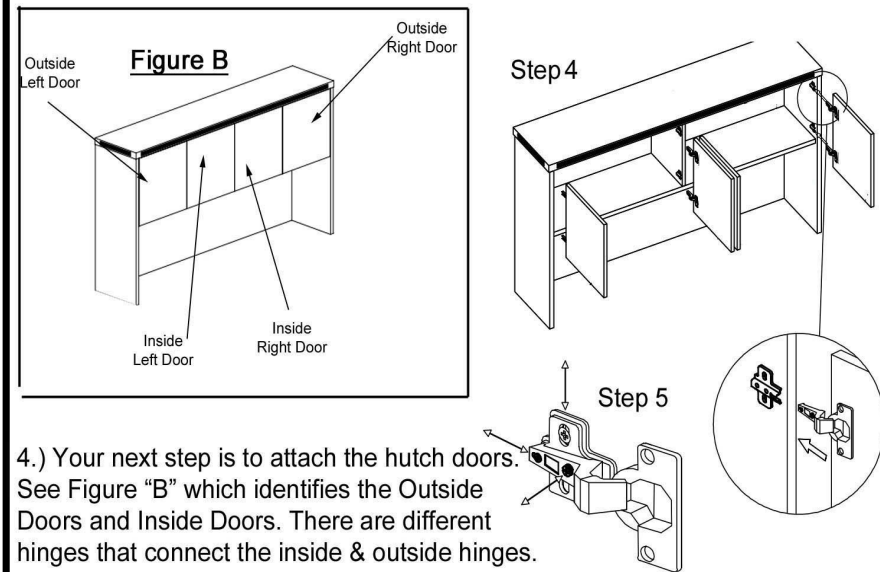
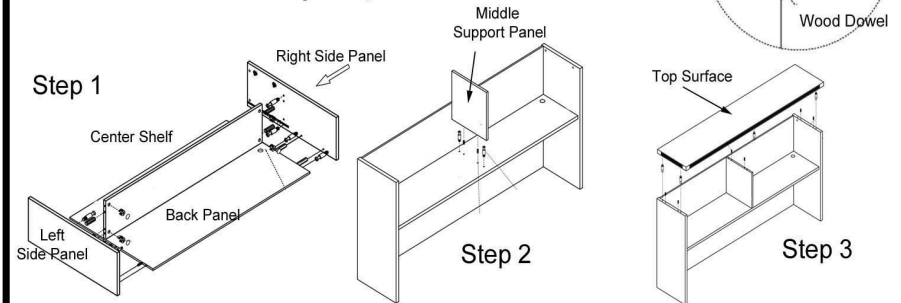

4.) Your next step is to attach the hutch doors.

See Figure "B" which identifies the Outside Doors and Inside Doors. There are different hinges that connect the inside & outside hinges.

See Figure "A" to help identify. Attach two hinges per door. Use the hinges with the 'bump' on the Outside Left & Right Doors and the flat hinges on the Inside Left & Right Doors. The holes are piloted. Use the screws provided. Once the hinges are attached, slide the hinges over the Hinge Brackets, fitting the screw head of the Hinge Bracket in the slot of the Hinge. Once fitted, slightly tighten the set screw. Now, set your hutch on your desk. Use the double-sided tape to securely adhere to desktop.

5.) Next, it is time to adjust the doors so that they properly align. Using your screwdriver, turn the Set Screw on the hinge to adjust the depth and the screws on the hinge plate to move the door up/down.

6.) Last step is to install Cam Lock Caps and Grommet cover.

Video on Hinge Door Adjustment available at link:

<http://www.modernofficefurniture.com/office-furniture-assembly-instructions.html>

"How to Adjust Hinges on 4-Door Hutch"