

Cherry Laminate Reception Desk Assembly Instructions

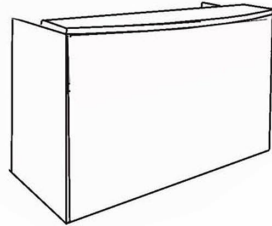

MJ2069-CHL

List of Hardware:

Part	Part
 Wood Dowel	 Cap
 Cam Pin	 Leveling Glide
 Cam Lock	 Grommet

Tools Needed:

- Phillips Screwdriver
- A helper!

- 1.) Assemble on carpet or cardboard to protect parts during assembly. Assembly will require 2 people for safety.
- 2.) First, screw in all leveling glides and insert all wooden dowels, cam locks and cam pins into the panels
- 3.) Lay the front panel on the ground and connect one of the Side Panels. Use a Phillips Screwdriver to twist each cam lock to secure each cam pin.
- 4.) Next, attach the desktop to the Side Panel and Front Panel.
- 5.) Attach the other Side Panel.
- 6.) Attach the Counter Top using same hardware method.
- 7.) Your last step is to insert the grommets into the desktop and caps over the cam locks.

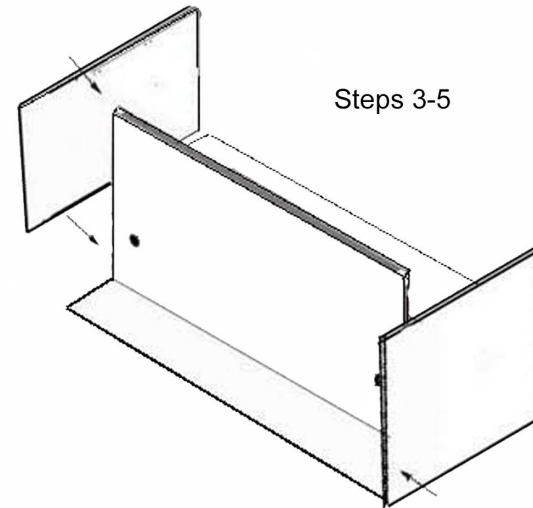

Steps 3-5

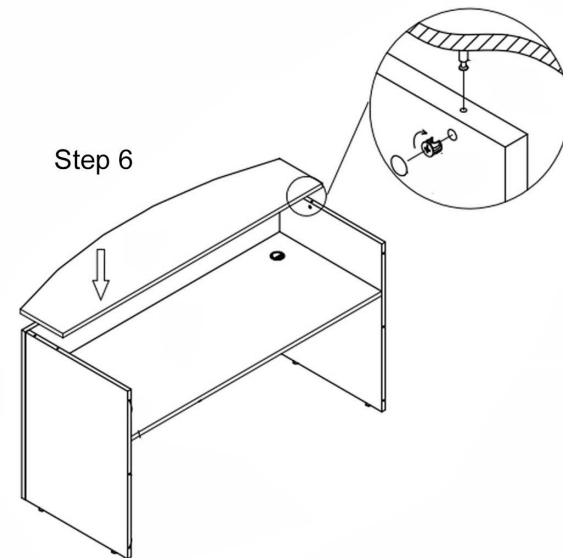

Step 6





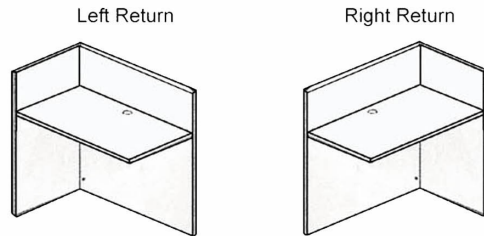





Questions? Please call 1-800-443-5117.
Customer Service available 8:30 - 5:00 Central Time, Monday - Friday

Reception Return Desk Assembly Instructions

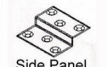

Applies to:
BK/CH/FL/MJ/ML/WH2080

List of Hardware:

Part	Part	Part
 Wood Dowel	 Shallow Cover	 Worksurface Bracket
 Cam Pin	 Deep Cover	 Side Panel Brackets (2)
 Cam Lock	 Grommet	 M6 Screw
 Wood Screw		 Leveling Glide

Tools Needed:

- Phillips Screwdriver
- Power Screwdriver
- A Helper

- 1.) Assemble on carpet or cardboard to protect parts during assembly. Assembly will require 2 people for safety.
- 2.) Determine if the return will be left or right handed (see diagram next page). Locate Side Panel & End Panel and arrange like shown in drawing. Insert leveling glides, then insert all cam pins, cam locks and wood dowels. Then connect the panels by inserting the dowels into the holes on opposite panel and inserting cam pins into cam locks (see diagram). Then, twist the cam locks with a Phillips Screwdriver to secure connection.
- 3.) Next, locate the Desktop and insert hardware. Then, set the desktop on the lower assembly and twist cams to securely connect.

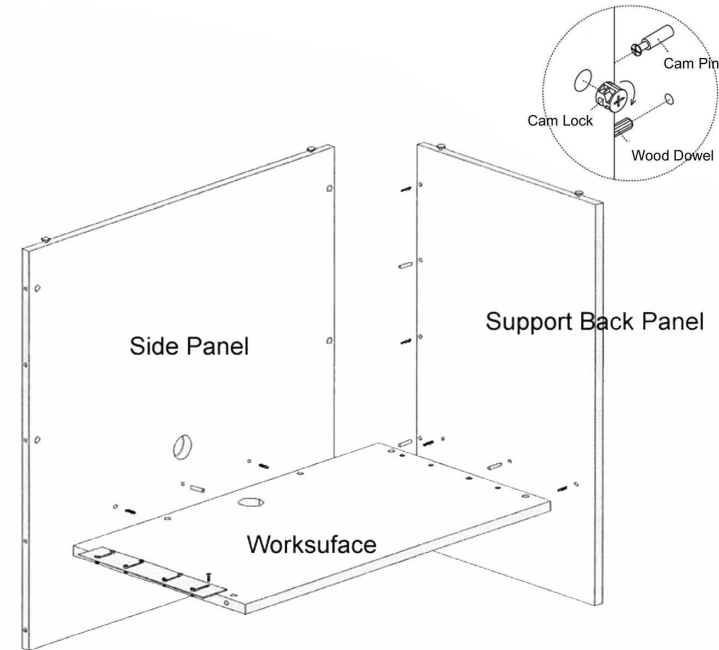

Picture shows a left return being assembled, upside down.

- 4.) Now it's time to attach the return to your desk. Locate the large flat bracket and M6 machine screws (it may be attached to the desktop already. If not, center the bracket over the edge and install 4 of the screws). With a helper, have one person hold the return desk stable while the other screws the machine screws into the desk.
- 5.) Once installed & leveled, use the wood screws to install the offset side panel brackets. This will further secure the side panel, but is an optional step. A power screwdriver is helpful.
- 6.) Lastly, insert the grommet into the desktop and use the caps provided to cover the cam locks.

Questions? Please call 1-800-443-5117.



Customer Service available 8:30 - 5:00 Central Time, Monday - Friday

Box/Box/File Desk Pedestal Assembly Instructions

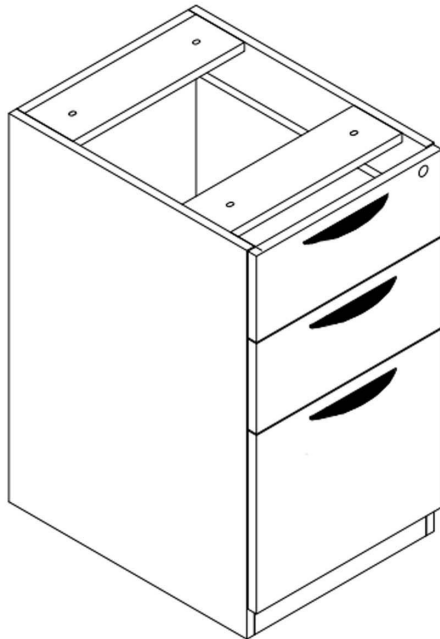
Applies towards:
 BK/CH/FL/MJ/ML/WH2066

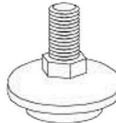

List of Hardware:

Part	Part
 4 Large Bolts	 3 Drawer Pulls with screws
 1 set of keys	 4 Leveling Glides

- 1.) Install 4 leveling glides.
- 2.) Use the screws to attach drawer pulls.
- 3.) To install under desk, remove the top box drawer (or top two box drawers) by locating the black tabs inside of the left & right drawer slides. Push down on one and push up on the other. This will release the drawer from the slides. Use 4 large bolts to connect to threaded holes on underside of desk. Once done, simply insert drawers back into the slides. They will snap in place.

Questions? Please call 1-800-443-5117.
 Customer Service available 8:30 - 5:00 Central Time, Monday - Friday