



A-Frame Desk Series Assembly Guide - Frame Only

Questions: Call 1-800-443-5117, 8:30-5, Central Time, Mon-Fri

<p>Leg</p> <p>Qty 2</p>	<p>Cross Bar</p> <p>Qty 1</p>	<p>Cross Beam Bolts</p> <p>Qty 16</p>	<p>Knob / Spacer Set</p> <p>Qty 2 Sets</p>
<p>Steps 1 - 2</p>			<p>Step 1) Attach Cross Beam to Legs using 16 C Screws, 4 in each corner.</p> <p>Step 2)- Desk frame is width adjustable. Space out your frame to your desired width (66"W or 71"W) and add the D - Knobs & Spacers to tighten in place. (See Picture Left)</p>

Attaching Solid Wood Top - AFR-WOODSCREWS INSTRUCTIONS

Hardware Included	Rectangular Desks Need:	L-Desks Need:
Qty 18 - 1" Self Threading Wood Screws	8	18
Qty 18 - Washers	8	18

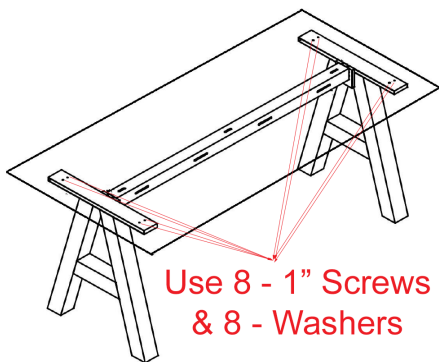

Tools You Will Need: Power Drill/Screwdriver - Assemble on carpet or blanketed floor for protection!

Attaching Top to Main Desk Frame: Position assembled steel base on underside of wood top. Use a power drill/screwdriver to screw the 1" Self-Threading Wood Screws with Washers through the holes of the legs. You are making your own holes. Screws drill into the solid wood top for a strong and durable connection.

Assembling Return for L desk - Determine if you want a Left or Right Return. Then, use four 1" Self-Threading Wood Screws and four Washers to attach the 24" leg onto the Return Desk Top. Finally, using an six additional 1" Self-Threading Wood Screws and Washers, attach the Connecting Plate over the seam of the main desk and return desk on your preferred side.

Left Hand Return

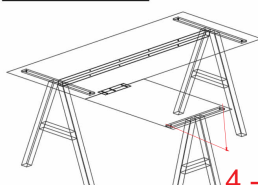

**4 - 1" Screws
4 - Washers**

Right Hand Return

