



**Weight capacity: 300LBS**

## **ASSEMBLY INSTRUCTION ——— Y14249 CHAIR**

### **Before You Begin**

Please identify all component parts and hardware pieces required before you begin. Carefully remove all of the components from the packing and set aside for assembly. Assemble on a soft surface to prevent scratching during assembly.

### **Caution:**

Tighten all components securely before use. Failure to do so may result in personal injury.  
DO NOT use any sharp objects to open plastic wrapped components as damage to product or components may result.

### **Warning:**

CHOKING HAZARD - Small Parts. Adult Assembly Required.  
DO NOT ALLOW CHILDREN TO CLIMB ON FURNITURE.



## COMPONENT LIST

**Part 1** Back Frame x 1

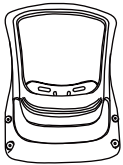

**Part 2** Seat x 1



**Part 3** Right Arm x 1



**Part 4** Left Arm x 1

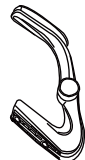

**Part 5** Mechanism x 1

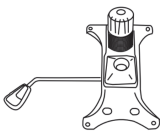

**Part 6** Gas Lift x 1



**Part 7** Gas Lift Cover x 1



**Part 8** Base x 1

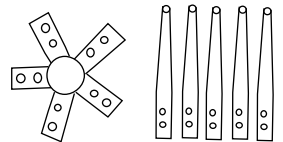

**Part 9** Castor x 1



## HARDWARE LIST

**Part A**  Bolt M6 x12 mm QTY 10

**Part E**  M6 Flat Washer#14 QTY 4

**Part B**  Bolt M6 x25 mm QTY 4

**Part F**  Plastic Cover QTY 4

**Part C**  Bolt M6 x 30 mm QTY 4

**Part G**  Allen Wrench QTY 1

**Part D**  Bolt M6 x25 mm QTY 4

**STEP 1 :**

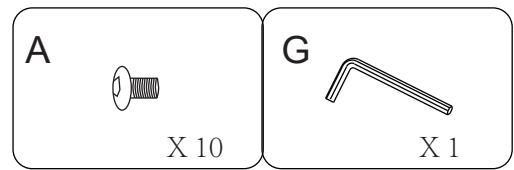
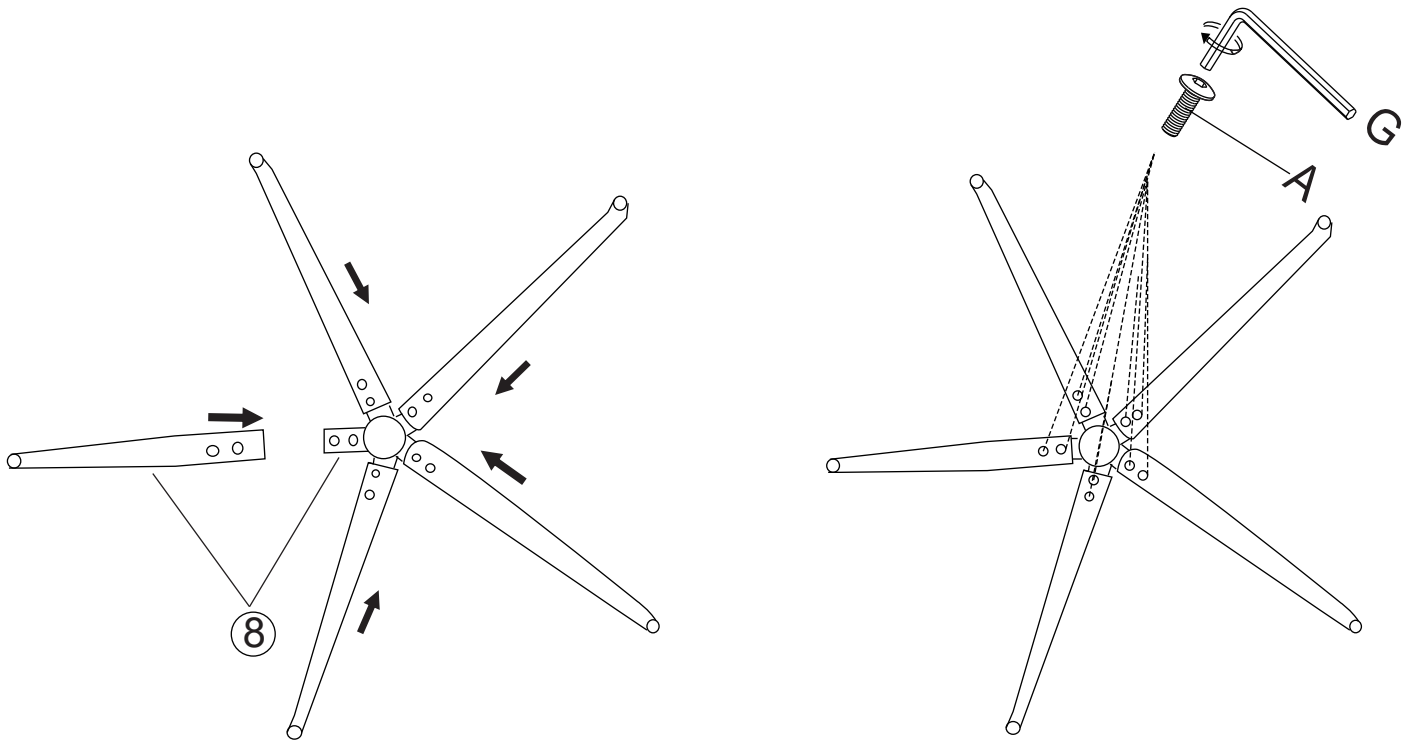

Hardware & Tools required

**STEP 2 :**

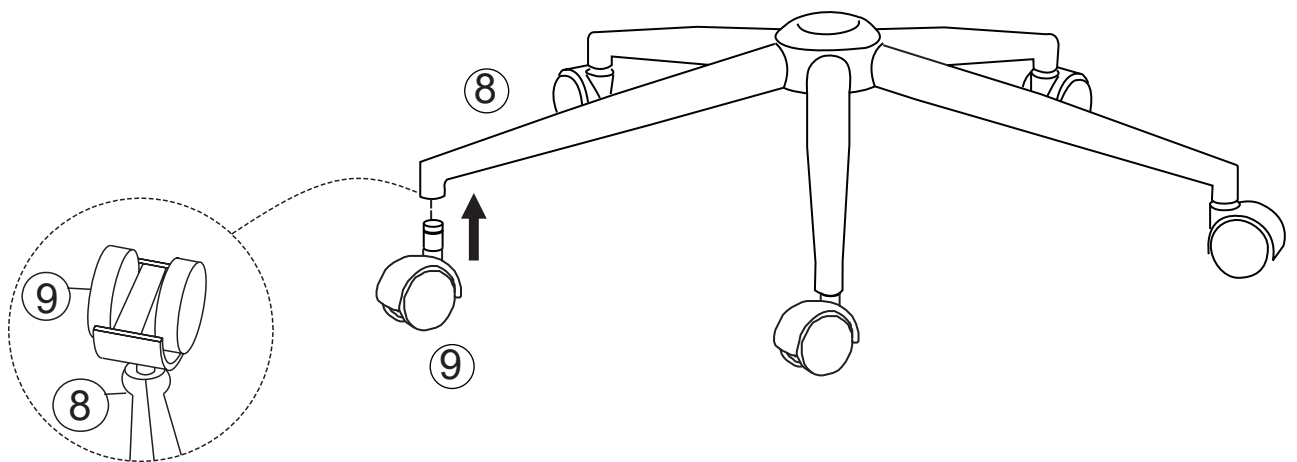

**STEP 3 :**

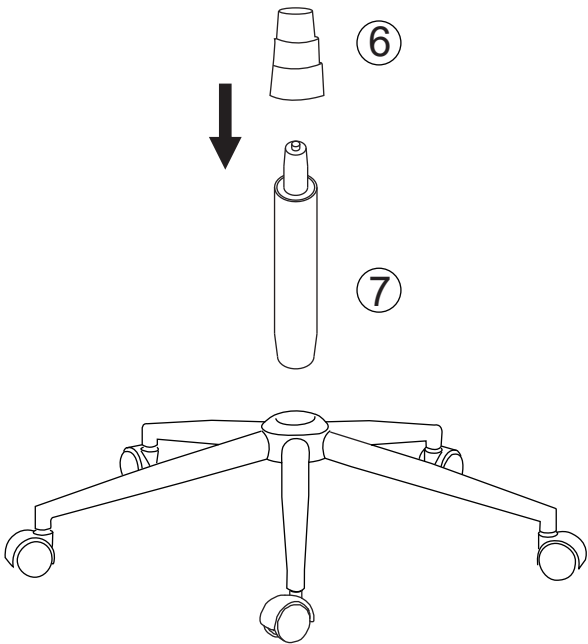

**STEP 4 :**

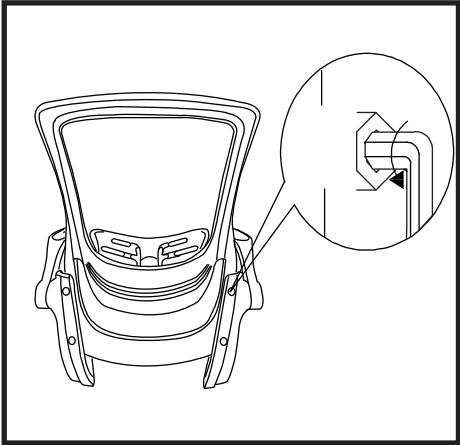
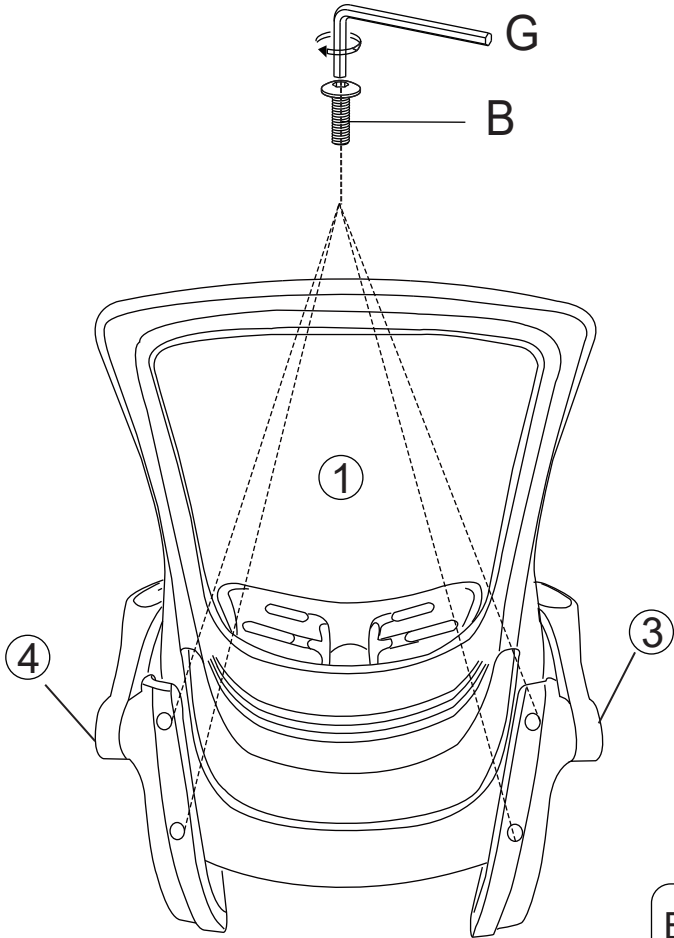

**Do not tighten Screws fully until you have completed assembly.**

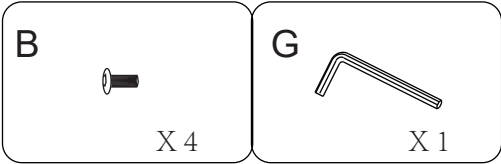

**Hardware & Tools required**

**STEP 5 :**

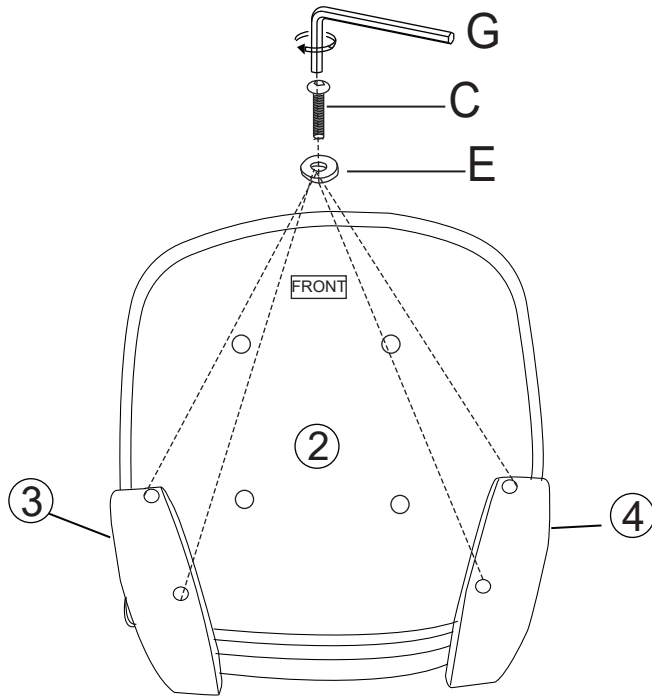

**Fully tighten the screws with Allen Key (G).**

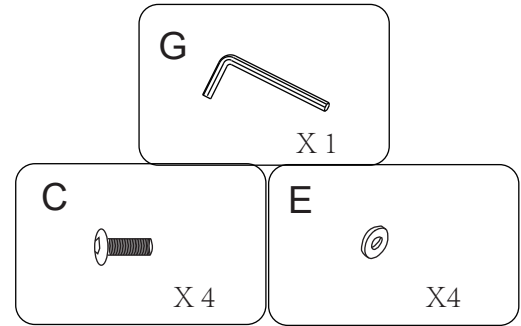

**Hardware & Tools required**

**STEP 6 :**

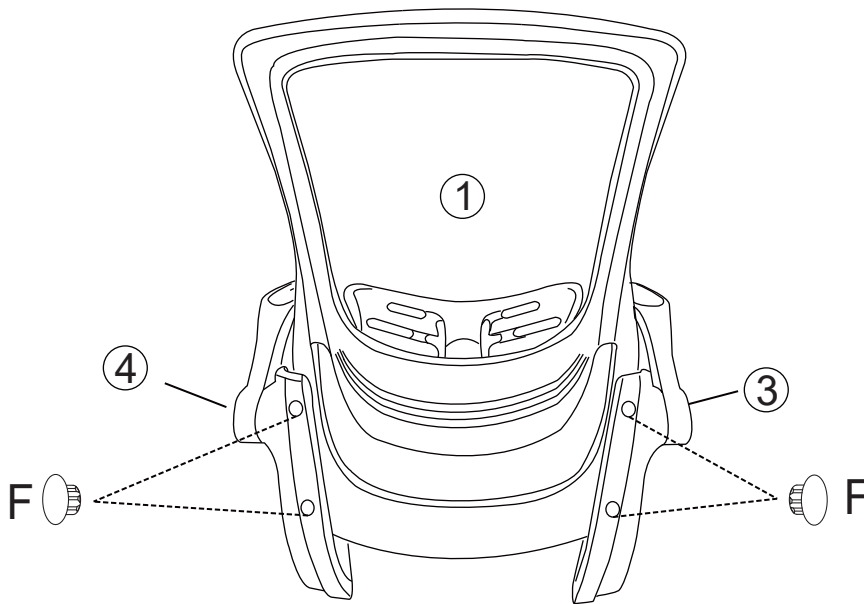

## STEP 7 :

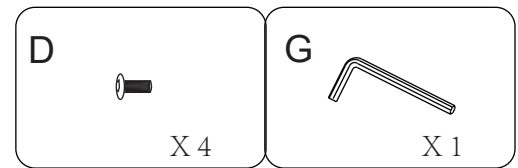
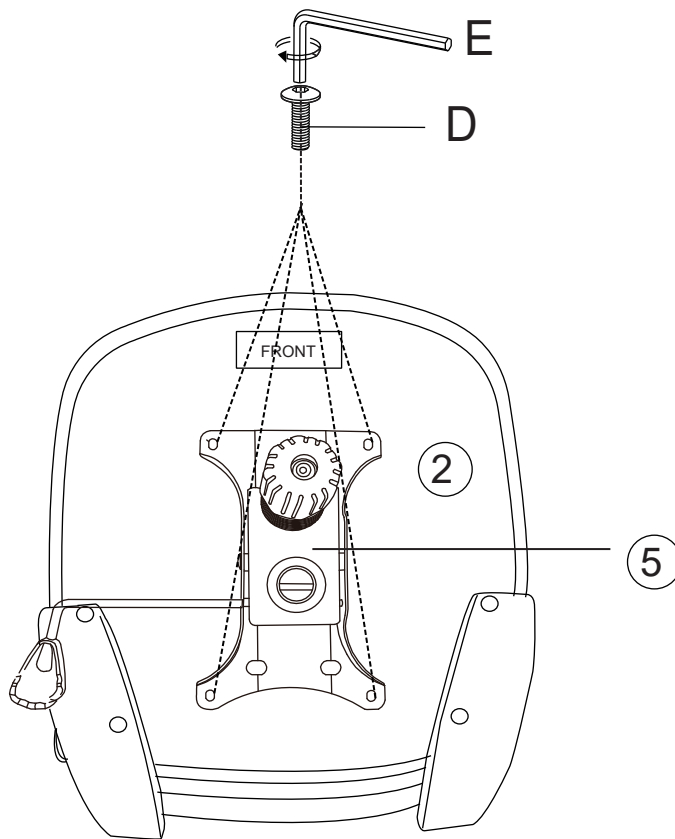

Hardware & Tools required

## STEP 8:

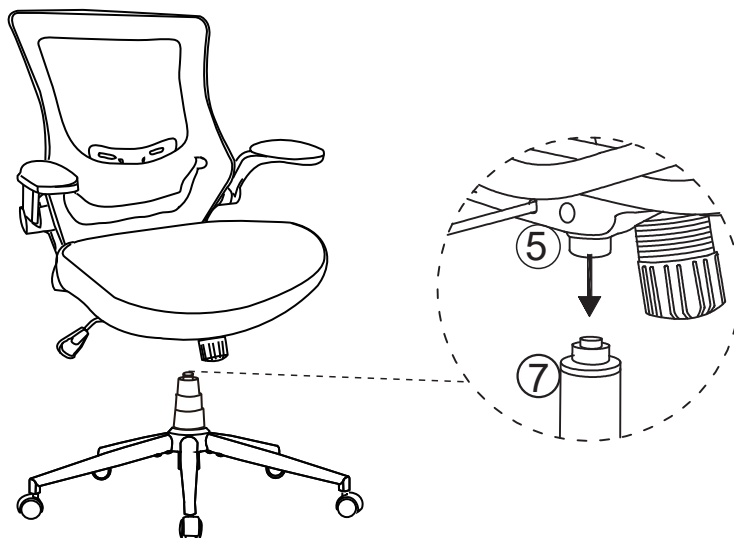



**Your Chair is now complete and ready for use.**

**IMPORTANT NOTE: Periodically check and re-tighten screws.**

### **Care Instructions**

- Vacuum regularly
- Wipe PU upholstery and non-upholstered parts with a clean damp cloth and mild soap. Wipe PU upholstery dry immediately with an absorbent dry cloth.
- Spot clean mesh with upholstery shampoo or dry powdered cleaner only. Test on a concealed area before proceeding. Apply proprietary cleaning products strictly according to instructions.
- Do not saturate upholstery with water or other cleaning products.
- Treat spills immediately with an absorbent cloth by blotting the spill.
- Do not use detergents, solvents or abrasive cleaners.
- Keep away and protect from direct sunlight and heat.
- Avoid contact with skin, in particular during high temperatures and humidity.
- Clean, check and tighten parts regularly.

# Y14249 CHAIR

## Functionity



### \* Flip Back Armrest



### \* Chair Height Adjustment

- To increase chair height pull lever upward while lifting body weight slightly off the seat.
- Release lever at desired height.
  
- To lower chair height sit fully into the chair and pull lever upward.
- Release lever at desired height.



### \* Chair tension function

- Pull lever out to unlock & allow chair to tilt back & forth

### \* Adjustable Chair Tension Speed

- Turn continuously to adjust how quickly chair tilts back & forth.

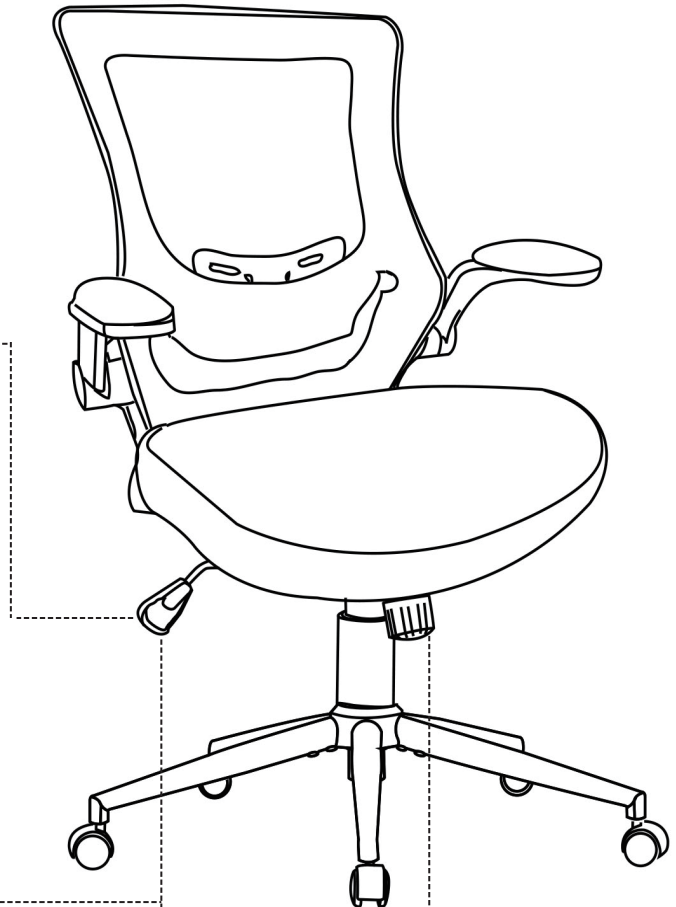

Note: If adjusting while sitting in chair:  
Turn knob left to tighten tension.  
Turn knob right to loosen tension.



# Y14249 CHAIR

## Functionity

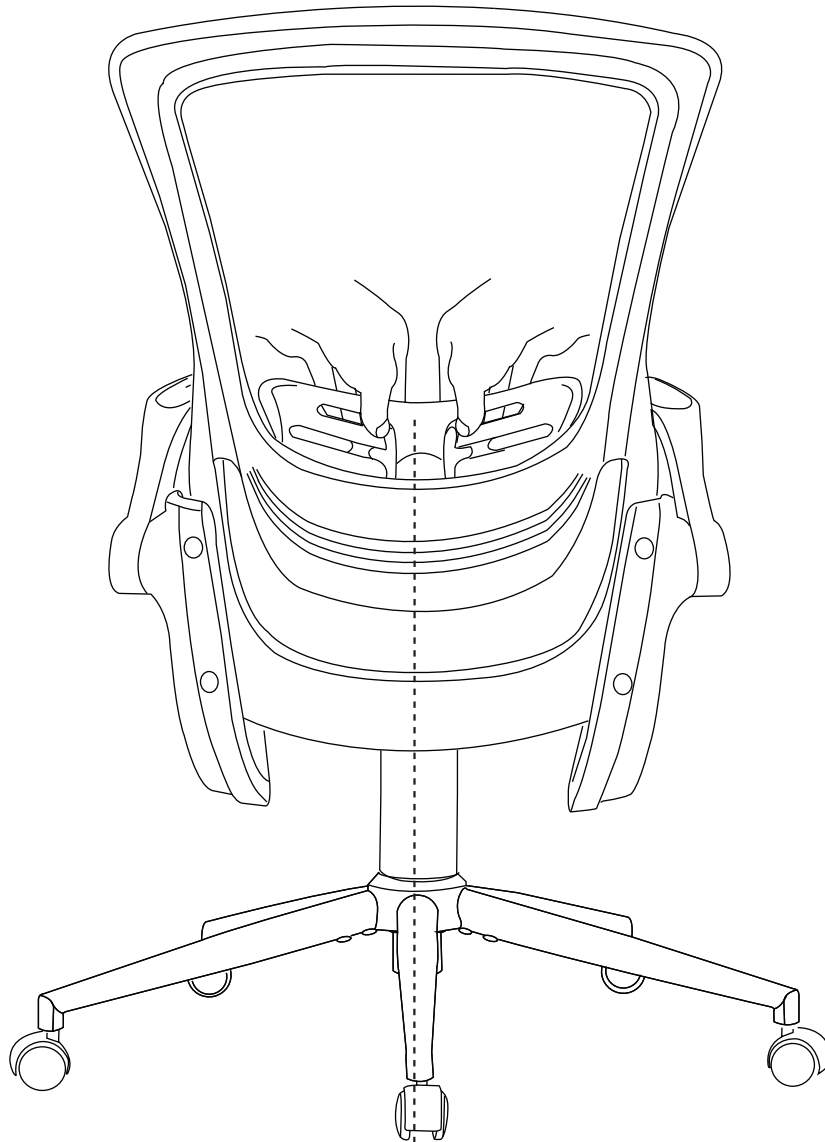

**\* Adjustable Lumbar Support**

-To adjust lumbar support up or down,  
sit in the chair and reach behind with both  
hands,raise or lower support to required  
comfort level.