

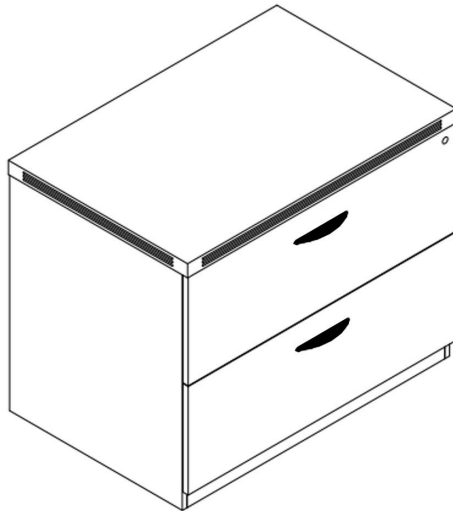



2, 3 & 4 Drawer Lateral File Assembly Instructions

Applies towards:

BK/FL/MJ/ML/WH2012
WH2012A
LF3622-MWAL
LF3622-WH
WH2012A-3DLF
FL/MJ/ML/WH2012B

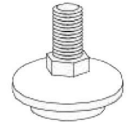

List of Hardware:

Part	Part
<p>Drawer Pull Screw</p>  <p>2 per drawer pull</p>	<p>Drawer Pull</p>  <p>1 per drawer</p>
 <p>1 set of keys</p>	 <p>4 Leveling Glides</p>

1.) Install 4 leveling glides. Keep the front two leveling glides 1/4" taller than the back back two, which means your file will be slightly tilted back. This is the proper way to level a lateral file cabinet. It keeps any unlocked file drawers from creeping open and distributes the weight more evenly.

2.) Use the screws to attach drawer pulls.

Questions? Please call 1-800-443-5117.
Customer Service available 8:30 - 5:00 Central Time, Monday - Friday

Bookcase Hutch Assembly Instructions



FL/MJ/ML/WH2050

List of Hardware:



1.) Screw in/insert all cam pins, cam locks and wood dowels in both side panels, fixed shelf and top surface.

2.) Assemble the unit on its side, on carpet or cardboard to protect it during assembly. Begin by attaching the Back Panel to one of the Side Panels. The cam pins and dowels should fit into the holes on the edge of the side panel. Use your screwdriver to twist the cam locks to secure the connection like shown in Figure 1.

3.) Next, attach the Fixed Shelf to the Side Panel and Back Panel using same method.

4.) Then, attach the opposite Side Panel to Fixed Shelf and Back Panel.

5.) Attach Top Surface.

Tools Needed:

-Phillips Screwdriver
-A Helper

Special Note:

Location & number of cam pin, cam lock and dowel holes may vary.

Figure 1

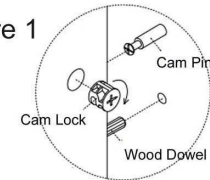

Exploded diagram of parts

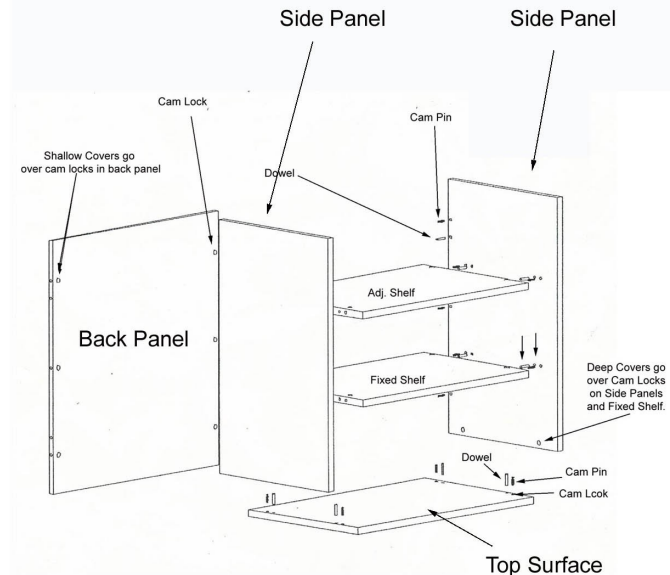

6.) With a helper, turn the unit upright. Double-sided tape is pre-applied to the bottom of the left and right side panels. To secure your unit to the file or cabinet that this will sit upon, peel off the backing and carefully set the unit on top. The tape will hold and secure the hutch.

7.) Insert the shelf pins into your desired position and set the Adjustable Shelf on top of the pins to mount.

8.) Insert shallow covers to cover the cam locks on the Back Panel and the deep covers to cover the cam locks on the Side Panels.

Questions? Please call 1-800-443-5117.

Customer Service available 8:30 - 5:00 Central Time, Monday - Friday

4-Door Cabinet Assembly Instructions

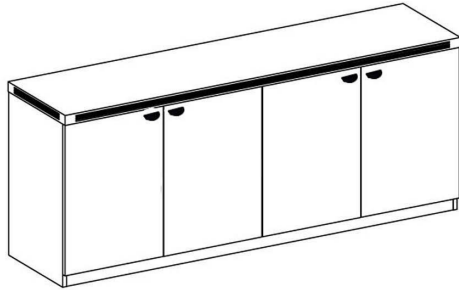

Applies Towards:

BK/CH/FL/MJ/ML/WH2051A











Tools Needed:

- Phillips Screwdriver
- A Helper

Special Note:

Location & number of cam pin, cam lock and dowel holes may vary.

List of Hardware:

 Wood Dowel	 Shelf Pin	 Hinge
 Cam Pin	 Plunger Lock	 Hinge Plate
 Cam Lock	 Leveling Glide	 Lock/Key
 Door Pull	 Shallow Cover	 Deep Cover

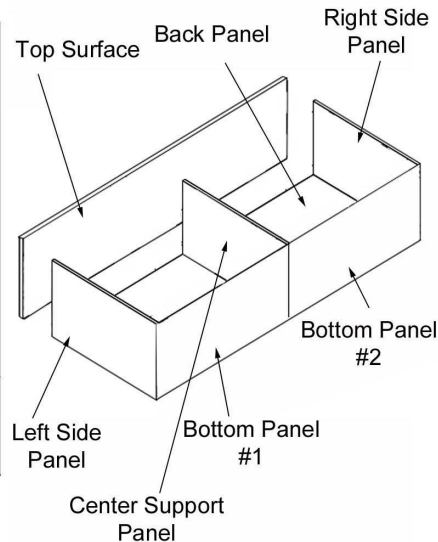

Questions? Please call 1-800-443-5117.

Customer Service available 8:30 - 5:00 Central Time, Monday - Friday

- 1.) Lay out all of the panels on a carpeted surface or on cardboard to protect during assembly. Insert all cam pins, cam locks and dowels into holes. Insert all 6 leveling glides into the Left & Right Side Panels and Center Support Panel.
- 2.) Attach the Center Support Panel to the Back Panel first, twisting the cam locks down with a Phillips Screwdriver to secure the connection.
- 3.) Next, attach Bottom Panel #1 and the Left Side Panel to Back Panel and Center Support Panel. You may need a helper to hold panels while another attaches.
- 4.) Repeat the process for Bottom Panel #2 and Right Side Panel.
- 5.) Attach Top Surface. The shell of the credenza is now complete. With a helper, carefully turn the unit upright.
- 6.) Insert 4 shelf pins per side and set the Shelves on top of the pins.
- 7.) Connect door pulls to the doors with screws provided, two screws per pull.
- 8.) Next, connect all 8 Hinge Plates to the inside of the credenza. The holes for are piloted. DO NOT TIGHTEN ALL OF THE WAY YET! Leave wiggle room for the upcoming steps.
- 9.) Attach the hinges to the doors. The inside doors will use the 'flat' hinges. The outer doors will have the hinges with the 'bump'. Once all are attached, slide the hinges onto the hinge plates inside the credenza and connect the hinges with the screws.
- 10.) The next step is to align the doors. Using your screwdriver, turn the set screw on the hinge to adjust the depth and the screws on the hinge plate to move the door up/down. Once aligned, you can tighten the hinges plates down all of the way.
- 11.) Insert covers over cam locks.
- 12.) Install Plunger Locks on each Left Side Door. Align the locks so that the plunger will insert into predrilled hole on underside of top surface when activated. Install Locks into right side doors using screws provided.

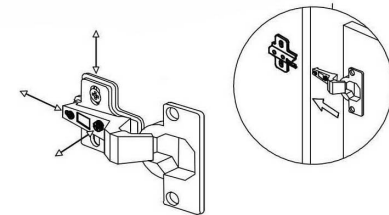
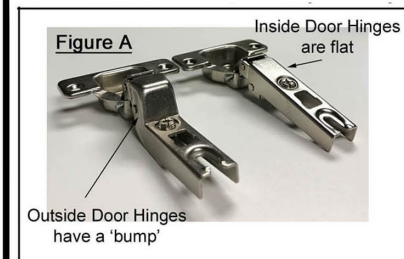

4-Door Hutch Assembly Instructions

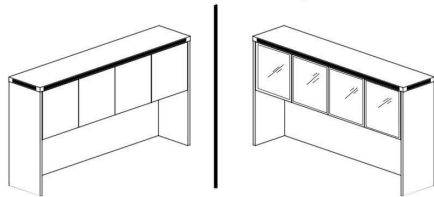









Applies to:
BK/CH/FL/MJ/ML/WH2044
MJ2025-CHL

Questions? Please call 1-800-443-5117.

Customer Service available 8:30 - 5:00 Central Time, Monday - Friday

List of Hardware:

Part	Part	Part
 Wood Dowel	 Cam Lock Cap	Qty 4  Outside Door Hinge
 Cam Pin		Qty 4  Inside Door Hinge
 Cam Lock	 Grommet	Qty 8  Hinge Plate

Tools Needed:

- Phillips Screwdriver
- A Helper

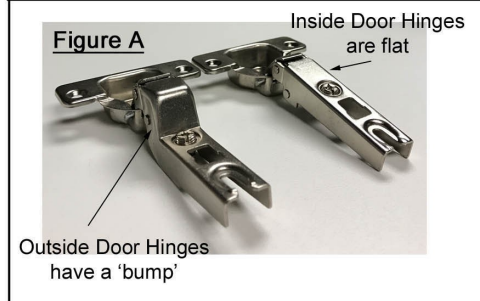

- 1.) Locate the Back Panel, Left & Right Side Panels and Center Shelf. Insert all wooden dowels, cam pins and cam locks. Connect Back Panel to the Center Shelf. Then connect the Left Side Panel, then Right Side Panel. Once all panels are connected, use your screwdriver to twist the cam locks to secure the connections.
- 2.) Connect the Middle Support Panel in same method.
- 3.) Attach Top Surface in same method.
- 4.) Attach all 8 Hinge Plates to the inside walls of the hutch. Use two per door. The holes are piloted. **DO NOT TIGHTEN DOWN THE SCREWS ALL OF THE WAY. LEAVE WIGGLE ROOM!**

Special Note:

Location & number of cam pin, cam lock and dowel holes may vary.

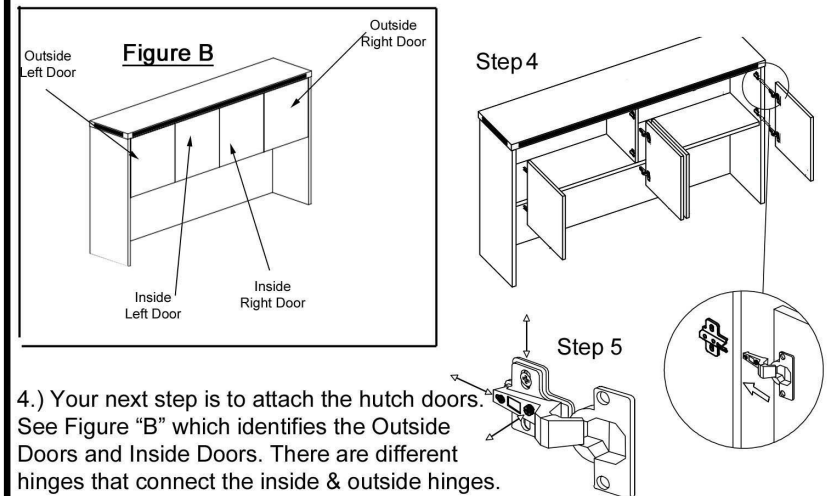
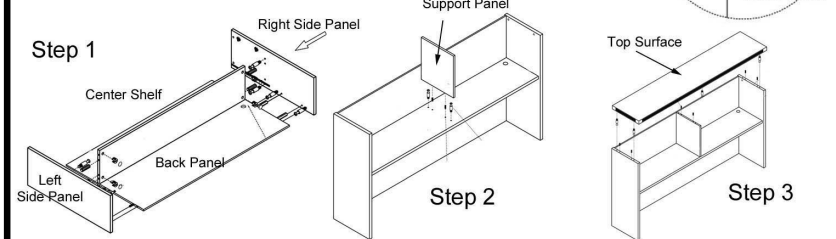

- 4.) Your next step is to attach the hutch doors. See Figure "B" which identifies the Outside Doors and Inside Doors. There are different hinges that connect the inside & outside hinges. See Figure "A" to help identify. Attach two hinges per door. Use the hinges with the 'bump' on the Outside Left & Right Doors and the flat hinges on the Inside Left & Right Doors. The holes are piloted. Use the screws provided. Once the hinges are attached, slide the hinges over the Hinge Brackets, fitting the screw head of the Hinge Bracket in the slot of the Hinge. Once fitted, slightly tighten the set screw. Now, set your hutch on your desk. Use the double-sided tape to securely adhere to desktop.
- 5.) Next, it is time to adjust the doors so that they properly align. Using your screwdriver, turn the Set Screw on the hinge to adjust the depth and the screws on the hinge plate to move the door up/down.
- 6.) Last step is to install Cam Lock Caps and Grommet cover.

Video on Hinge Door Adjustment available at link:
<http://www.modernofficefurniture.com/office-furniture-assembly-instructions.html>

"How to Adjust Hinges on 4-Door Hutch"

66"H Storage Cabinet Assembly Instructions

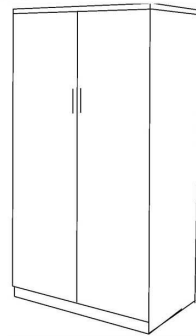











Applies Towards:

FL/MJ/ML/WH2051

Tools Needed:

- Phillips Screwdriver
- A Helper

List of Hardware:

 Wood Dowel	 Shelf Pin	 Hinge
 Cam Pin	 Plunger Lock	 Hinge Plate
 Cam Lock	 Leveling Glide	 Lock/Key
 Door Pull	 Shallow Cover	 Deep Cover

Special Note:

Location & number of cam pin, cam lock and dowel holes may vary.

1.) Insert all hardware into both Side Panels, Back Panel, Top, Bottom Shelf and Toe Kick. Then, start with one of the Side Panels. Lay the Side Panel on cardboard or carpet to protect during assembly. Attach Fixed Shelf with the cam lock/pin hardware. Use your screwdriver to twist the round cams to lock the pin.

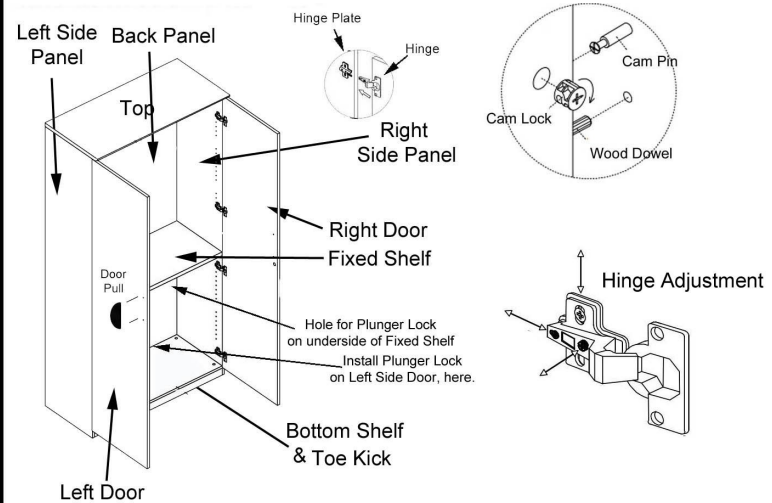

2.) Attach the Bottom Shelf to the Side Panel in same manner. Then attach the Toe Kick to the Bottom Panel.

3.) Next, attach the Back Panel to the Side Panel, Fixed Shelf and Bottom Shelf.

4.) Now, attach the other Side Panel.

5.) Next, insert all Leveling Glides into the bottom of the of the cabinet.

6.) Connect Top Surface. Once fixed, turn the cabinet upright with a helper.

7.) Insert all shelf pins and mount the Adjustable Height Shelves.

8.) Next, attach 8 Hinge Plates. The holes are piloted along the inside of the Side Panels. **DO NOT FULLY TIGHTEN! LEAVE WIGGLE ROOM FOR ADJUSTING LATER ON!**

9.) Attach 4 Hinges on each door. Then, connect the doors by sliding the Hinges into the Hinge Plates, then screw down partially.

10.) Align doors by using the screws on the Hinge as shown above. Once aligned, fully tighten down Hinge Plates and Hinges.

11.) Mount Plunger Lock on Left Side Door with four screws as shown.

12.) Attach Door Pulls and Covers over cam locks.

Video on Hinge Door Adjustment available at link:

<http://www.modernofficefurniture.com/office-furniture-assembly-instructions.html>

"How to Adjust Hinges on 4-Door Hutch"

Questions? Please call 1-800-443-5117.

Customer Service available 8:30 - 5:00 Central Time, Monday - Friday

