

Y12687 -Y12789 Pneumatic Sit-Stand Tilt & Roll Table Assembly Instructions

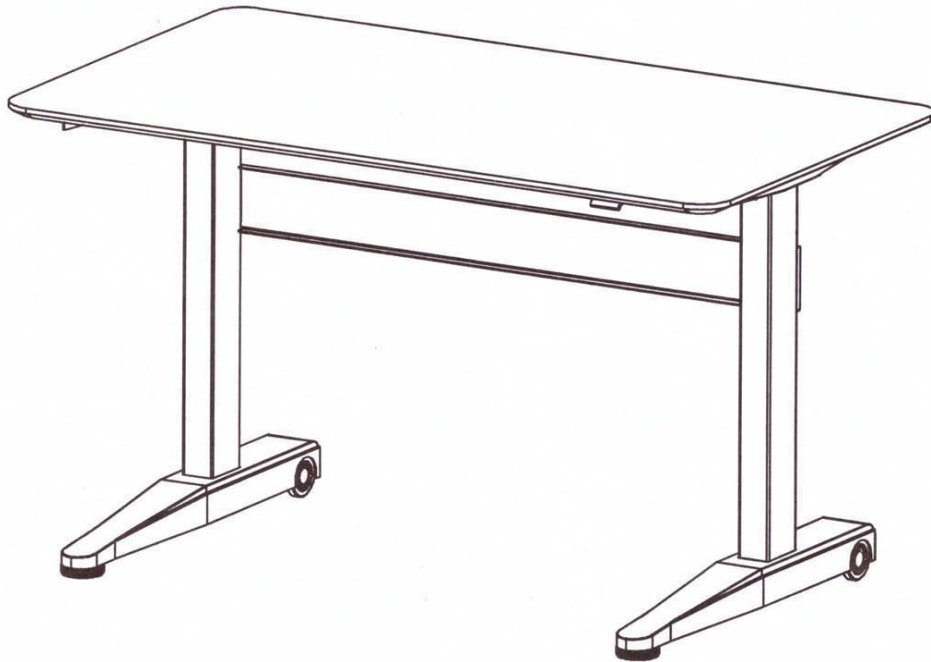

**Questions? Please call 1-800-443-5117.
Customer Service available 8:30 - 5:00 Central Time, Monday - Friday**

Tools Needed:

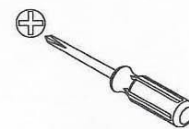

Power Screwdriver or a Phillips Screwdriver

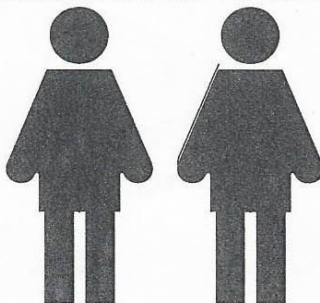

-Desktop may need to be pulled up to raise in cooler offices and environments.

-Potential tip hazard: Do not misuse. Supervise nearby children.

Y12687 -Y12789 Pneumatic Sit-Stand Tilt & Roll Table Assembly Instructions

Find our assembly video under "Assembly Instructions" on our website or at the link below:

<https://bcove.video/2VQGBEk>

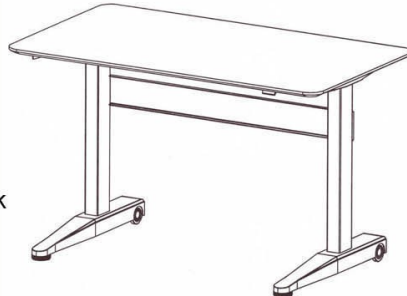

Tools Needed:

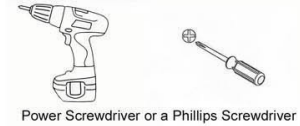

Power Screwdriver or a Phillips Screwdriver

Questions? Please call 1-800-443-5117.

Customer Service available 8:30 - 5:00 Central Time, Monday - Friday

List of Parts:

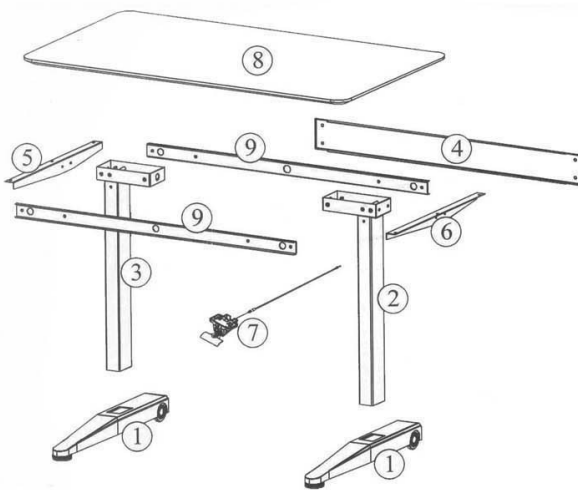

- | | |
|----------------------------|-----------------------------|
| 1 - Foot | 6 - Right Table Top Support |
| 2 - Right Leg | 7 - Paddle/Pneumatics |
| 3 - Left Leg | 8 - Table Top |
| 4 - Front Brace | 9 - Cross Beam |
| 5 - Left Table Top Support | |

List of Hardware:

- A Leveling Glides x 2
- B M6x12mm Bolt x 12
- C M6x25mm Bolt & Washer x 8
- D M8 x10mm Bolt & Washer x 4
- E Wood Screws for Table Top and Paddle x 8
- F Allen Wrench x 1
- G Wrench x 1
- H Cable Clamp x 3
- I Wood Screw for Cable Clamps

To use: Once assembled, squeeze paddle to raise the table top. To lower, squeeze paddle and push down with your free hand or arm. To roll, tilt the table onto the caster side of the base.

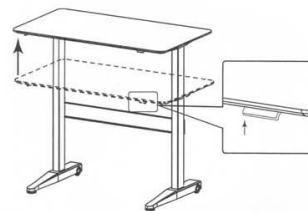

List of Hardware:

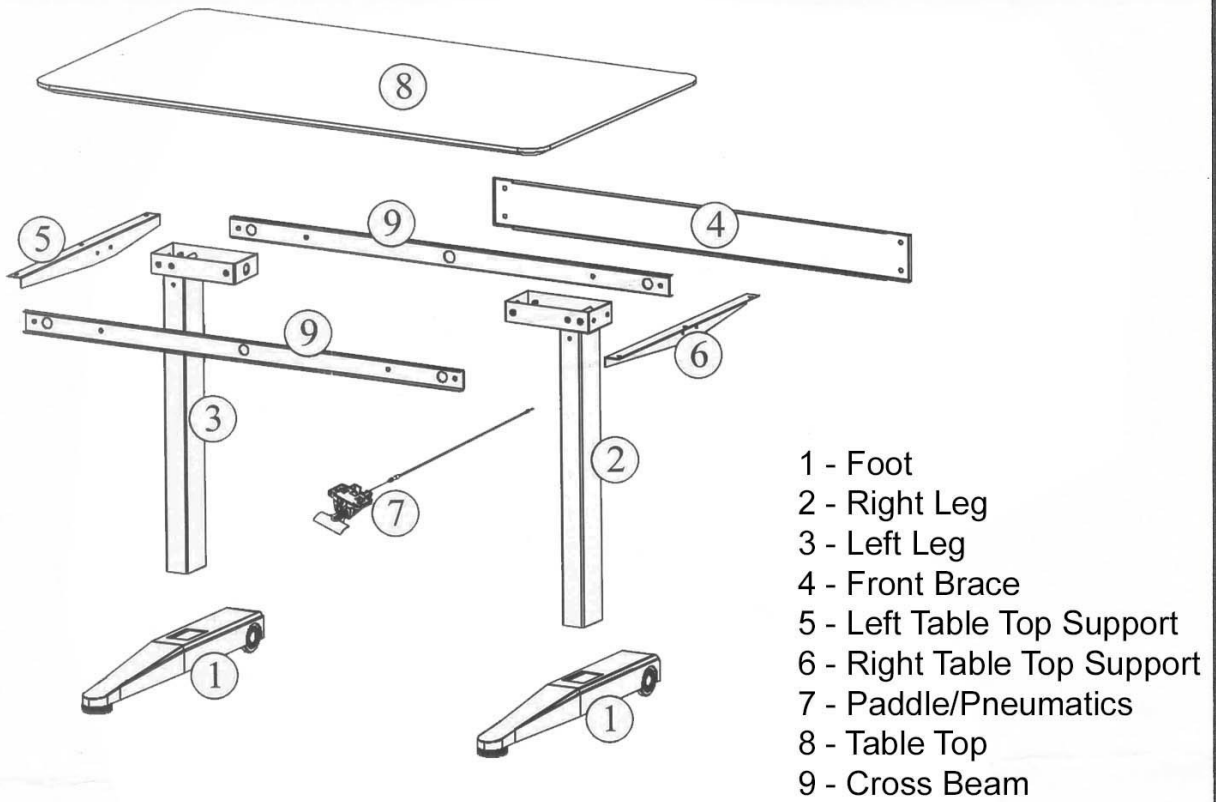

List of Hardware:

- | | | | | | |
|---|---|--|---|--|-----------------------------|
| A |  | Leveling Glides x 2 | F |  | Allen Wrench x 1 |
| B |  | M6x12mm Bolt x 12 | G |  | Wrench x 1 |
| C |  | M6x25mm Bolt & Washer x 8 | H |  | Cable Clamp x 3 |
| D |  | M8 x10mm Bolt & Washer x 4 | I |  | Wood Screw for Cable Clamps |
| E |  | Wood Screws for Table Top and Paddle x 8 | | | |

Step 1.) Insert "A" Leveling Glides into both Feet.

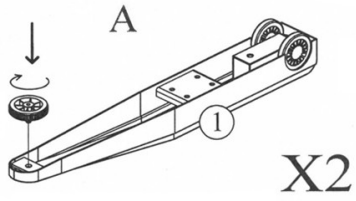

Step 2.) Use the "F" Allen Wrench and "D" screws and washers to attach Front Brace to both Legs. LEAVE SCREWS LOOSE FOR NEXT STEP! DO NOT FULLY TIGHTEN!

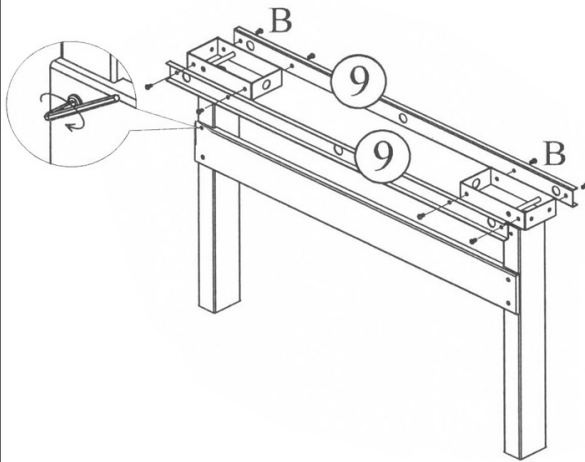
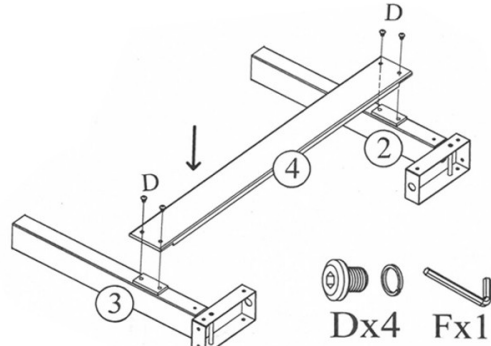

Step 3.) Use the "F" Allen Wrench to attach both Cross Beams with the "B" Screws. Then, fully tighten all screws, including those from the previous step.

Step 4.) Use the "F" Allen Wrench to attach the Feet to the Legs with the "C" Screws and Washers.

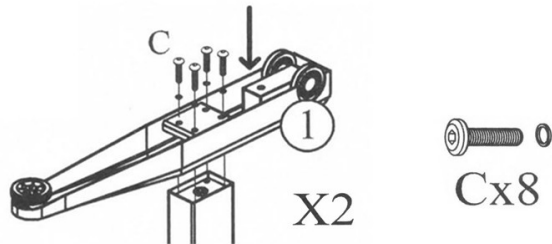

Step 5.) Attach Left and Right Side Table Top Supports using "F" Allen Wrench and "B" Bolts.

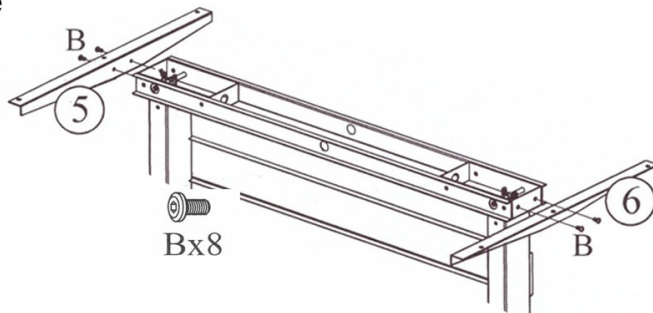

Step 1 Insert "A" Leveling Glides into both feet.

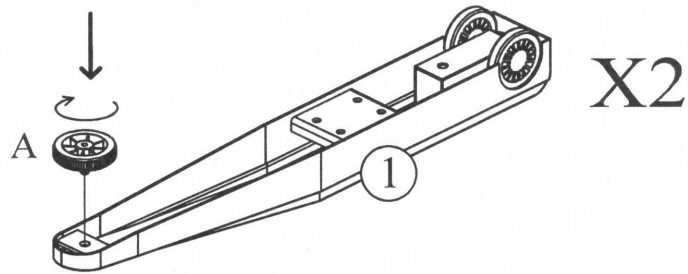

Step 2 Use the "F" Allen Wrench to attach the Front Brace to both Legs using "D" screws and washers.

DO NOT FULLY TIGHTEN SCREWS! LEAVE LOOSE FOR THE NEXT STEP!

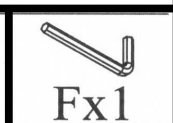
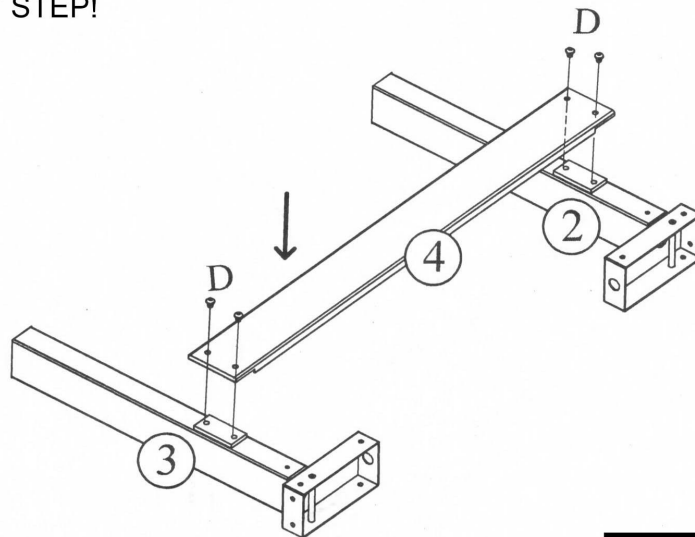

Step 6.) Insert the cables as shown in the diagrams below. Leave the nuts slightly loose.

Now it is time to adjust the pneumatic cables on your table frame. This step is essential to the operation of the desk. Make sure the threaded ends of the cables are pulled through the bracket towards the center of the desk, as far as they can go. Then, use the “G” Wrench to tighten, once you have tested it to make sure the frame moves up/down.

See our video detailing this step at <https://bcove.video/2VQGBEk>

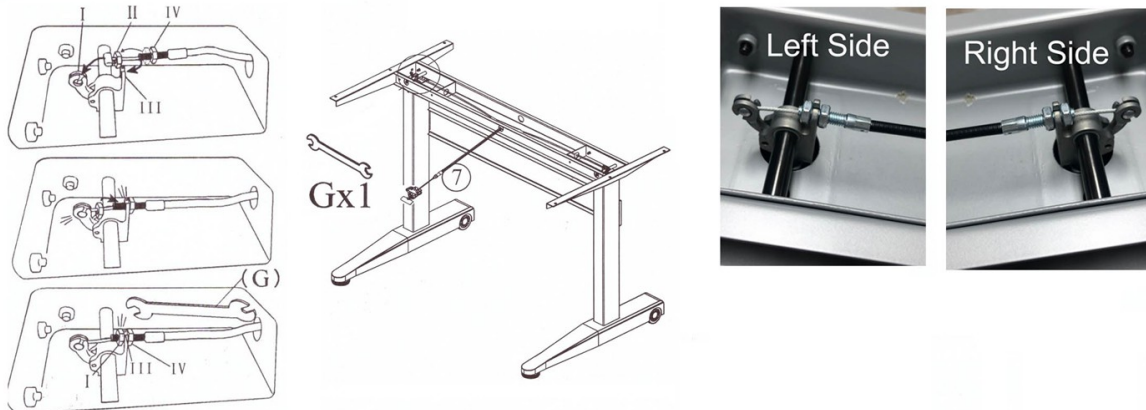

Step 7.) The next step is to attach the table top to the frame. Flipping the frame upside down is optional, but easier to assemble this way. Center the table top on the frame. Using a power Phillips screwdriver, use the “E” Wood Screws to drill through the holes in the frame into the underside of the table top. Use three screws on each side, for a total of 6. Once your table top is attached, use two additional “E” Wood Screws to attach the paddle to the underside of the top, along the edge, on either the left or right side. This step is also shown in our video referenced above.

Special Note There are no piloted holes for attaching the table top or paddle. The “E” screws are self-drilling so you are making your own holes. You may see threaded inserts on your table top. Please disregard those as those are not for attaching this desk frame.

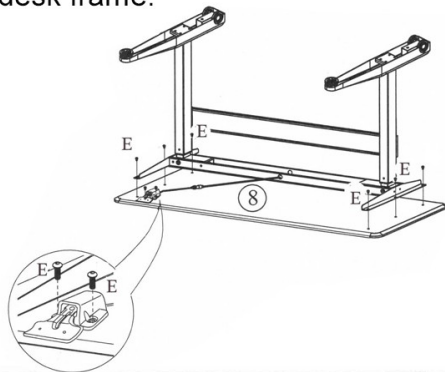

Step 8.) The last step is to attach the “H” cable clamps to the underside of the table top. Use the self-drilling “I” Wood Screws.

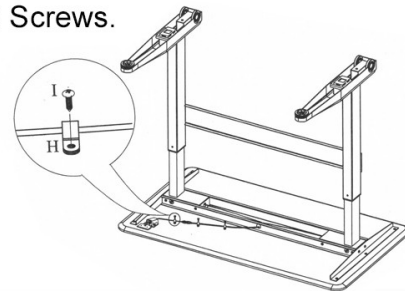

Step 3 Use the "F" Allen Wrench to attach the Rear and Front Cross Beams with the "B" Bolts. Then fully tighten all screws, including the ones from the previous step.

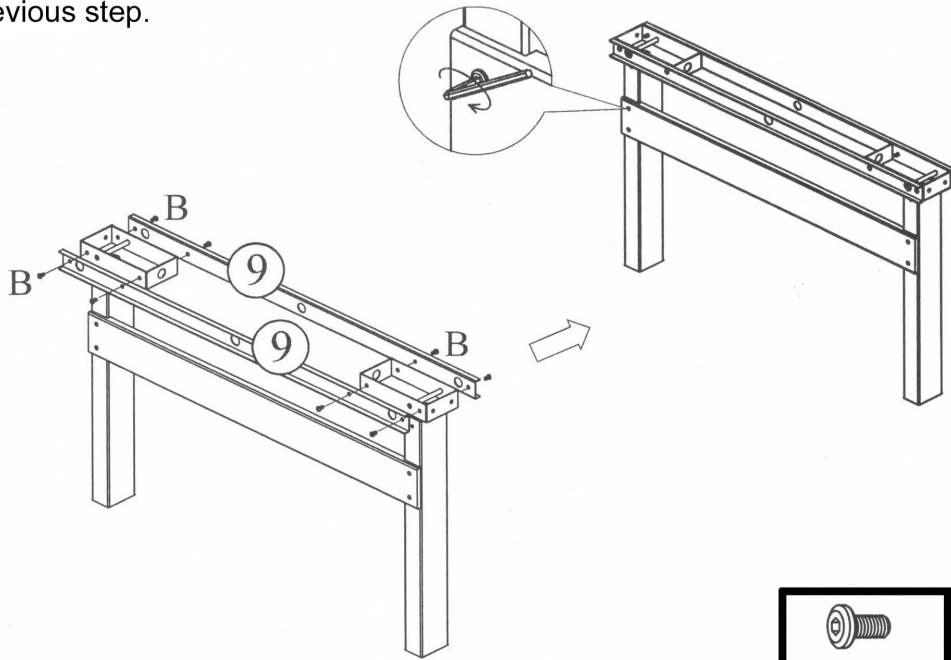

Step 4 Attach the Feet to the Legs using the "F" Allen Wrench and "C" Bolts and washers.

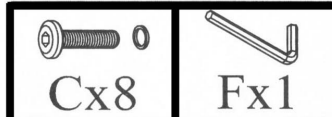
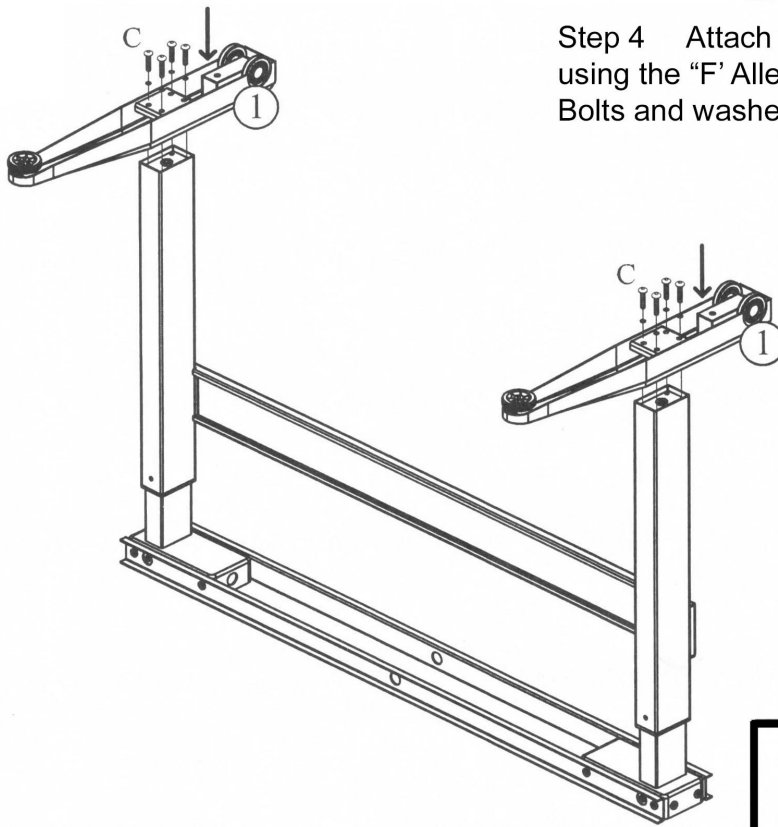

Step 5 Attach Left and Right Side Table Top Supports using "F" Allen Wrench and "B" Bolts.

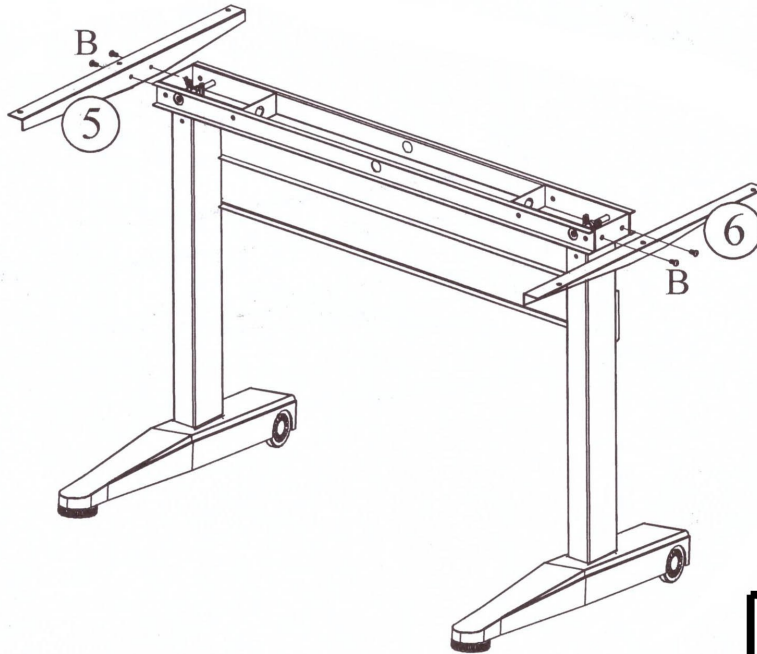

Bx4



Fx1

Step 6 Insert the cables as shown in the diagrams below. Leave the nuts slightly loose.

Now it is time to adjust the pneumatic cables on your table frame. This step is essential to the operation of the desk. Make sure the threaded ends of the cables are pulled through the bracket towards the center of the desk, as far as they can go. Then, use the "G" Wrench to tighten, once you have tested it to make sure the frame moves up/down.

See our video detailing this step at <https://bcove.video/2VQGBEk>

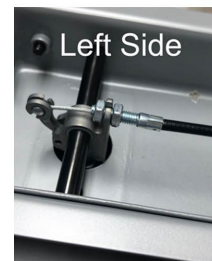
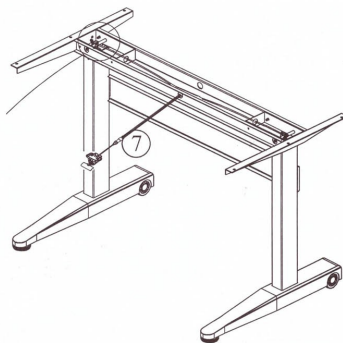
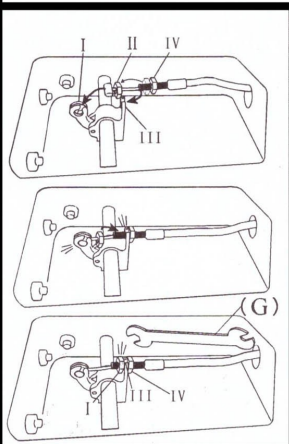

Gx1

Step 7 Now it is time to attach the table top to the frame. Flipping the frame upside down is optional, but is easier for some to assemble this way. Center the table top on the frame. Using a power or Phillips screwdriver, use the “E” wood screws to drill through the frame into the top. Use three screws per side, total of six.

Note There are no predrilled holes for this step. The “E” wood screws are ‘self-drilling’ so you will be making your own holes. Sometimes you may see threaded inserts in the underside of the top. Those holes are not used for assembly of this frame.

Once your table top is attached, use two “E” screws to attach the paddle to the underside of the top, by the table edge, in your preferred spot.

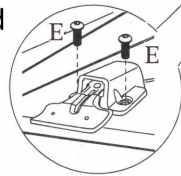
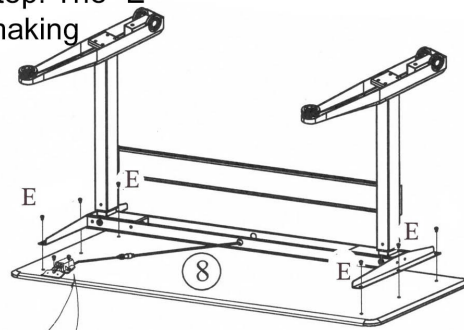

Ex1

Step 8 The last step is to connect the “H” cable clamps to the underside of the top. Use the “I” self-drilling wood screws to attach the clamps.

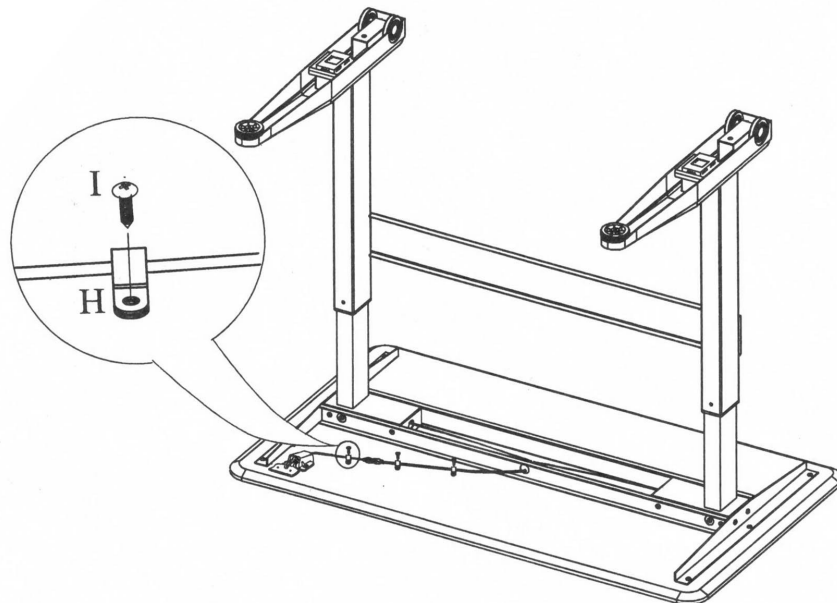

Hx3

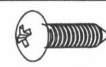

Ix3

OPERATING MANUAL

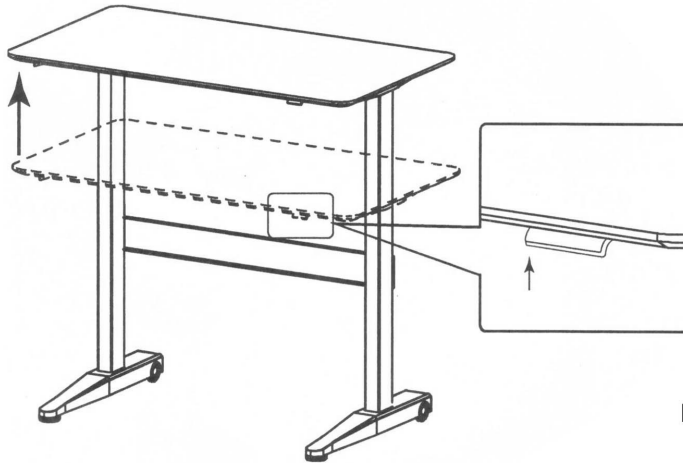

Very simple to use!
Squeeze the paddle to
raise the table top to your
preferred height.

Desktop may need to be manually
pulled up in cooler environments

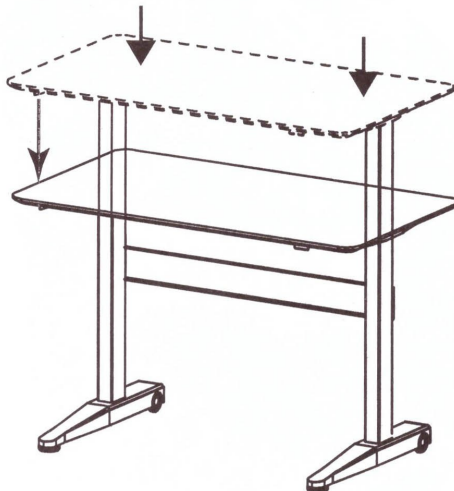



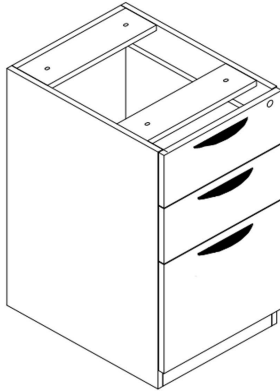

To lower, squeeze the paddle
and push down with your arm
or hand.

Box/Box/File Desk Pedestal Assembly Instructions

Applies towards:
BK/CH/FL/MJ/ML/WH2066



List of Hardware:

Part	Part
 4 Large Bolts	 3 Drawer Pulls with screws
 1 set of keys	 4 Leveling Glides

- 1.) Install 4 leveling glides.
- 2.) Use the screws to attach drawer pulls.
- 3.) To install under desk, remove the top box drawer (or top two box drawers) by locating the black tabs inside of the left & right drawer slides. Push down on one and push up on the other. This will release the drawer from the slides. Use 4 large bolts to connect to threaded holes on underside of desk. Once done, simply insert drawers back into the slides. They will snap in place.

Questions? Please call 1-800-443-5117.
Customer Service available 8:30 - 5:00 Central Time, Monday - Friday

Reversible Desk Return Assembly Instructions

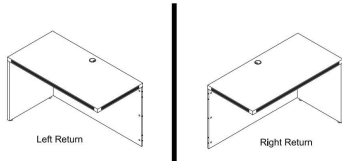

Applies to:
BK/CH/FL/MJ/ML/WH2045

List of Hardware:

Part	Part	Part

Tools Needed:

- Phillips Screwdriver
- Power Screwdriver
- A Helper

- 1.) Assemble on carpet or cardboard to protect parts during assembly. Assembly will require 2 people for safety.
- 2.) Determine if the return will be left or right handed (see diagram next page). Locate Side Panel & End Panel and arrange like shown in drawing. Insert leveling glides, then insert all cam pins, cam locks and wood dowels. Then connect the panels by inserting the dowels into the holes on opposite panel and inserting cam pins into cam locks (see diagram). Then, twist the cam locks with a Phillips Screwdriver to secure connection.
- 3.) Next, locate the Desktop and insert hardware. Then, set the desktop on the lower assembly and twist cams to securely connect.

Special Note:

Location & number of cam pin, cam lock and dowel holes may vary.

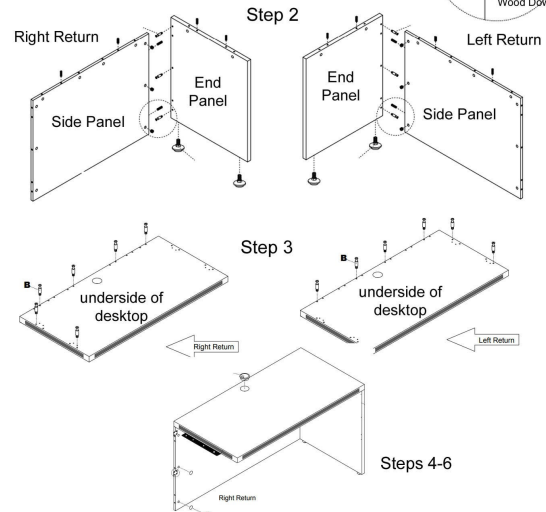
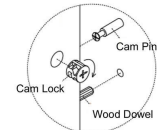

- 4.) Now it's time to attach the return to your desk. Locate the large flat bracket and M6 machine screws (it may be attached to the desktop already. If not, center the bracket over the edge and install 4 of the screws). With a helper, have one person hold the return desk stable while the other screws the machine screws into the desk.
- 5.) Once installed & leveled, use the wood screws to install the offset side panel brackets. This will further secure the side panel, but is an optional step. A power screwdriver is helpful.
- 6.) Lastly, insert the grommet into the desktop and use the caps provided to cover the cam locks.

Questions? Please call 1-800-443-5117.

Customer Service available 8:30 - 5:00 Central Time, Monday - Friday





Modern Office
8900 Shady Oak Road, Ste 120
Eden Prairie, MN 55344
Phone: 800.443.5117
(in MN): 952.941.2837
Fax: 952.949.9816
www.modernofficefurniture.com

Reversible Desk Return CH/FL/MJ/ML/MWAL/WH2045B Half Panel

For installation on Electric Lift L-Desks
with non-adjustable returns.



Part
 Wood Screw
Qty 20
 Bracket
Qty 2
 Leveling Glide

ASSEMBLY INSTRUCTIONS

Questions? Please call 1-800-443-5117.
Customer Service available 8:30 - 5:00 Central Time, Monday - Friday

Half Panel placement shown in gray

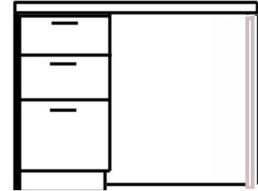
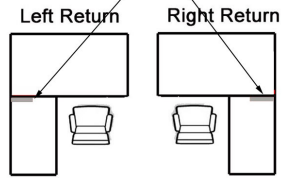

Tip: Make sure your drawer pedestal is connected to your return desk with the four bolts included with the file. If that does not stabilize the desk as desired, install this half panel for additional support.



1.) Screw in both leveling glides into Half Panel.

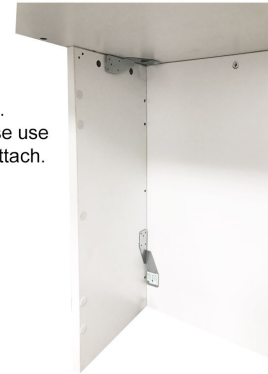

2.) Attach the Brackets as shown. There are no pilot holes, so please use the self-drilling wood screws to attach.