

Y12687 -Y12789 Pneumatic Sit-Stand Tilt & Roll Table Assembly Instructions

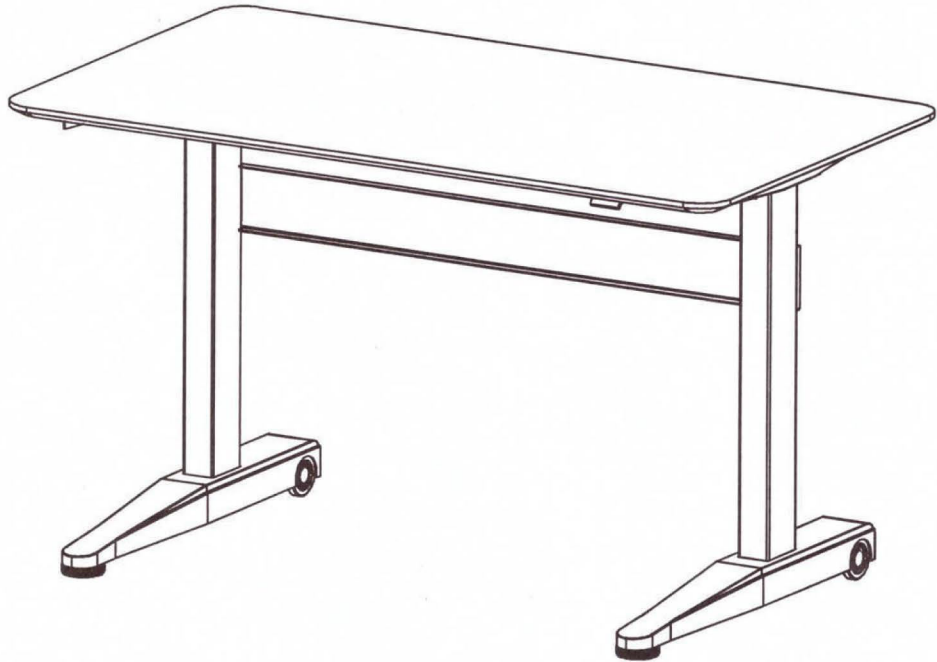

**Questions? Please call 1-800-443-5117.
Customer Service available 8:30 - 5:00 Central Time, Monday - Friday**

Tools Needed:

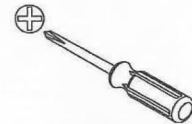

Power Screwdriver or a Phillips Screwdriver



-Desktop may need to be pulled up to raise in cooler offices and environments.

-Potential tip hazard: Do not misuse. Supervise nearby children.

Y12687 -Y12789 Pneumatic Sit-Stand Tilt & Roll Table Assembly Instructions

Find our assembly video under "Assembly Instructions" on our website or at the link below:

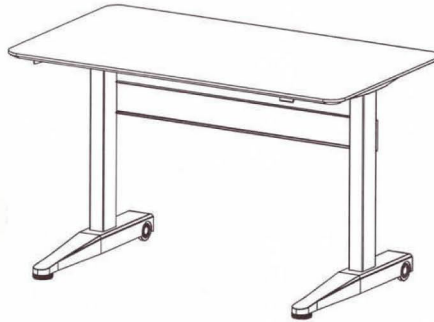

Tools Needed:

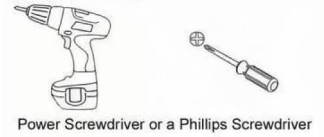

Power Screwdriver or a Phillips Screwdriver

Questions? Please call 1-800-443-5117.

Customer Service available 8:30 - 5:00 Central Time, Monday - Friday

List of Parts:

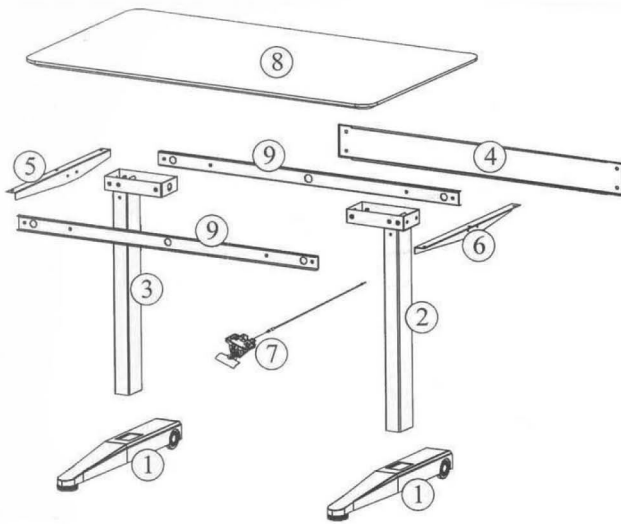

- 1 - Foot
- 2 - Right Leg
- 3 - Left Leg
- 4 - Front Brace
- 5 - Left Table Top Support
- 6 - Right Table Top Support
- 7 - Paddle/Pneumatics
- 8 - Table Top
- 9 - Cross Beam

List of Hardware:

- A Leveling Glides x 2
- B M6x12mm Bolt x 12
- C M6x25mm Bolt & Washer x 8
- D M8 x10mm Bolt & Washer x 4
- E Wood Screws for Table Top and Paddle x 8
- F Allen Wrench x 1
- G Wrench x 1
- H Cable Clamp x 3
- I Wood Screw for Cable Clamps

To use: Once assembled, squeeze paddle to raise the table top. To lower, squeeze paddle and push down with your free hand or arm. To roll, tilt the table onto the caster side of the base.

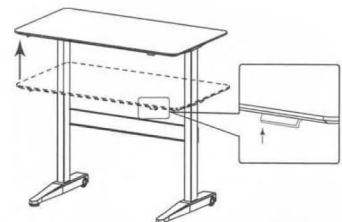

List of Hardware:

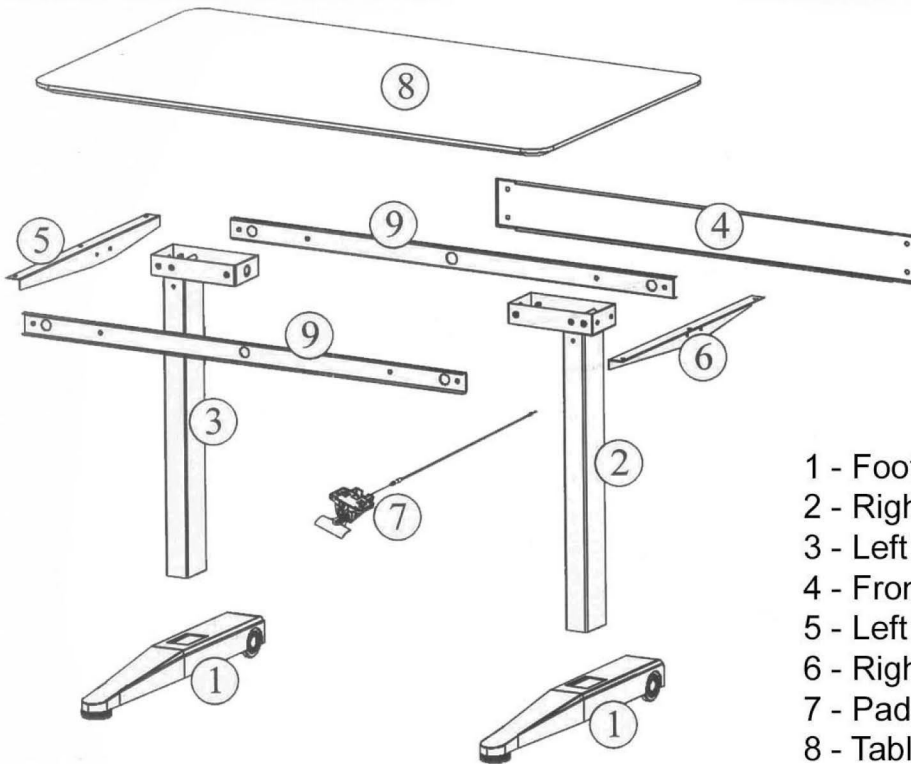

- 1 - Foot
- 2 - Right Leg
- 3 - Left Leg
- 4 - Front Brace
- 5 - Left Table Top Support
- 6 - Right Table Top Support
- 7 - Paddle/Pneumatics
- 8 - Table Top
- 9 - Cross Beam

List of Hardware:

- | | | | | | |
|---|---|--|---|---|-----------------------------|
| A |  | Leveling Glides x 2 | F |  | Allen Wrench x 1 |
| B |  | M6x12mm Bolt x 12 | G |  | Wrench x 1 |
| C |  | M6x25mm Bolt & Washer x 8 | H |  | Cable Clamp x 3 |
| D |  | M8 x10mm Bolt & Washer x 4 | I |  | Wood Screw for Cable Clamps |
| E |  | Wood Screws for Table Top and Paddle x 8 | | | |

Step 1.) Insert "A" Leveling Glides into both Feet.

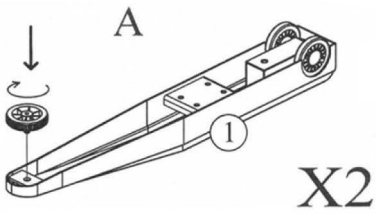

Step 2.) Use the "F" Allen Wrench and "D" screws and washers to attach Front Brace to both Legs. LEAVE SCREWS LOOSE FOR NEXT STEP! DO NOT FULLY TIGHTEN!

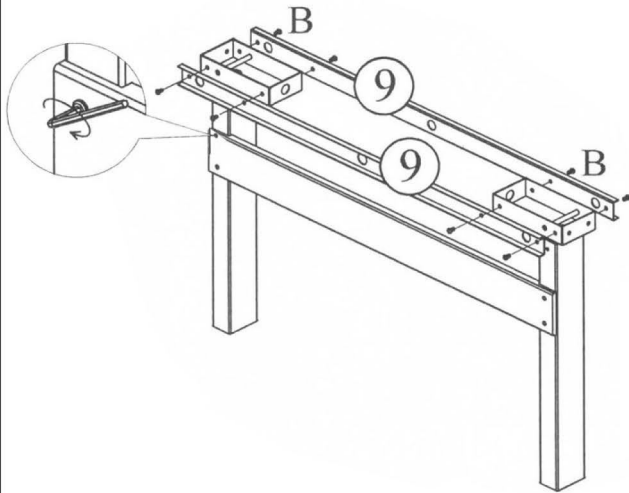
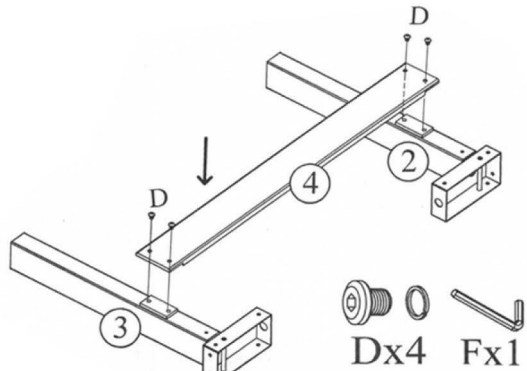

Step 3.) Use the "F" Allen Wrench to attach both Cross Beams with the "B" Screws. Then, fully tighten all screws, including those from the previous step.

Step 4.) Use the "F" Allen Wrench to attach the Feet to the Legs with the "C" Screws and Washers.

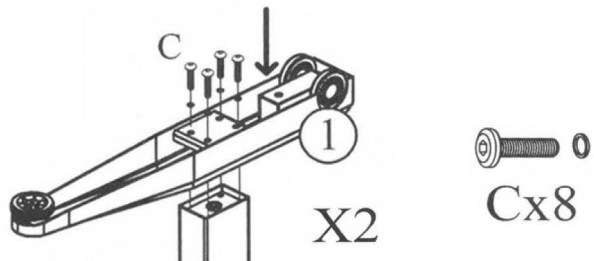

Step 5.) Attach Left and Right Side Table Top Supports using "F" Allen Wrench and "B" Bolts.

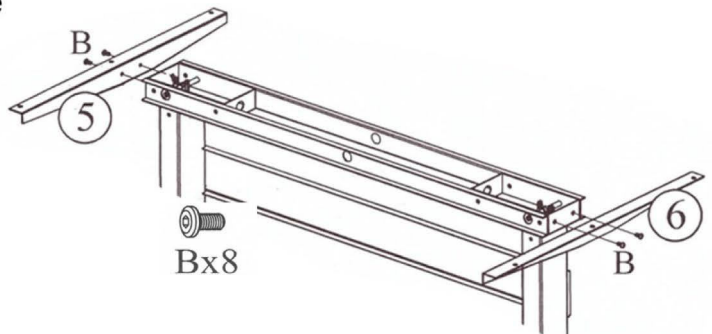

Step 1 Insert "A" Leveling Glides into both feet.

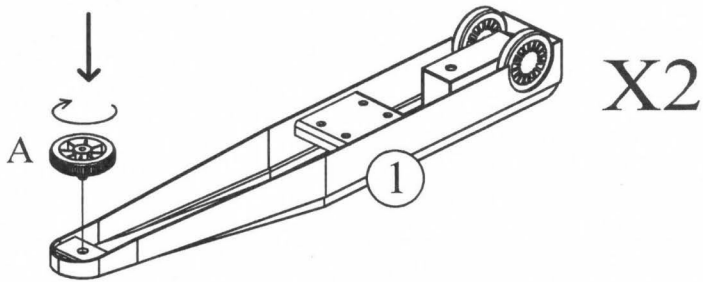

Step 2 Use the "F" Allen Wrench to attach the Front Brace to both Legs using "D" screws and washers.

DO NOT FULLY TIGHTEN SCREWS! LEAVE LOOSE FOR THE NEXT STEP!

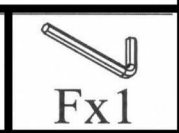
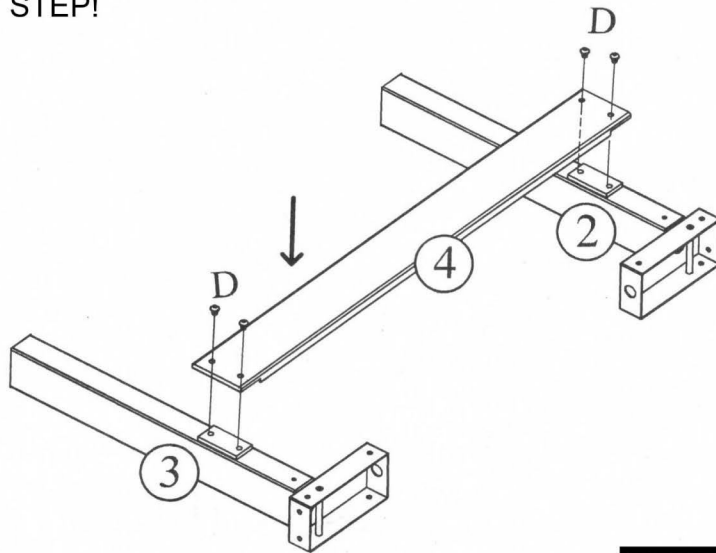

Step 6.) Insert the cables as shown in the diagrams below. Leave the nuts slightly loose.

Now it is time to adjust the pneumatic cables on your table frame. This step is essential to the operation of the desk. Make sure the threaded ends of the cables are pulled through the bracket towards the center of the desk, as far as they can go. Then, use the “G” Wrench to tighten, once you have tested it to make sure the frame moves up/down.



Step 7.) The next step is to attach the table top to the frame. Flipping the frame upside down is optional, but easier to assemble this way. Center the table top on the frame. Using a power Phillips screwdriver, use the “E” Wood Screws to drill through the holes in the frame into the underside of the table top. Use three screws on each side, for a total of 6. Once your table top is attached, use two additional “E” Wood Screws to attach the paddle to the underside of the top, along the edge, on either the left or right side. This step is also shown in our video referenced above.

Special Note There are no piloted holes for attaching the table top or paddle. The “E” screws are self-drilling so you are making your own holes. You may see threaded inserts on your table top. Please disregard those as those are not for attaching this desk frame.

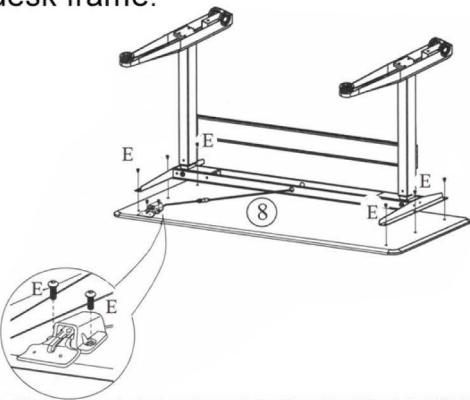

Step 8.) The last step is to attach the “H” cable clamps to the underside of the table top. Use the self-drilling “I” Wood Screws.

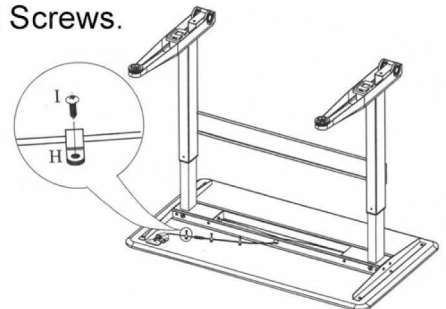

Step 3 Use the "F" Allen Wrench to attach the Rear and Front Cross Beams with the "B" Bolts. Then fully tighten all screws, including the ones from the previous step.

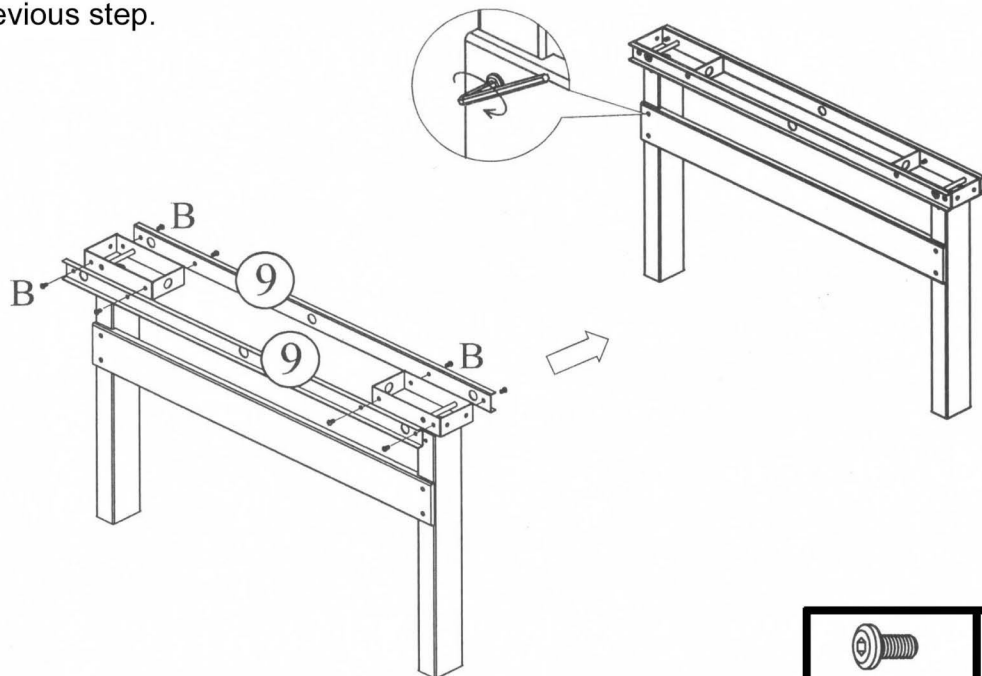

Step 4 Attach the Feet to the Legs using the "F" Allen Wrench and "C" Bolts and washers.

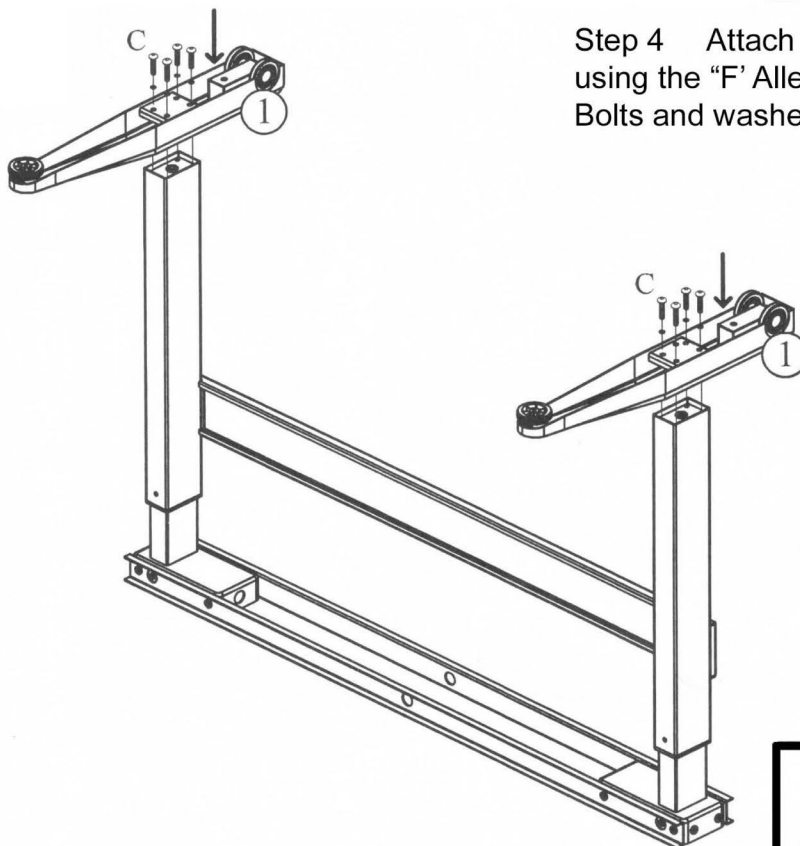

Step 5 Attach Left and Right Side Table Top Supports using "F" Allen Wrench and "B" Bolts.

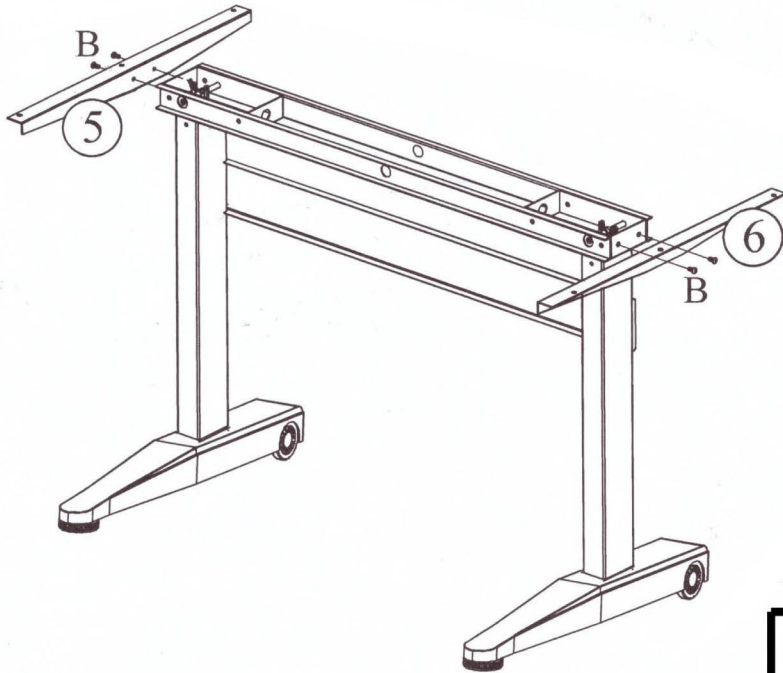

Step 6 Insert the cables as shown in the diagrams below. Leave the nuts slightly loose.

Now it is time to adjust the pneumatic cables on your table frame. This step is essential to the operation of the desk. Make sure the threaded ends of the cables are pulled through the bracket towards the center of the desk, as far as they can go. Then, use the "G" Wrench to tighten, once you have tested it to make sure the frame moves up/down.

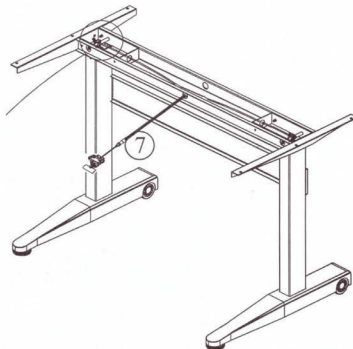
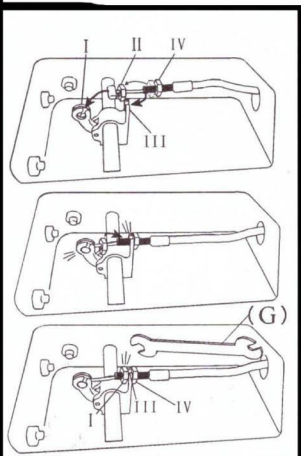

Step 7 Now it is time to attach the table top to the frame. Flipping the frame upside down is optional, but is easier for some to assemble this way. Center the table top on the frame. Using a power or Phillips screwdriver, use the “E” wood screws to drill through the frame into the top. Use three screws per side, total of six.

Note There are no predrilled holes for this step. The “E” wood screws are ‘self-drilling’ so you will be making your own holes. Sometimes you may see threaded inserts in the underside of the top. Those holes are not used for assembly of this frame.

Once your table top is attached, use two “E” screws to attach the paddle to the underside of the top, by the table edge, in your preferred spot.

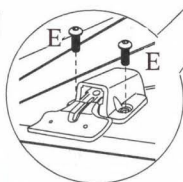
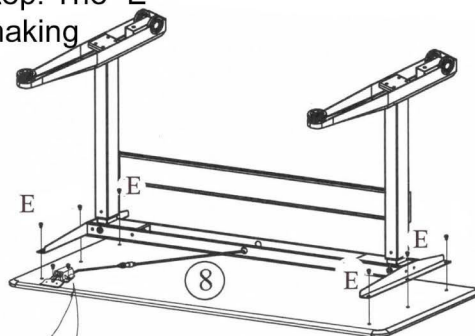

Ex1

Step 8 The last step is to connect the “H” cable clamps to the underside of the top. Use the “I” self-drilling wood screws to attach the clamps.

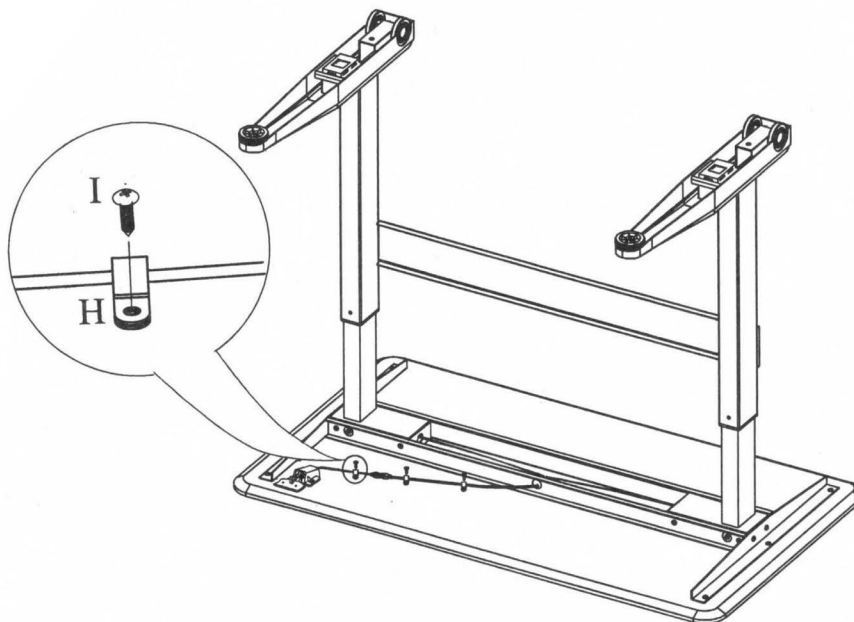

Hx3

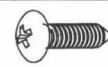

Ix3

OPERATING MANUAL

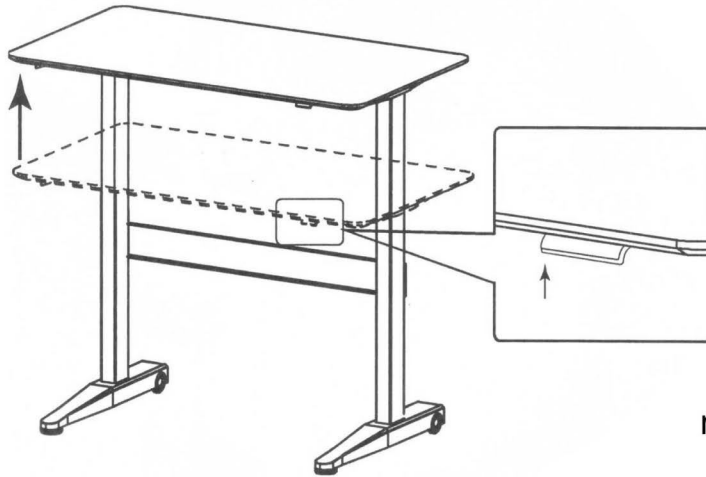

Very simple to use!
Squeeze the paddle to
raise the table top to your
preferred height.

Desktop may need to be manually
pulled up in cooler environments

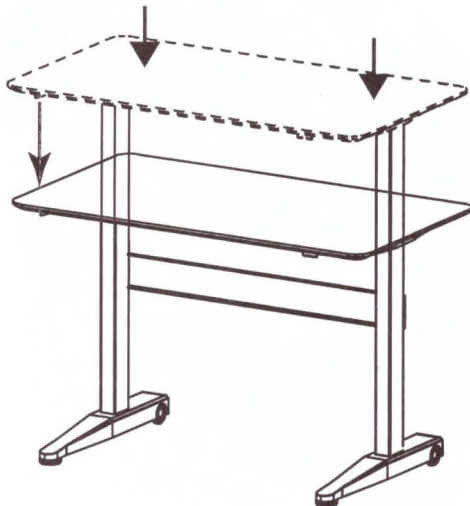

To lower, squeeze the paddle
and push down with your arm
or hand.

Reversible Bridge on Height Adjustable U-Workstation

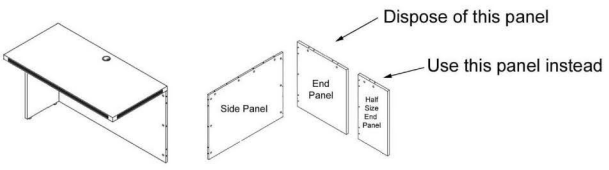

BK/CH/FL/MJ/ML/MWAL/WH2045 + 2045B

List of Hardware:

Part	Part	Part

- 1.) Assemble on carpet or cardboard to protect parts during assembly. Assembly will require 2 people for safety.
- 2.) Determine if the bridge will be Left or Right handed. Locate your Desktop, Side Panel and End Panel. In a separate box, you will find your Half Size End Panel. Dispose of the full size End Panel, as the Half Size End Panel will take its place.
- 3.) Insert all Leveling Glides on Side Panel and Half Size End Panel.
- 4.) Use the Cam Locks, Cam Pins and Dowels to connect the Half Size End Panel to the Side Panel.
- 5.) Then, attach the Desktop to the Side Panel and Half Size End Panel using the Dowels, Cam Locks and Cam Pins provided.

Tools Needed:

- Phillips Screwdriver
- Power Screwdriver
- A Helper

Box/Box/File Desk Pedestal Assembly Instructions

Applies towards:
BK/CH/FL/MJ/ML/WH2066

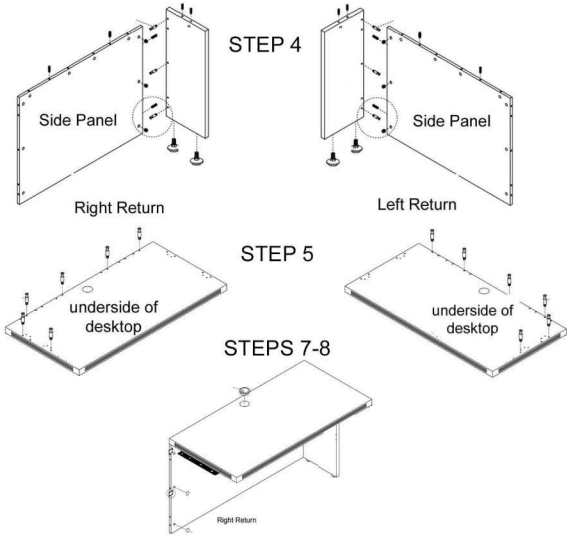
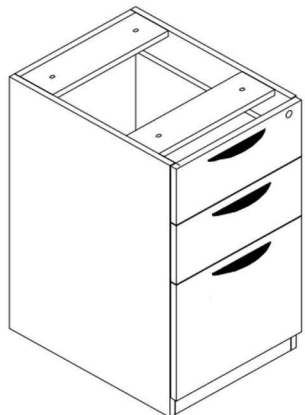

- 6.) Your next step is to make sure the desktop is level. This can be adjusted by screwing/unscrewing the leveling glides.
- 7.) Now it is time to place your bridge in between the assembled front desk and back desk. You will connect the bridge to the back desk using the Desktop Bracket and M6 machine screws. Then, connect the Side Panel to the Side Panel of your back desk using the Side Panel Brackets and Wood Screws.
- 8.) Your last step is to insert the Grommet into the desktop and use the Shallow and Deep Covers over the Cam Locks.

Questions? Please call 1-800-443-5117.
Customer Service available 8:30 - 5:00 Central Time, Monday - Friday

List of Hardware:

Part	Part

- 1.) Install 4 leveling glides.
- 2.) Use the screws to attach drawer pulls.
- 3.) To install under desk, remove the top box drawer (or top two box drawers) by locating the black tabs inside of the left & right drawer slides. Push down on one and push up on the other. This will release the drawer from the slides. Use 4 large bolts to connect to threaded holes on underside of desk. Once done, simply insert drawers back into the slides. They will snap in place.

Desk/Credenza Shell Assembly Instructions

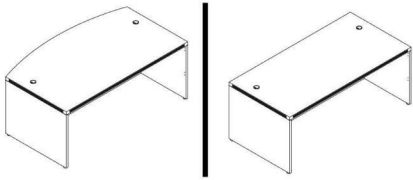

Applies to:

(BK/CH/MJ/ML/MWAL/WH) 2001/2002/2043/2089/3624/7124

List of Hardware:

Part	Part
	
Wood Dowel	Cap
	
Cam Pin	Leveling Glide
	
Cam Lock	Grommet

Tools Needed:
-Phillips Screwdriver
- A helper!

- 1.) Assemble on carpet or cardboard to protect parts during assembly. Assembly will require 2 people for safety.
- 2.) Locate left & right side panels. Screw in the leveling glides by hand. Then, insert wood dowels & cam pins. The wood dowels fit into the slightly larger holes, compared to the cam pin holes
- 3.) Locate front panel and insert all cam locks on the left & right sides. Then, align one of the side panels and connect the panel by inserting the cam pins into the cam locks and the dowels into the corresponding holes. (see diagram on next page). Twist the cam locks with a Phillips Screwdriver to secure.

Special Note:

Location & number of cam pin, cam lock and dowel holes may vary.

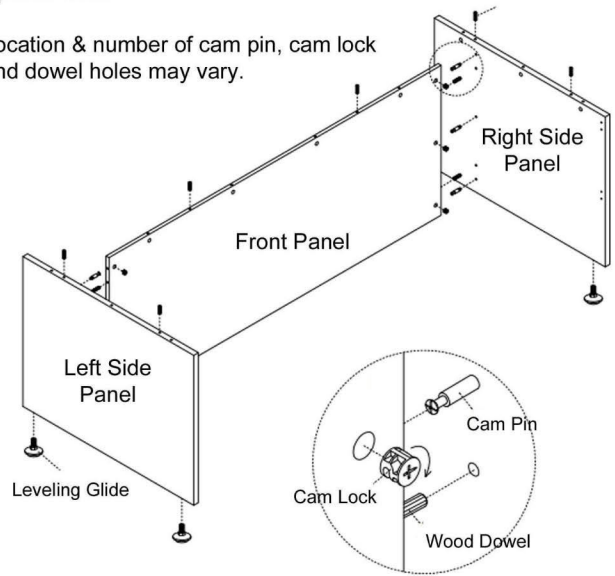

- 4.) Next, insert all cam pins, dowels and cam locks on the top edges of the side panels and front panels. Locate the desktop and with a helper, carefully set the desktop on top of the assembly shown above. Twist cam locks to secure the connection.
- 5.) Your last step is to insert the grommet(s) provided into the desktop. Cover the cam locks with the caps provided.

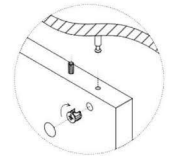
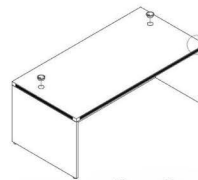

Questions? Please call 1-800-443-5117.

Customer Service available 8:30 - 5:00 Central Time, Monday - Friday