

Sintered Stone Table Assembly Instructions



Special Note: The sintered stone table tops you received have a laminate underside for mounting purposes. Use the wood screws provided and a power screwdriver to make your own holes and attach the top(s) to the disc table base(s).



M8*30 6PCS



M5*20 16PCS

**Questions? Call Customer Service at 1-800-443-5117 Mon-Fri,
8:30-5PM Central Time or email at
CustomerSvc@ModernOfficeFurniture.com**

**Assemble in the area you plan to use the table. Use cardboard
for protection if assembling on hard floors.**

Step 1) Assemble Table base using M8*30 Machine Bolts. Attach post to bottom plate using three bolts, then attach top bracket using the other 3 bolts.

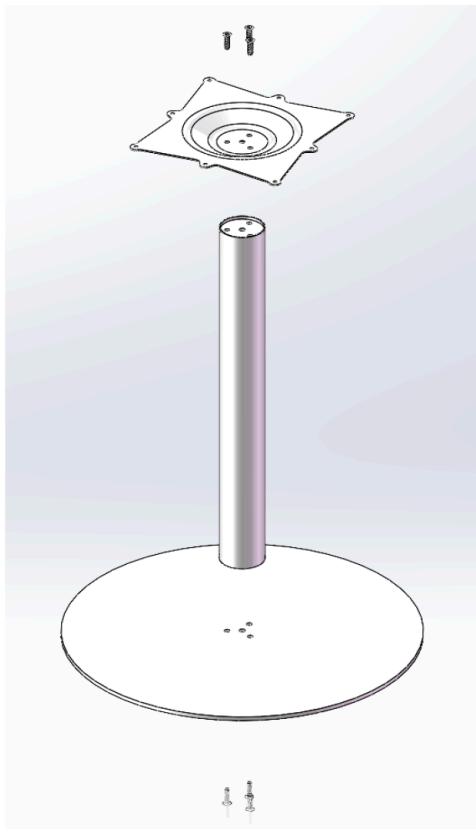

Step 2) With a helper, center the table base(s) under the table top. Space as evenly length-wise and depth-wise as possible. Using the M5*20 Self-Threading Wood Screws, drill into the board on the underside of the table top, using a power screwdriver.

