

White Laminate Panel / Cubicle Assembly Guide

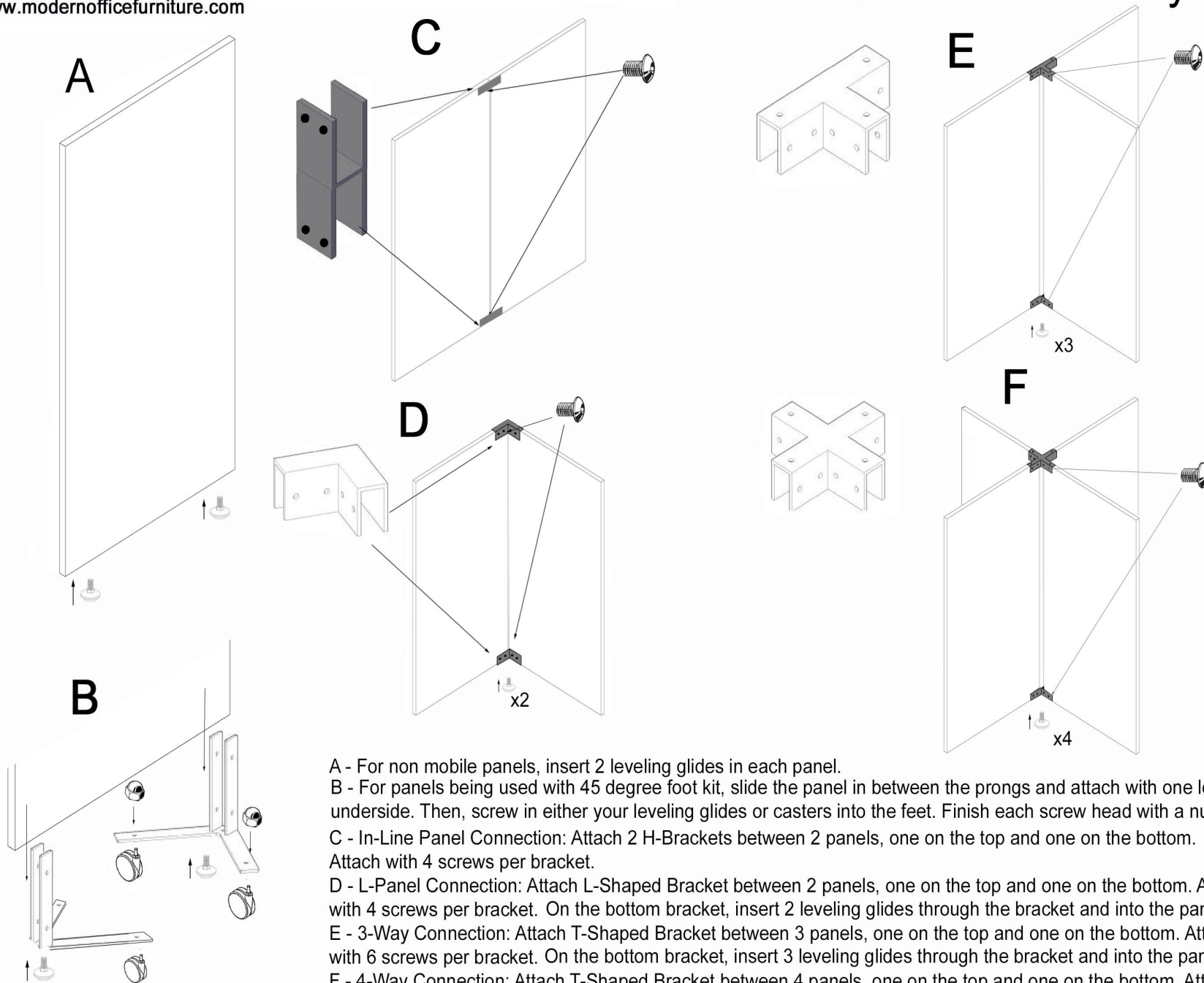

A - For non mobile panels, insert 2 leveling glides in each panel.

B - For panels being used with 45 degree foot kit, slide the panel in between the prongs and attach with one leveling glide on the underside. Then, screw in either your leveling glides or casters into the feet. Finish each screw head with a nut cap.

C - In-Line Panel Connection: Attach 2 H-Brackets between 2 panels, one on the top and one on the bottom. Attach with 4 screws per bracket.

D - L-Panel Connection: Attach L-Shaped Bracket between 2 panels, one on the top and one on the bottom. Attach with 4 screws per bracket. On the bottom bracket, insert 2 leveling glides through the bracket and into the panels.

E - 3-Way Connection: Attach T-Shaped Bracket between 3 panels, one on the top and one on the bottom. Attach with 6 screws per bracket. On the bottom bracket, insert 3 leveling glides through the bracket and into the panels.

F - 4-Way Connection: Attach T-Shaped Bracket between 4 panels, one on the top and one on the bottom. Attach with 8 screws per bracket. On the bottom bracket, insert 4 leveling glides through the bracket and into the panels.

Questions? Please call 1-800-443-5117.

Customer Service available 8:30 - 5:00 Central Time, Monday - Friday

White Laminate Cubicle Assembly Guide

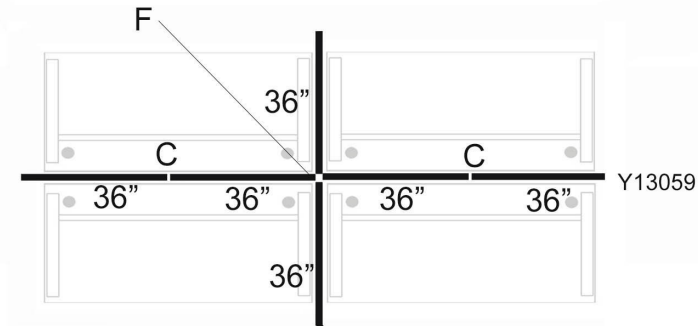
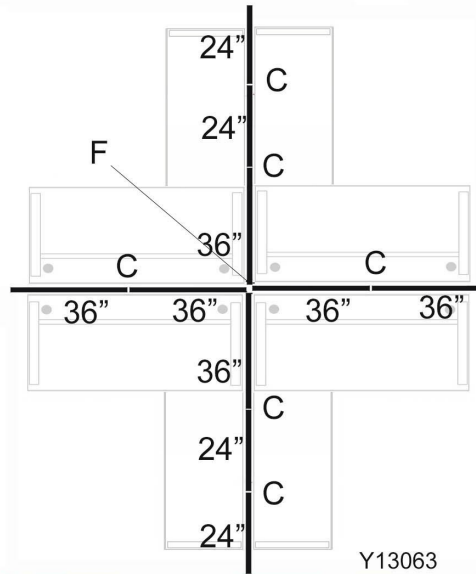
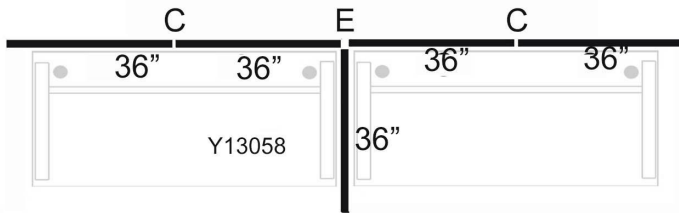
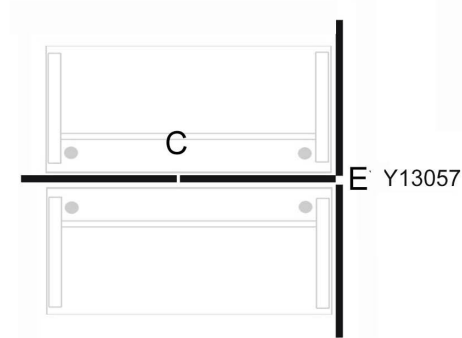
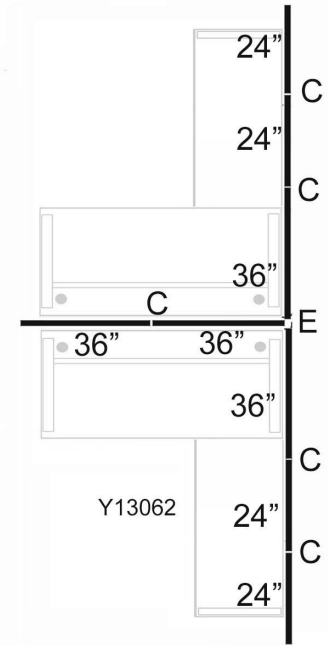
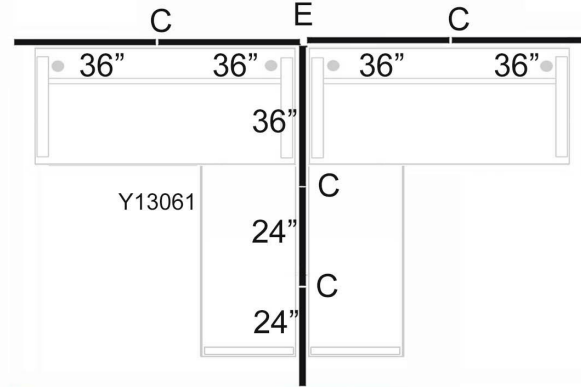
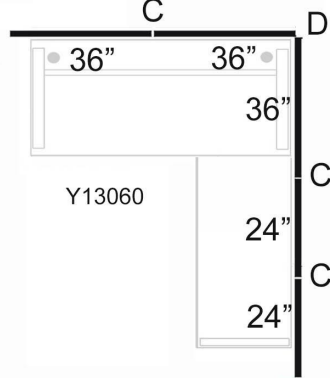
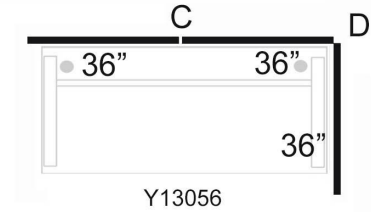

24" = 24"W Panel
30" = 30"W Panel
36" = 36"W Panel

C = In Line Bracket
D = L-Shaped Bracket
E = T-Shaped Bracket
F = X-Shaped Bracket

Questions? Please call 1-800-443-5117.
Customer Service available 8:30 - 5:00 Central Time, Monday - Friday

TrendSpaces Desk Series
Desk/Credenza Assembly Instructions
L-Desk Assembly Instructions
 (PLT2472, PLT3066, PLT3672 & PLT2448
 PLTLEGD2472, PLTLEGD30, PLTLEGD36 & PLTLEGD24)

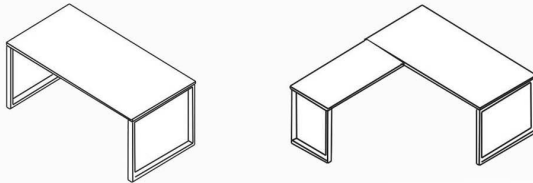

List of Hardware:

Part	Part
 Leveling Glide	 3/4" Bolt
 2-1/2" Bolt	 Bracket (for return desks only)
 Grommet	

Tools Needed:

- Allen Wrench included (to connect bolts)
- Power Screwdriver
- A Helper

Desk or Credenza:

- 1.) Assemble on carpet or cardboard to protect parts during assembly. Assembly will require 2 people for safety.
- 2.) Screw in leveling glides on all frames.
- 3.) Next, assemble metal desk frame by attaching the cross beam to the left & right side legs. The bolts for the cross beam are already in the legs. Just back out, place beam and screw back in. Use 16 of the 3/4" bolts total for this step, 8 for each side.
- 4.) Use a total of 4 of the 2" Bolts to attach the metal frame to the worksurface. Once connected, insert the grommets.

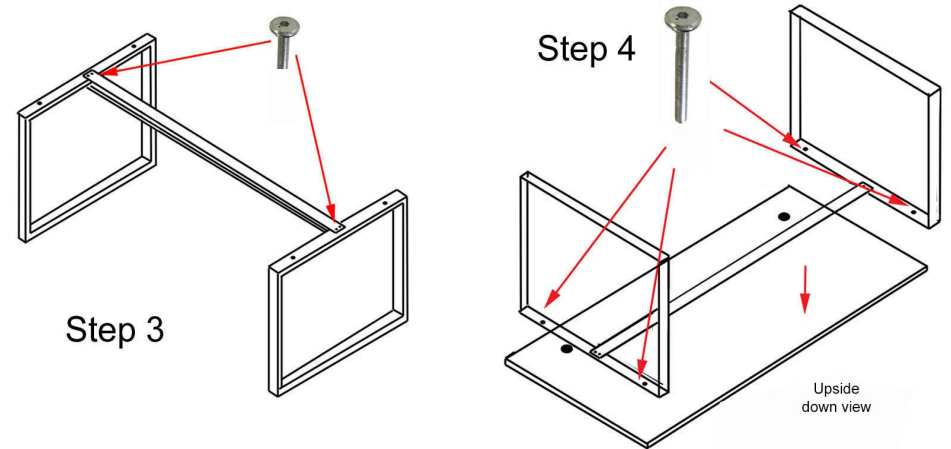

Return Desk:

- 5.) If you purchased an L-desk, attach the return desk end leg to the desktop with 2 more 2" Bolts, that are taped to the leg.
- 6.) The mounting bracket will already be installed on the return desktop. Use a total of 6 of the 3/4" Bolts to attach the bracket to the underside of the two worksurfaces.

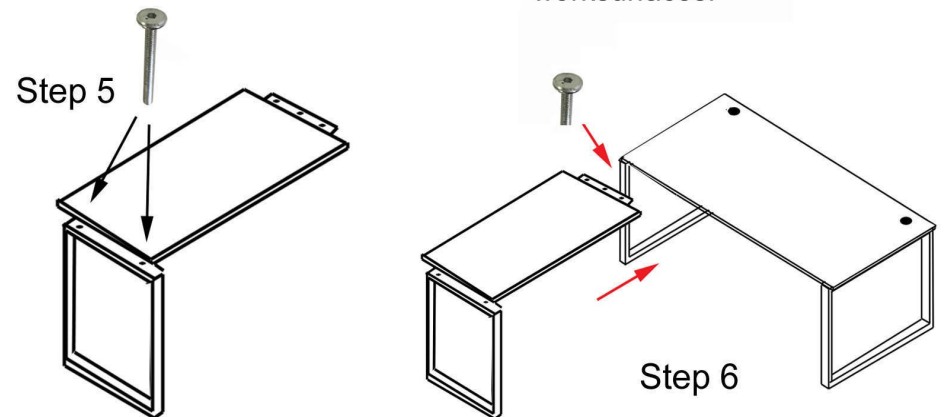

Questions? Please call 1-800-443-5117.

Customer Service available 8:30 - 5:00 Central Time, Monday - Friday