

Desk/Credenza Shell Assembly Instructions

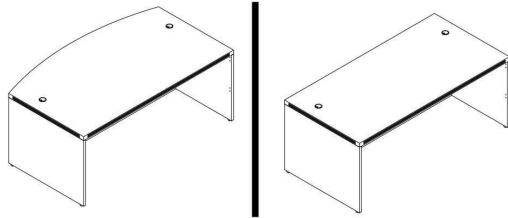

Applies to:

(BK/CH/MJ/ML/MWAL/WH) 2001/2002/2043/2089/3624/7124

List of Hardware:

Part	Part
 Wood Dowel	 Cap
 Cam Pin	 Leveling Glide
 Cam Lock	 Grommet

Tools Needed:

- Phillips Screwdriver
- A helper!

- 1.) Assemble on carpet or cardboard to protect parts during assembly. Assembly will require 2 people for safety.
- 2.) Locate left & right side panels. Screw in the leveling glides by hand. Then, insert wood dowels & cam pins. The wood dowels fit into the slightly larger holes, compared to the cam pin holes
- 3.) Locate front panel and insert all cam locks on the left & right sides. Then, align one of the side panels and connect the panel by inserting the cam pins into the cam locks and the dowels into the corresponding holes. (see diagram on next page). Twist the cam locks with a Phillips Screwdriver to secure.

Special Note:

Location & number of cam pin, cam lock and dowel holes may vary.

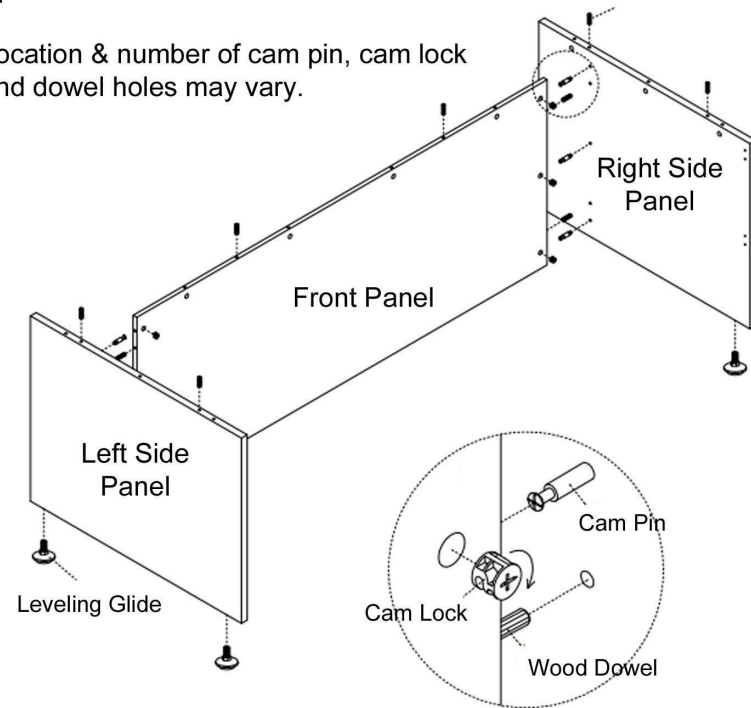

- 4.) Next, insert all cam pins, dowels and cam locks on the top edges of the side panels and front panels. Locate the desktop and with a helper, carefully set the desktop on top of the assembly shown above. Twist cam locks to secure the connection.

- 5.) Your last step is to insert the grommet(s) provided into the desktop. Cover the cam locks with the caps provided.

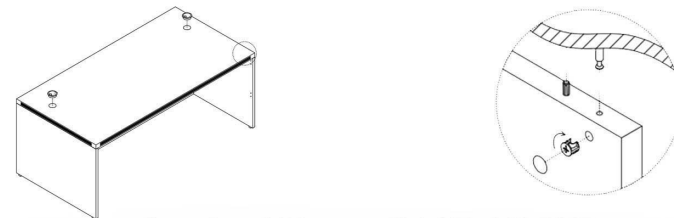

Questions? Please call 1-800-443-5117.





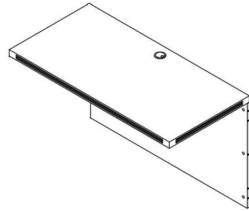





Customer Service available 8:30 - 5:00 Central Time, Monday - Friday

Reversible Bridge Assembly Instructions



Applies to:
BK/CH/FL/MJ/ML/WH2070

List of Hardware:

Part	Part	Part
 Wood Dowel	 Shallow Cover	 Worksurface Bracket
 Cam Pin	 Deep Cover	 Side Panel Brackets (2)
 Cam Lock	 Grommet	 M6 Screw
 Wood Screw		 Leveling Glide

Tools Needed:

- Phillips Screwdriver
- Power Screwdriver
- A Helper

1.) Assemble on carpet or cardboard to protect parts during assembly. Assembly will require 2 people for safety.

2.) Insert all wood dowels, cam pins and cam locks on the Desktop and Side Panel. Then, connect the two panels together by lining up the holes with the dowels & pins. Insert cam pins into holes that align with cam locks. Twist cam locks with a Phillips Screwdriver to secure the connection

3.) The next step is to attach the bridge between your desks. Locate the 2 Worksurface brackets (they may already be attached on the ends of the Desktop. If not, use the M6 Machine Screws to attach, centered over the edges of the Desktop like shown in drawing.)

Special Note:

Location & number of cam pin, cam lock and dowel holes may vary.

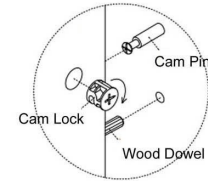

Step 5:
Offset Bracket

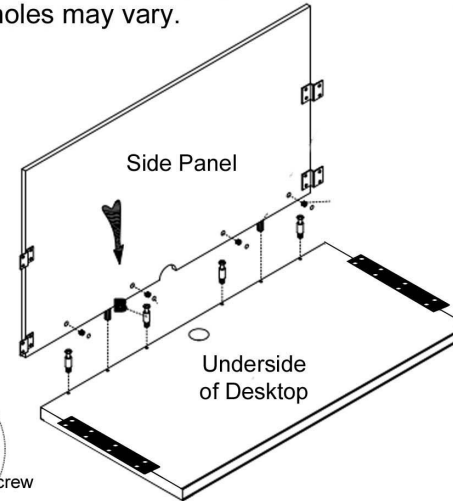
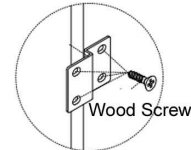

Left Hand Bridge

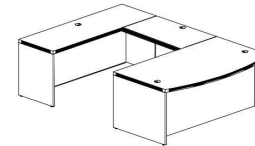

Right Hand Bridge

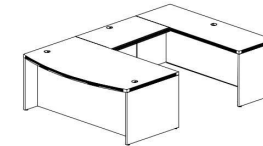

4.) Determine if the bridge will go on the left or right side of your desk. With a helper, have one person hold the bridge steady while the other person attaches the Worksurface Brackets to the undersides of the front desk & back credenza.

5.) Once installed & leveled, use the wood screws to install the offset side panel brackets. This will further secure the side panel, but is an optional step. A power screwdriver is helpful.

6.) Lastly, insert the grommet into the desktop and use the caps provided to cover the cam locks.

Questions? Please call 1-800-443-5117.



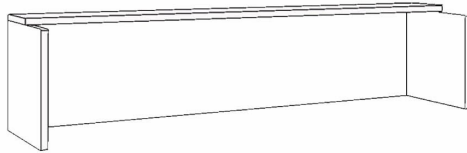

Customer Service available 8:30 - 5:00 Central Time, Monday - Friday

66"W & 71"W White Risers Assembly Instructions



Applies to:
WH2090, WH2095

List of Hardware:

Part	Part
	
Wood Dowel	Cover
	
Cam Pin	Cam Lock

Tools Needed:
-Phillips Screwdriver
- A helper!

- 1.) Assemble on carpet or cardboard to protect parts during assembly.
- 2.) First attach the Front Panel to one of the Side Panels using the cam lock/pin hardware provided. **DO NOT FULLY TIGHTEN THE CONNECTION!** Leave yourself wiggle room for the coming steps.
- 3.) Repeat process for the other Side Panel.
- 4.) Next, insert any/all wooden dowels, cam locks and pins into the Front Panel and Side Panels to connect the CounterTop. Set CounterTop on top of the assembly, over the pins & dowels.
- 5.) Once all parts are connected, tighten down all of the cam locks.

Special Note:

Location & number of cam pin, cam lock and dowel holes may vary.

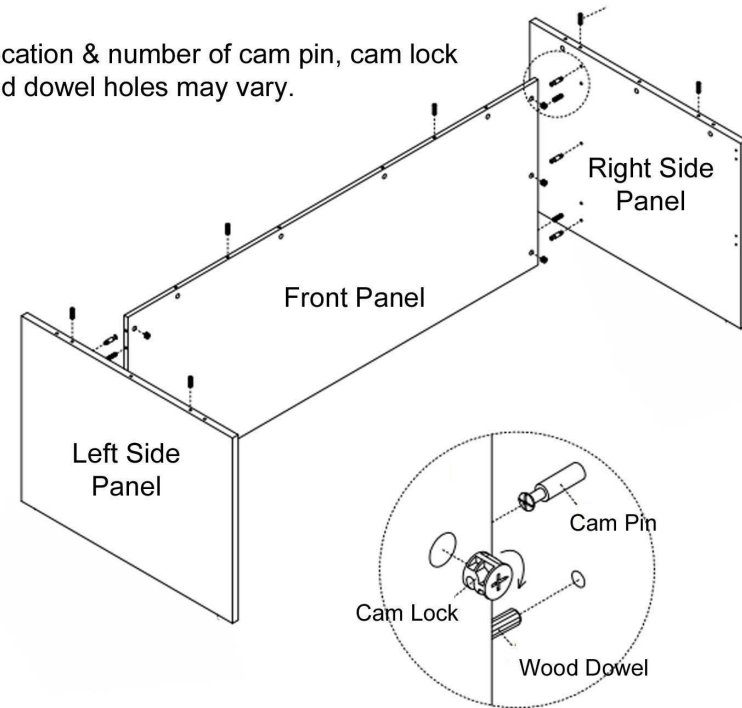

- 6.) With a helper, carefully lift the assembled Riser onto your desk. Remove the backing of the double sided tape at the bottom of the Side Panels and carefully place the riser down. After 24 hours, the tape will have a firm hold and the riser cannot be removed or budged.
- 7.) Cover any cam locks with white cam lock cover stickers.

Questions? Please call 1-800-443-5117.
Customer Service available 8:30 - 5:00 Central Time, Monday - Friday