

Industrial L-Desk Assembly Instructions

Questions: Call 1-800-443-5117, 8:30-5, Central Time, Mon-Fri

 <p>L-Bracket Qty 11</p>	 <p>Flat Bracket Qty 1</p>	 <p>Qty 3 M5x20 Self-Threading Wood Screw</p>	 <p>Qty 6 M6x120 Machine Bolt</p>	 <p>Qty 25 M6x16 Machine Bolt</p>	<p>Tools You Will Need:</p> <ul style="list-style-type: none"> -Screwdriver -Power Screwdriver -A Helper
---	---	---	--	--	---

Step 1

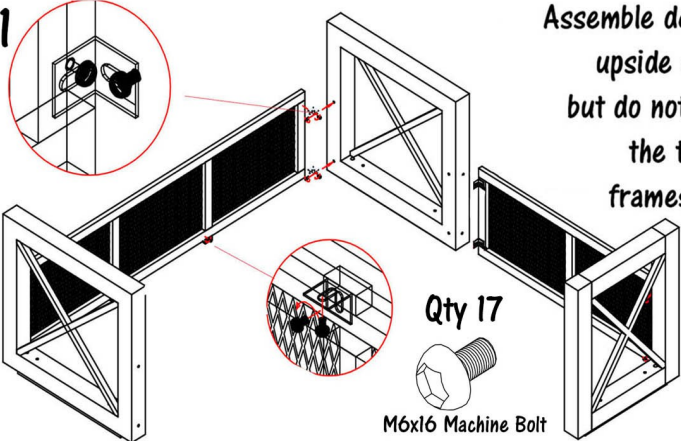

Assemble desk frames upside down, but do not connect the two frames yet!

Qty 17
M6x16 Machine Bolt

Step 1) Determine if you want a Left or Right Return. A Left Return is shown above. Assemble the main desk and return desk frames independently, using a screwdriver.

Step 2

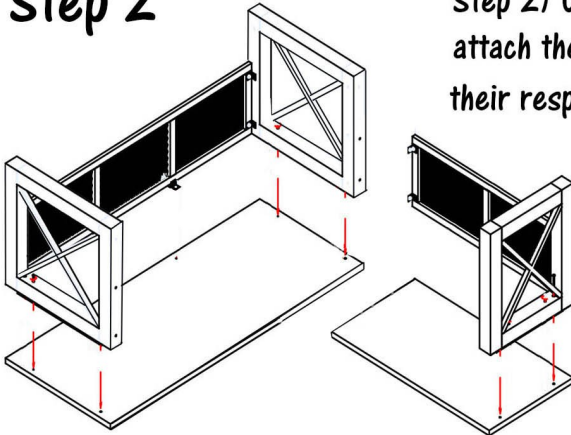

Step 2) Using the M6x120 machine bolts, attach the the worksurfaces to their respective desk frames.

Qty 6
M6x120
Machine Bolt

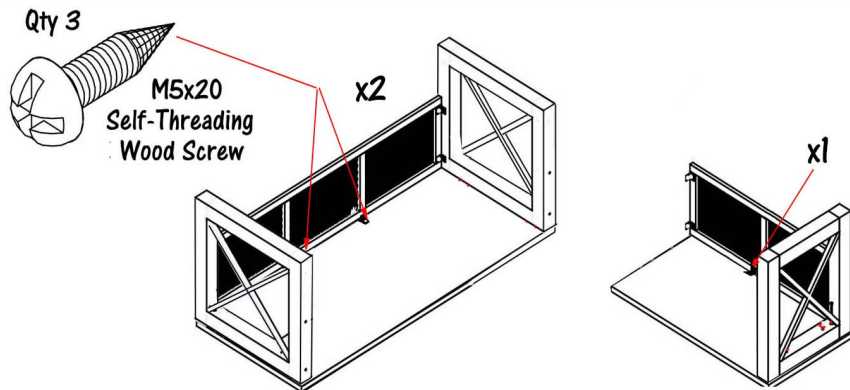

Qty 3
M5x20
Self-Threading
Wood Screw

x2

x1

Step 3). Using the M5x20 Self-Threading Wood Screws and a Power Screwdriver, attach the modesty panels to their respective worksurfaces. The screws are self-threading, so you will make your own holes.

Step 4

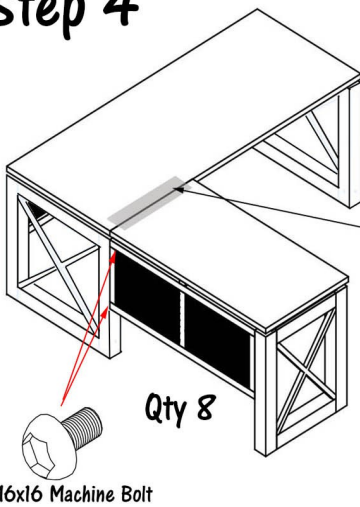

Step 4) With a helper, turn both desk sections over, right side up. Then, attach the return desk to the main desk using two M6x16 Bolts. Also, attach the Flat Bracket over the seam of the two desk sections using six M6x16 Bolts.

Flat Bracket will attach to the underside, over the seam of the two worksurfaces.

Qty 8
M6x16 Machine Bolt