

TrendSpaces U-Shaped Desk with Hutch Assembly Instructions

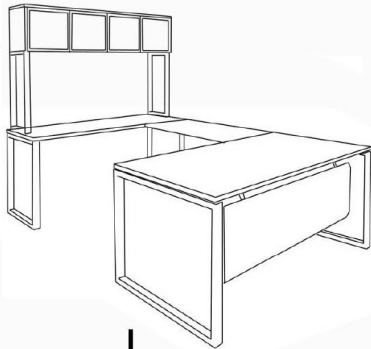

List of Hardware:

Part	Part
 Leveling Glide	 3/4" Bolt
 2" Bolt	
 Grommet	

Tools Needed:

- Allen Wrench included (to connect bolts)
- A Helper

To assemble front & back desk:

- 1.) Assemble on carpet or cardboard to protect parts during assembly. Assembly will require 2 people for safety.
- 2.) Screw in leveling glides on all frames.
- 3.) Next, assemble metal desk frame by attaching the cross beam to the left & right side legs. The bolts for the cross beam are already in the legs. Just back out, place beam and screw back in. Use 16 of the 3/4" bolts total for this step, 8 for each side.
- 4.) Use a total of 4 of the 2" Bolts to attach the metal frame to the worksurface. Once connected, insert the grommets.

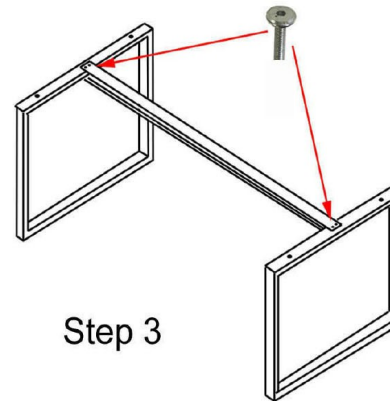

Step 3

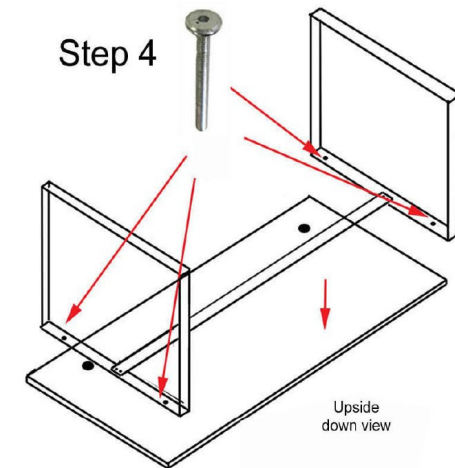

Step 4

Questions? Please call 1-800-443-5117.
Customer Service available 8:30 - 5:00 Central Time, Monday - Friday

Y11129 Steel Modesty Panel Assembly Instructions (MMP6016-SLV) (front desk)

Note: Holes are not predrilled on the underside of the worksurface due to the self-threading design of the pointed tip, coarse thread wood screws provided. The four wood screws will ensure a strong hold when screwed directly into the wood.

Positioning of the modesty panel is left to the personal preference of the user. It can either be placed flush to the front edge of the desk, or, set back several inches from the front edge.

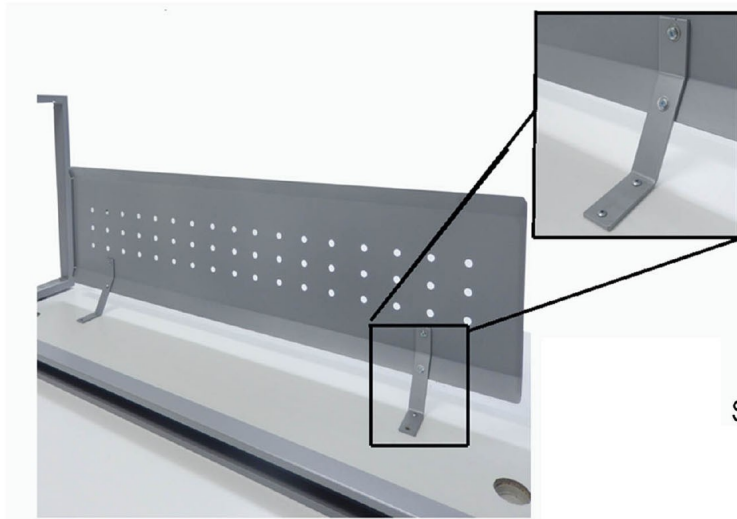

Step 1: Modesty Panel is easiest to attach when desk is upside down. Attach the two angled brackets to the modesty panel itself with the four bolts and washers provided. Screw silver caps on other side of panel once done.

Step 2: Next, measure your desktop and determine if you want your panel to overhang, be flush with, or be inset from the edge of the desktop. Line up modesty panel and mark holes where the angled bracket will be attached to the underside of the desk.

Step 3: Using a screwdriver or drill, attach the bracket by screwing the pointed wood screws into the underside of the desk, over the marks. Once done, with a helper turn the desk upright.

List of Hardware:

Part
 Wood Screw

Tools Needed:

- Screwdriver or power screwdriver
- A Helper.



Questions? Please call 1-800-443-5117.

Customer Service available 8:30 - 5:00 Central Time, Monday - Friday

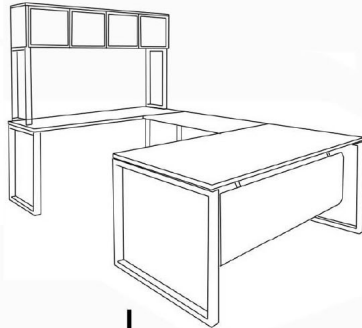
TrendSpaces U-Shaped Desk with Hutch Assembly Instructions



List of Hardware:

Part	Part
	
QTY 2	QTY 12

To Attach Reversible Bridge:

- 1.) Place your back desk 4' behind your front desk. Determine if you want a left or right return desk.
- 2.) Locate your kit marked "PLTBACKET SET".
- 3.) With a helper, have one person hold up the reversible bridge while the other installs the brackets. Center the brackets over the seams and install 6 machine screws through the large holes on the bracket into the pre-installed inserts on the underside of the desk top.

Tools Needed:

- Allen Wrench included (to connect bolts)
- Power Screwdriver
- A Helper

Step 3:

Overhead view of U-Desk shown with Left Hand Bridge with placement of brackets

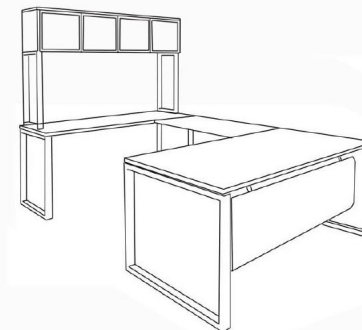
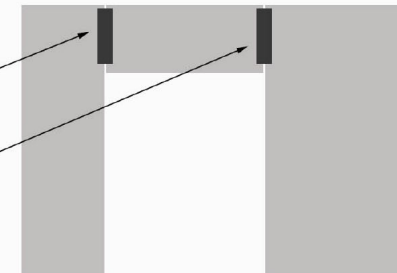

Left Hand Bridge

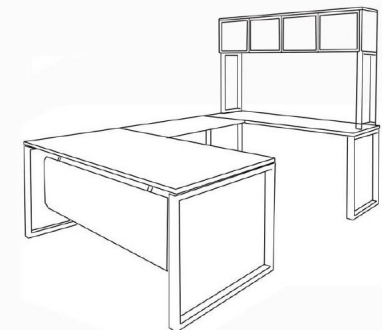





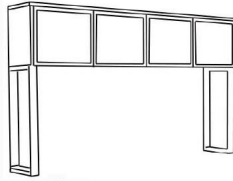

Right Hand Bridge

Questions? Please call 1-800-443-5117.
Customer Service available 8:30 - 5:00 Central Time, Monday - Friday

TrendSpaces Desk Series
Hutch Assembly Instructions
for Y11873 U-Desk with Hutch,
Y11133 Wall Mounted Hutch &
Y11134 Desk Mounted Hutch
(1044WS & HUTCHLEGS-SLV)

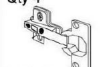

List of Hardware:

Part	Part	Part
 Wood Dowel	 Cam Lock Cap	Qty 4  Outside Door Hinge
 Cam Pin	 Machine Screw	Qty 4  Inside Door Hinge
 Cam Lock		Qty 8  Hinge Plate

Tools Needed:

- Allen Wrench included (to connect bolts)
- Power Screwdriver
- A Helper

1.) Identify the parts of the hutch using Fig 1. Assemble on cardboard or carpet to protect parts during assembly.

2.) Assemble upside down like shown in Fig 1. Attach panels using wood dowels, cam locks and cam pins in the order shown below. **LEAVE CAM LOCKS LOOSE DURING ASSEMBLY. FULLY TIGHTEN WHEN ALL PARTS CONNECTED:**

- A - Attach Left Side Panel to Top Surface.
- B - Attach Middle Support to Top Surface.
- C - Attach Right Side Panel to Top Surface.
- D - Attach Back Panel to Top Surface, Side Panels and Middle Support.
- E - Attach Bottom Shelf.

3.) You will notice the Back Panel has a pre-installed brace. This is for if you plan to mount your hutch on your wall. There is wood brace included with your hutch that should be installed onto your wall, into your wall studs, with the angled side facing "up".

The preinstalled brace will fit into the wall brace.

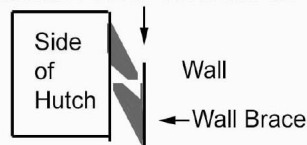
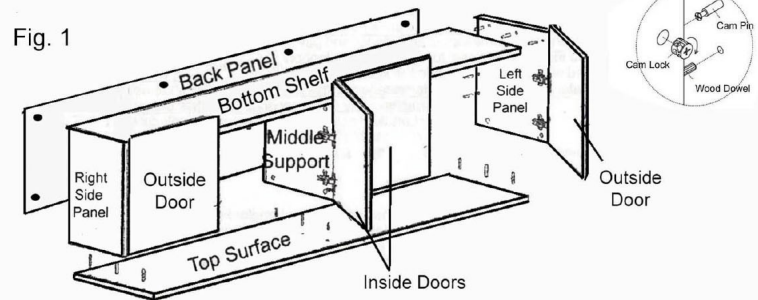

Fig. 1



Special note: wall mounting hardware is not included. Due to the variety in wall and stud material, there is no universal screw that will work with all wall/studs. Customers to supply own hardware to mount brace.

If you plan to attach the hutch to the desk, go to Step 4. If you plan to mount to the wall, go to Step 6.

4.) Attach hutch legs to the bottom of the hutch using the machine screws, 4 per side.

5.) Next, attach your hutch to its final destination, whether on a credenza for a U-Desk or on top of lateral files or open storage units. Use the machine bolts to attach the hutch legs to the pre-drilled inserts on top of the credenza worksurface or lateral files, etc.

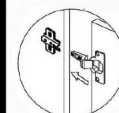

Step 8



Step 9

6.) Once the hutch is positioned and will no longer need to be moved, it is time to attach the doors. Connect all 8 hinge plates to the inside side panels using the screws provided. **LEAVE HINGE PLATES LOOSE!**

7.) Next, locate all of the hinges sort out the 'inside door' hinges from the 'outside door' hinges. They look slightly different. See Fig 2. below. The doors are all made the same.

8.) Attach 2 hinges per door. Use the hinges with the 'bump' on the outside left & right doors and the flat hinges on the inside left & right doors. Once hinges are attached, slide the doors/hinges over the hinge plates, fitting the screw head of the hinge plate into the slot of the hinge. Once fitted, tighten the set screw.

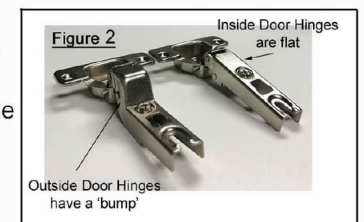

9.) Align the hutch doors by using your screwdriver to adjust the set screw to adjust the depth and screws on the hinge plates to move the door up/down. Once aligned,

Video on Hinge Door Adjustment available at link:
<http://www.modernofficefurniture.com/office-furniture-assembly-instructions.html>

"How to Adjust Hinges on 4-Door Hutch"

Questions? Please call 1-800-443-5117.
Customer Service available 8:30 - 5:00 CT

Monday - Friday