

Y12591 - Y12596 & Y12734 - Y12736 Curved Reception Desk Assembly Instructions



List of Hardware:

Part	Part
 Wood Dowel	 Cap
 Cam Pin	 Leveling Glide
 Cam Lock	 Grommet
 Posts for Glass	 Bracket & Screw Set

Tools Needed:

- Phillips Screwdriver
- A helper!

1.) Assemble on carpet or cardboard to protect parts during assembly. Assemble in area of use. Requires 2 people for safety during assembly.

2.) Lay out Curved Front Panel, Side Panels and Desktop and insert all cam locks, cam pins and wood dowels.

3.) Next, attach the Desktop to the Curved Front Panel and Side Panel. Choose from two desktop height settings: 29"H for seated height and 35" for standing height.

4.) Then, attach one of the Side Panels to the Curved Front Panel, inserting the cam pins into the holes for the cam locks. Use your screwdriver to twist the cam locks to tighten.

5.) Attach the remaining Side Panel to the Curved Front Panel and Desktop. Then, use the wood screws to attach the L-brackets under desktop as shown on next page.

View from underside to show hardware connections

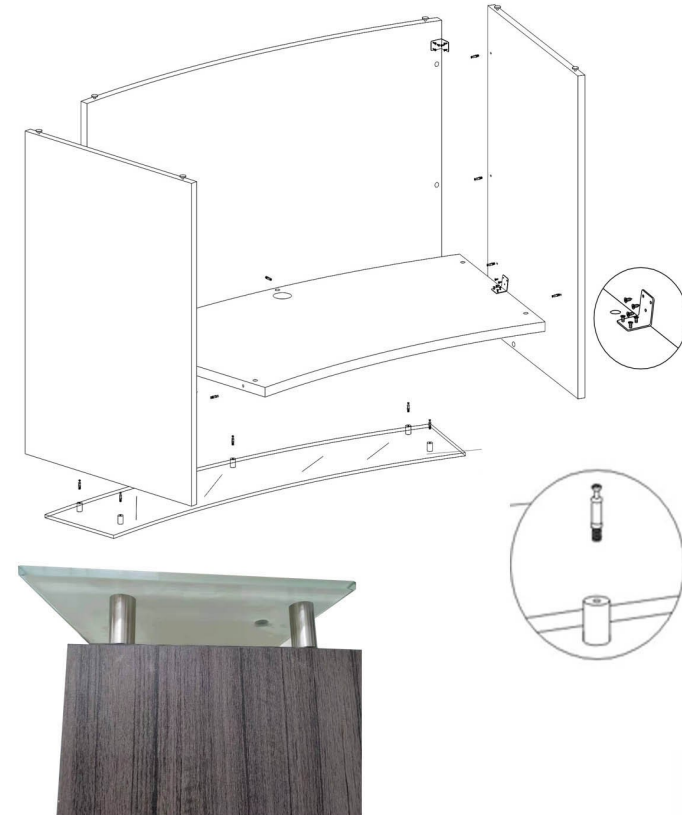

6.) Locate all posts for the glass. Screw the posts onto the pucks on the underside of the glass. Then, insert cam pins into the posts.

7.) Next, with a helper, turn the glass right side up and carefully place on top of the desk, lining up the cam posts to insert into the holes on the edges of the desk. Then, turn the cam locks to secure the cam pins in place.

8.) Your last step is to add the grommet to the desktop and cover the cam locks with the caps/stickers provided. If multiple units purchased, simply butt up the desks side by side. No bracketing needed.





Questions? Please call 1-800-443-5117.

Customer Service available 8:30 - 5:00 Central Time, Monday - Friday

Box/Box/File Desk Pedestal Extender Assembly Instructions



List of Hardware:

Part	Part
 Cam Lock & Pin Set	 Wood Dowel
 Adhesive Caps	 Bolt

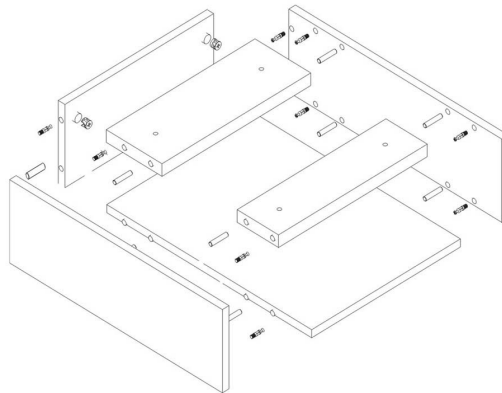

Step 1: Flip bottom panel hole side face down.



Assemble one side panel first, not both

This is just to illustrate how sides attach

Finished edges facing out on this side



Step 2: Attach one side panel only.

Step 3: Attach Back Panel.

Step 4: Attach both Top Braces, then attach the other side panel.



Attach top braces on one side, then attach other side panel

5.) Add adhesives over cam lock holes.

6.) Attach this piece to the top of your file pedestal using the 4 bolts included



Questions? Please call 1-800-443-5117.
Customer Service available 8:30 - 5:00 Central Time, Monday - Friday

Box/Box/File Desk Pedestal Assembly Instructions

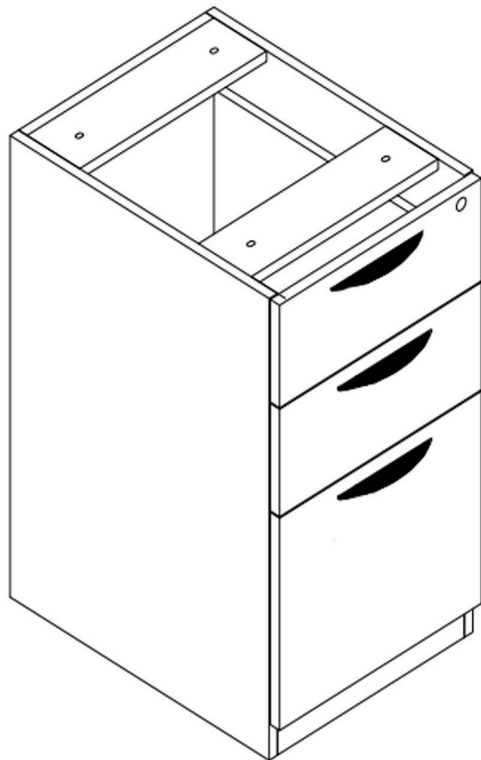
Applies towards:
 BK/CH/FL/MJ/ML/WH2066

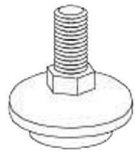

List of Hardware:

Part	Part
 4 Large Bolts	 3 Drawer Pulls with screws
 1 set of keys	 4 Leveling Glides

- 1.) Install 4 leveling glides.
- 2.) Use the screws to attach drawer pulls.
- 3.) To install under desk, remove the top box drawer (or top two box drawers) by locating the black tabs inside of the left & right drawer slides. Push down on one and push up on the other. This will release the drawer from the slides. Use 4 large bolts to connect to threaded holes on underside of desk. Once done, simply insert drawers back into the slides. They will snap in place.