



Toll Free: 1-800-443-5117
www.modernofficefurniture.com

Office Panel Installation Instructions

Questions? Call Customer Service at 1-800-443-5117, 8:30-5 Central Time, Mon-Fri

Tools Needed: Phillips Screwdriver, Rubber Mallet, WD-40 and Clean Hands! Hardware Included: Each Panel includes Mounting Brackets. End Strips provided for end of panel runs.

Important Assembly Tips:

- * If needed, use of a lubricant such as WD-40 in the side track may ease the process of removing and replacing mounting brackets, as well as sliding in end strips if an overly tight fit. Be careful not to overspray lubricant onto the panel.
- * Mounting brackets should only be very loosely attached. The pointed Phillips set screw attached to the brackets is merely for bracket positioning. Leaving the brackets as loose as possible will allow the connections to fit together properly.
- * When installing an arrangement of panels, installation will be easier if the brackets of the first panel have the opening facing upward (see diagram below). This way, the next panel bracket drops into the receiving bracket, rather than having to lift the first panel off the floor for the connection.

Assembly Video

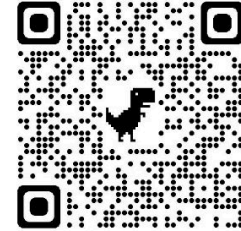

Step 1) Screw in two leveling glides into the base of each panel.

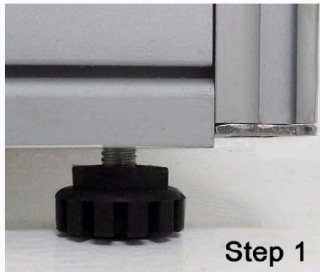

Step 1

Step 2) Insert Clips into tracks. On first panel, arrange the Clips into the "UP" position in the track. (see drawing on right.) On next connecting panel, arrange the Clips in the "DOWN" position. Repeat on each panel as needed.

48"H Panels & Posts: 3 Clips in each track
67"H Panels & Posts: 3 Clips in each track
84"H Panels & Posts: 5 Clips in each track

Step 2

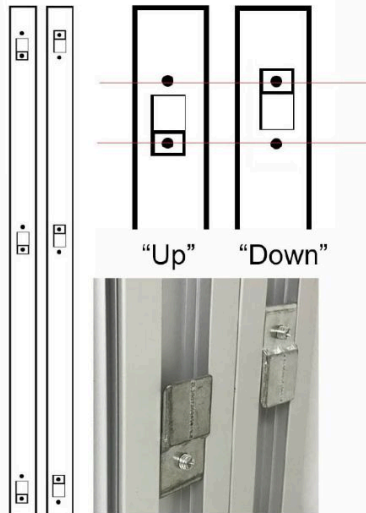

Step 3) Slide your second panel into your first panel by slightly tipping the second panel and dropping the brackets down into the first panel. Brackets will fit together. Repeat Steps 1 & 2 as needed.

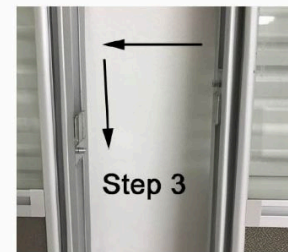

Step 3

Step 4) Connector Posts will need 3 mounting brackets per side/connection and attach in same method as panels.

See video above!!!!

Step 5) Use the plastic end strips at the end of each panel run for a finished appearance. Do not add any mounting brackets in the rails when using the end strips.

Step 6) Cable troughs can be opened by inserting a straight blade screwdriver into the side or top edge to pop the door open.

TrendSpaces U-Shaped Desk Assembly Instructions

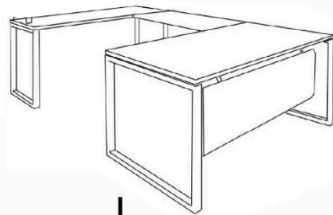

List of Hardware:

Part	Part
 Leveling Glide	 3/4" Bolt
 2" Bolt	
 Grommet	

Tools Needed:

- Allen Wrench included (to connect bolts)
- A Helper

To assemble front & back desk:

- 1.) Assemble on carpet or cardboard to protect parts during assembly. Assembly will require 2 people for safety.
- 2.) Screw in leveling glides on all frames.
- 3.) Next, assemble metal desk frame by attaching the cross beam to the left & right side legs. The bolts for the cross beam are already in the legs. Just back out, place beam and screw back in. Use 16 of the 3/4" bolts total for this step, 8 for each side.
- 4.) Use a total of 4 of the 2" Bolts to attach the metal frame to the worksurface. Once connected, insert the grommets.

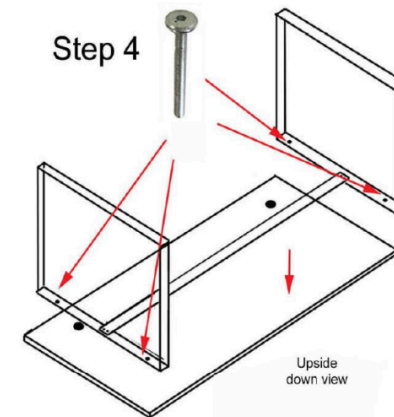
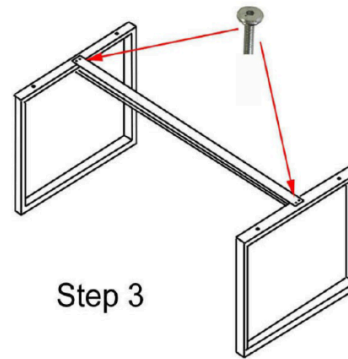

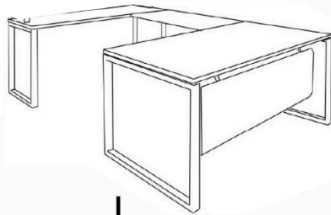

Questions? Please call 1-800-443-5117.
Customer Service available 8:30 - 5:00 Central Time, Monday - Friday

TrendSpaces U-Shaped Desk Assembly Instructions



List of Hardware:

Part	Part
	
QTY 2	QTY 12

To Attach Reversible Bridge:

- 1.) Place your back desk 4' behind your front desk. Determine if you want a left or right return desk.
- 2.) Locate your kit marked "PLTBACKET SET".
- 3.) With a helper, have one person hold up the reversible bridge while the other installs the brackets. Center the brackets over the seams and install 6 machine screws through the large holes on the bracket into the pre-installed inserts on the underside of the desk top.

Tools Needed:

- Allen Wrench included (to connect bolts)
- Power Screwdriver
- A Helper

Step 3:

Overhead view of U-Desk shown with Left Hand Bridge with placement of brackets

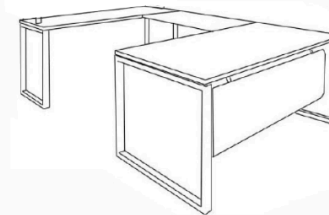
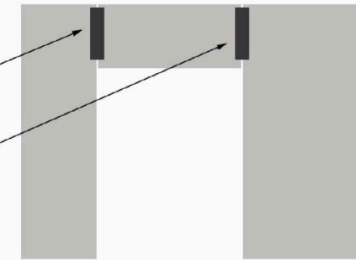

Left Hand Bridge

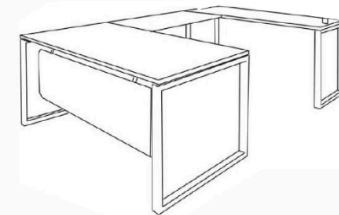

Right Hand Bridge

Questions? Please call 1-800-443-5117.

Customer Service available 8:30 - 5:00 Central Time, Monday - Friday

MODELS : 415VAF/415VAV GUEST / RECEPTION CHAIR WITH OPTIONAL CASTERS OR GLIDES

Parts Listing

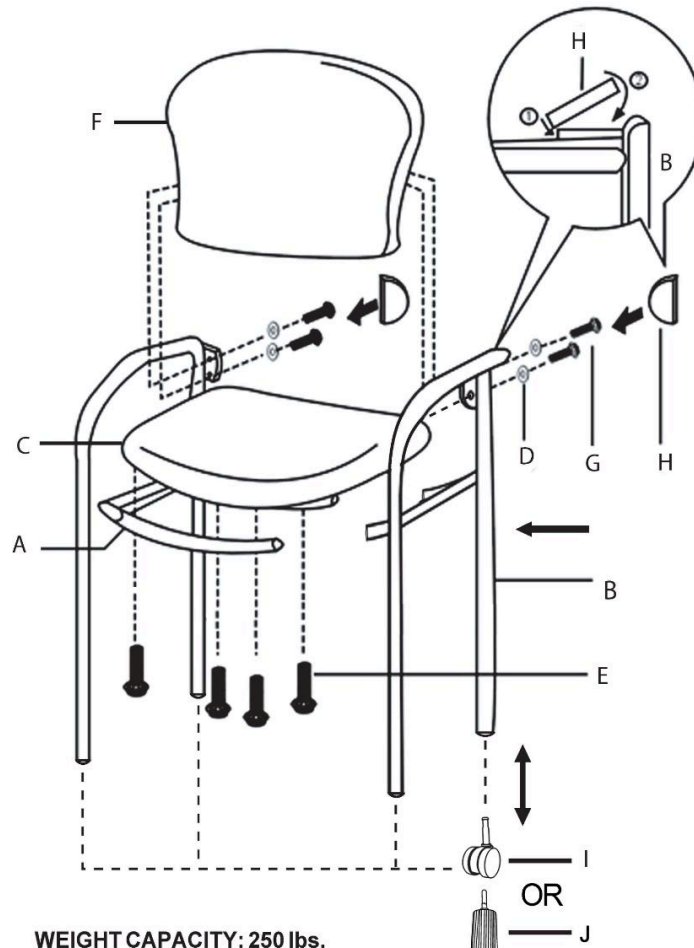
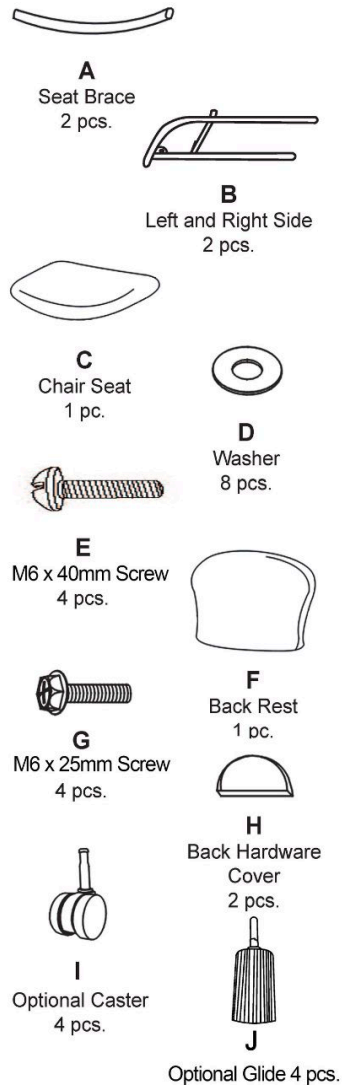

WEIGHT CAPACITY: 250 lbs.

Assembly Notes:

During assembly, hand tighten screws only. When all screws are in place, you may then tighten all screws completely.

CAUTION:

1. Do not use this chair as a step ladder.
2. Check for loose screws and tighten them every 6 months.

Assembly Instructions



Tools needed: Phillips Head Screwdriver
Please read all instructions before assembly.

Step 1: Attach Seat Braces (A) to Left and Right Sides (B), making sure that the pre-drilled holes in braces align with the holes in arms.

Step 2: Attach the Chair Seat (C) to the frame and insert four Screws (E) through the Seat Brace (A) and into the Chair Seat.

NOTE: Hand tighten screws only.

Step 3: Attach Back Rest (F) to the frame by placing four Washers (D) onto four Screws (G), and inserting them into the frame and into the Back Rest.

NOTE: Hand tighten screws only.

Step 4: Proceed to tighten all screws on Chair Seat and Back Rest with screwdriver.

Step 5: Place Back Hardware Cover (H) over the Back Rest Screws (G). Slide cover over frame and snap into place.

For installation of Model 415 ONLY!

Optional casters & glides Installation:

Step 6a: Lay chair down on level, non-abrasive surface and insert optional casters (I) or glides (J), into the fittings in the legs, making sure casters or glides are securely inserted into the legs.



Questions? Call Customer Service at 1-800-443-5117
Monday - Friday 8:30 AM to 5:00 PM Central Time
www.modernofficefurniture.com



Y11128 - Steel Box/Box/File



1.) Install 5 casters by hand. Casters snap into place.

2.) Insert keys.

PARTS LIST

Part	Part
	
	Keys

Y13362 - Mesh Chair Assembly Instructions

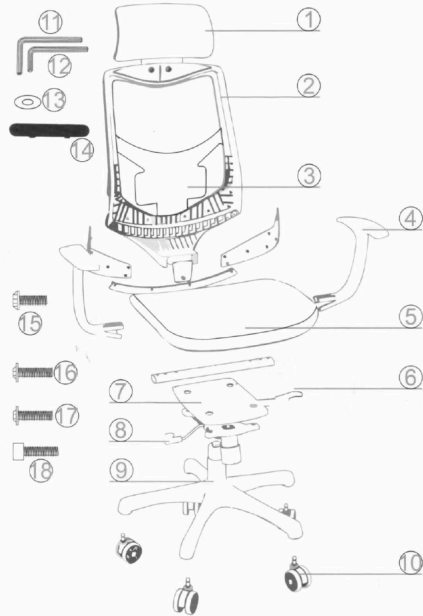

PARTS LIST

1. Headrest
2. Back cushion
3. Lumbar support
4. Armrest
5. Seat cushion
6. Back cushion adjust handle
7. Seat plate
8. Height adjust handle
9. Star base
10. Caster (5pcs)
11. M5 Allen key
12. M4 Allen key
13. Screw gasket M6x0.62inch(10PCS)
14. Back screw lid
15. Screw bolt M8x1.37inch(3PCS)
16. Screw bolt M6x1.18inch(4PCS)
17. Screw bolt M6x1.77inch(6PCS)
18. Screw bolt M6x0.78inch(2PCS)

SPECIFICATIONS

Chair weight: 31.3 lbs
 Load capacity: 275 lbs
 Size: 22.8x24.4x50.5 inches
 Product material: PA, PU, glass fiber, Aluminium alloy

PACKAGE INCLUDES

1x office chair (divided parts)
 2x wrench
 15x screw sets

INSTALLATION

1. Install the armrest on seat. Make sure to install at the right direction. For the seat cushion, the broad edge is the front, and the narrow edge is the back. The armrest with an "L" on the bottom is for the left side and "R" for the right side of the seat. The screw bolt should be the M6x1.77inch(6pcs) with a gasket(6pcs).

2. Install the seat plate with screw holes on the back of the seat cushion. Use the screw bolt M6x1.18inch(4pcs) with a gasket(4pcs).

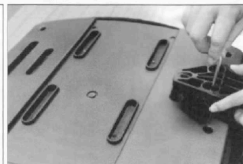
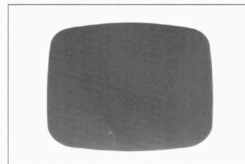

3. Insert the backrest bottom into the slot of the seat plate, use the screw bolt M8x1.37inch(3pcs) to fix.

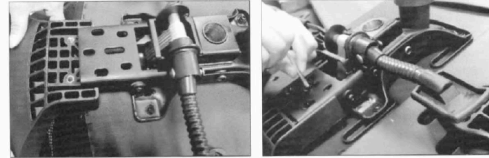

4. Insert the 5 casters into the alloy base, insert the gas lift into the hole on top of the alloy base, insert the top of the gas lift into the hole on the seat plate.

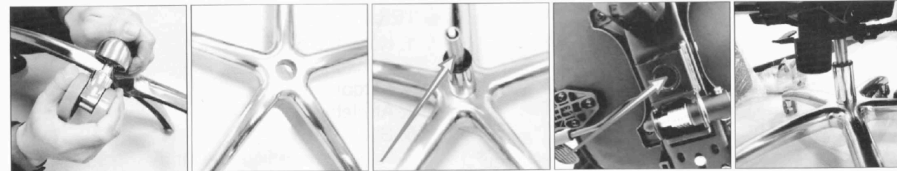

5. Use the screw bolt M6x0.78inch(2pcs) to fix the headrest onto the backrest then insert the screw slot cover.

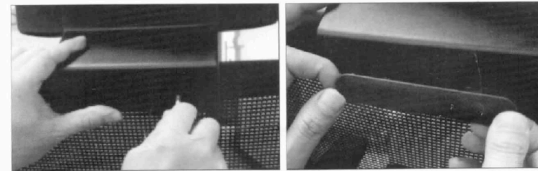

OPERATION INSTRUCTION

1. Press the button to adjust the height of armrest, loose the button to fix the position



2. Hold the armrest you can move it to front/back/left/right.



3. Lift the left button to adjust the angle of backrest and release to lock.

4. Lift the right button to adjust the height of chair and release to lock.

5. Lift and push to adjust the lumbar support.

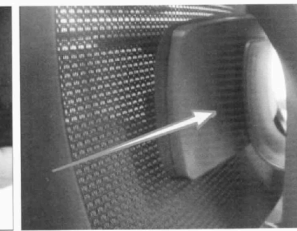

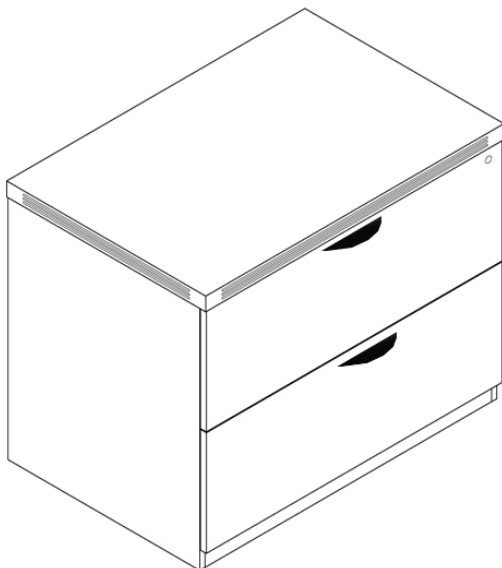

2-Drawer/4-Drawer Lateral File

MJ/FL/ML/WH2012
MJ/FL/ML/WH2012A

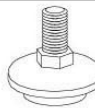

PARTS LIST

Part	Part
 Screw	 Drawer Pull
 Keys	 Leveling Glide

- 1) Install 4 leveling glides and level the file
- 2.) Install drawer pulls with screws provided.