

Y13558 / Y13559 Twin Saddle Stool Assembly Instructions

Parts Listing

- (1) Seat top
- (2) Mechanism (Posture & Pneumatic height)
- (3) Gas cylinder
- (4) Aluminum base
- (5) Caster x 5 pcs
- (6) M8 x 14 mm screw x 4 pcs

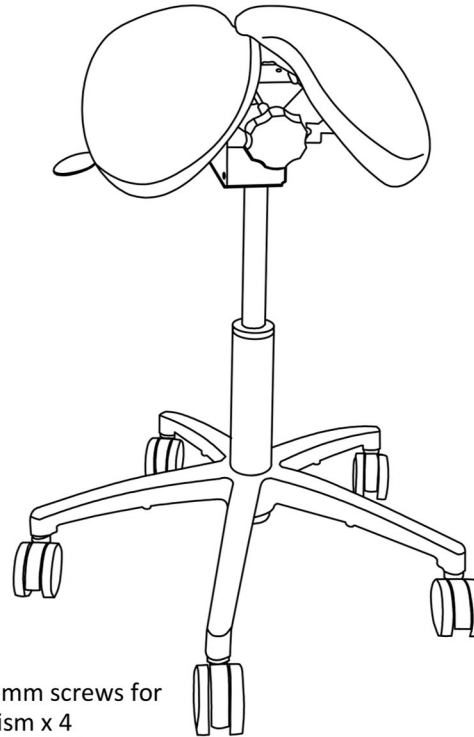
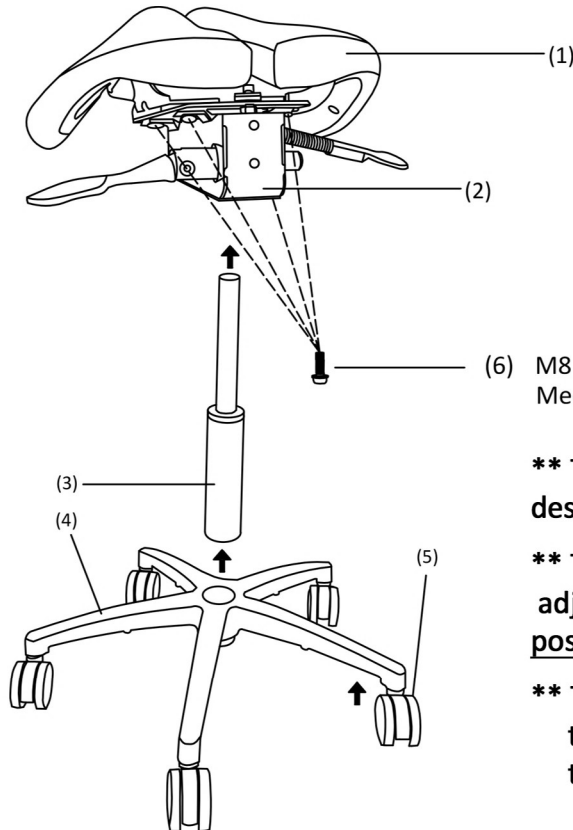

Please Read Instruction Before Assembly

**Tools needed : Phillips Head Screwdriver

- Step 1 : Insert the 5 casters (5) into the outer holes on the base (4)
- Step 2 : Insert the bottom end of the Gas cylinder (3) into the center hole of the base
- Step 3 : Connect the mechanism (2) with Seat top (1) by using 4 pcs M8 x 14 mm screws (6) and tightening it up.
- Step 4 : Place the Seat top (1) with mechanism (2) on top of the Gas cylinder (3) and make sure the top of Gas cylinder has been properly fitted into the hole of Seat mechanism.

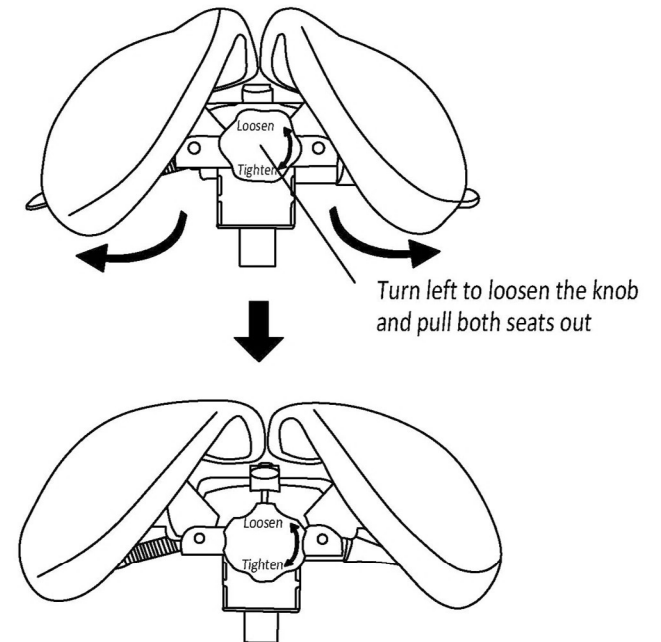

**** To adjust Seat height, lift right handle up or down to desired position.**

**** To adjust Seat posture, pull up the left handle to adjust posture, then push it down to set desired posture.**

**** To adjust Seat width, turn left to loosen pivotal knob, then pull both seats out simultaneously ; turn right to tighten and fix seat width.**

Caution: Do not use this chair as a step ladder
Check for loose screws and tighten them every month.

Questions? Call Customer Service at 1-800-443-5117
Monday - Friday 8:30 AM to 5:00 PM Central Time