

Y13561- Saddle Stool Assembly Instructions

Parts Listing

- (1) Seat top
- (2) Round ring mechanism
- (3) Gas cylinder
- (4) Steel base
- (5) Casters x 5 pcs
- (6) M6 x 30 mm screw 4 pcs & M6 washers 4 pcs

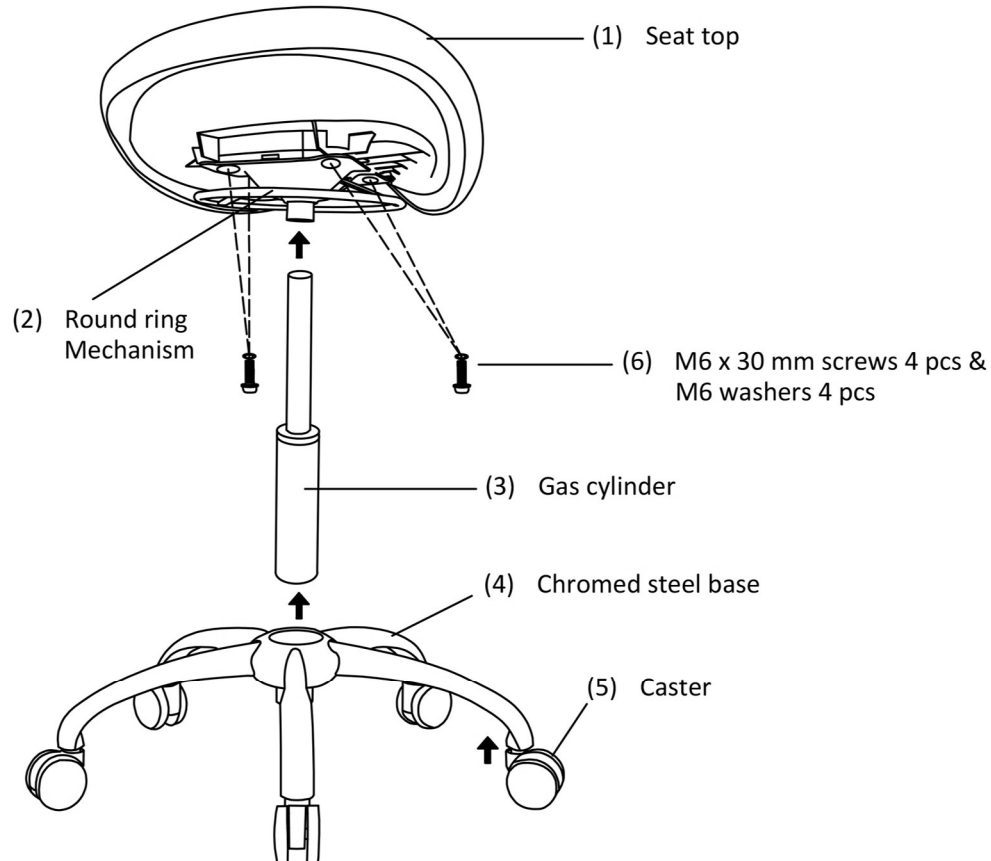

Please Read Instruction Before Assembly

**Tools needed : Phillips Head Screwdriver

- Step 1 : Insert the 5 casters (5) into the outer holes on the base (4).
- Step 2 : Insert the bottom end of the Gas cylinder (3) into the center hole of the base
- Step 3 : Connect Round ring Mechanism (2) with Seat top (1) by using 4 pcs M6 x 30 mm screws & 4 pcs M6 washer (6) and tightening them up.
- Step 4 : Place the Seat top (1) with mechanism (2) on top of the Gas cylinder (3) and make sure the top of Gas cylinder has been properly fitted into the hole of Seat mechanism

* To adjust seat height, lift round ring up or down to desired position.

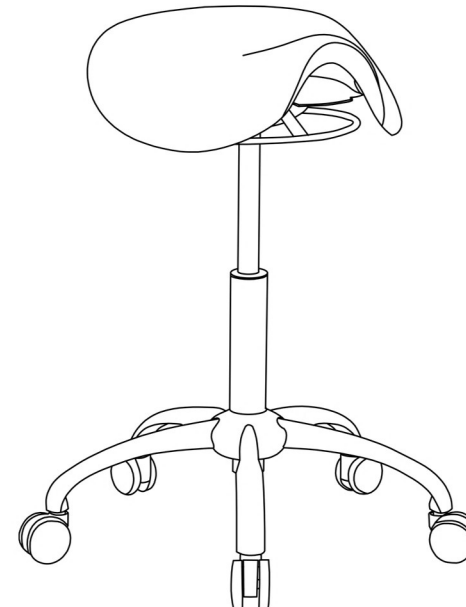

**Caution: Do not use this chair as a step ladder
Check for loose screws and tighten them every month.**

Questions? Call Customer Service at 1-800-443-5117
Monday - Friday 8:30 AM to 5:00 PM Central Time