

Industrial L-Desk Assembly Instructions

Questions: Call 1-800-443-5117, 8:30-5, Central Time, Mon-Fri

 <p>L-Bracket Qty 11</p>	 <p>Flat Bracket Qty 1</p>	 <p>Qty 3 M5x20 Self-Threading Wood Screw</p>	 <p>Qty 6 M6x120 Machine Bolt</p>	 <p>Qty 25 M6x16 Machine Bolt</p>	<p>Tools You Will Need:</p> <ul style="list-style-type: none"> -Screwdriver -Power Screwdriver -A Helper
--	--	--	---	---	--

Step 1

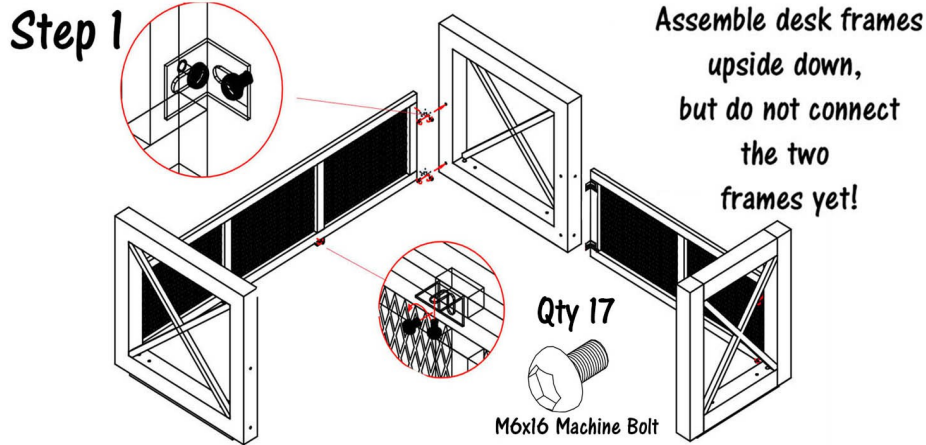

Assemble desk frames upside down, but do not connect the two frames yet!

Qty 17
M6x16 Machine Bolt

Step 1) Determine if you want a Left or Right Return. A Left Return is shown above. Assemble the main desk and return desk frames independently, using a screwdriver.

Step 2

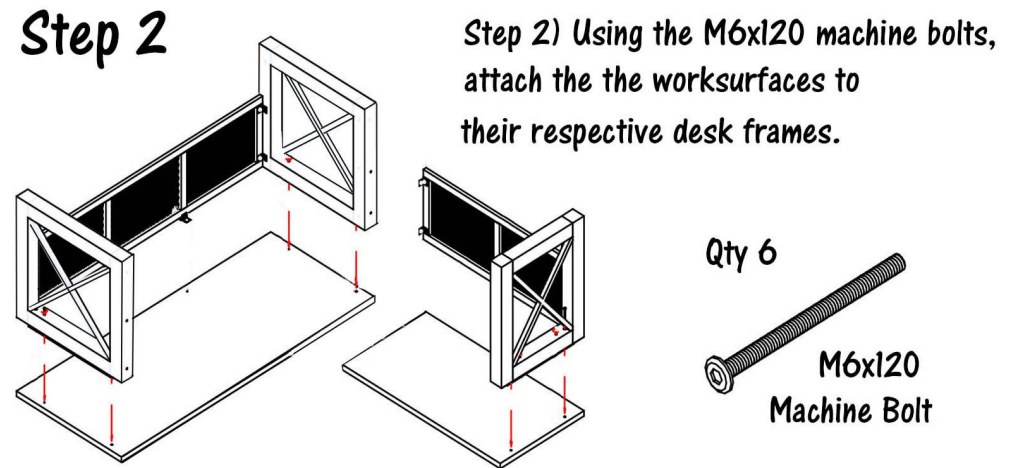

Step 2) Using the M6x120 machine bolts, attach the the worksurfaces to their respective desk frames.

Qty 6
M6x120 Machine Bolt

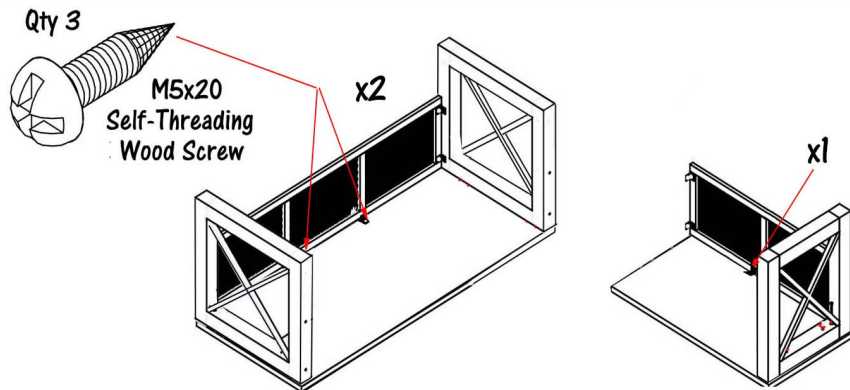

Qty 3
M5x20 Self-Threading Wood Screw
x2

x1

Step 3). Using the M5x20 Self-Threading Wood Screws and a Power Screwdriver, attach the modesty panels to their respective worksurfaces. The screws are self-threading, so you will make your own holes.

Step 4

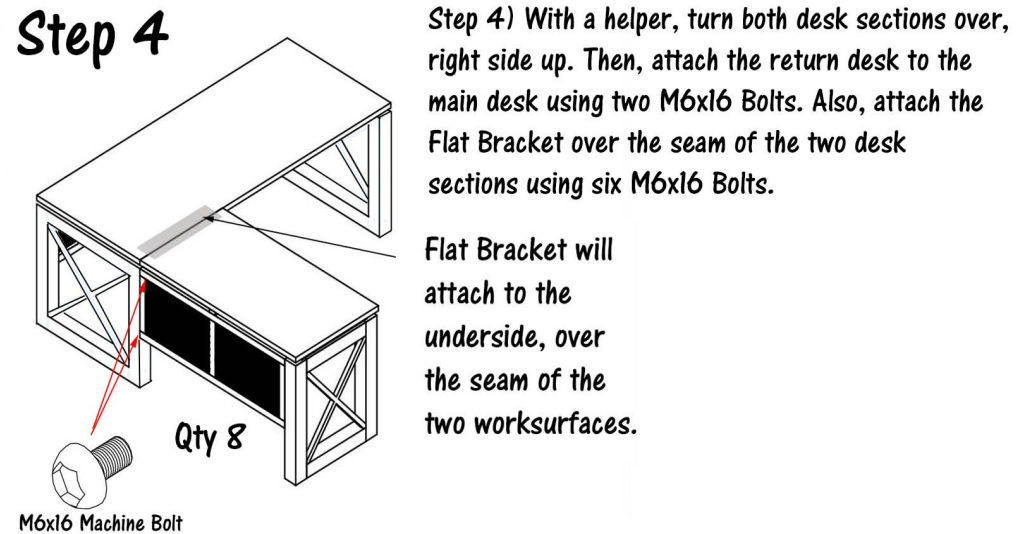

Step 4) With a helper, turn both desk sections over, right side up. Then, attach the return desk to the main desk using two M6x16 Bolts. Also, attach the Flat Bracket over the seam of the two desk sections using six M6x16 Bolts.

Qty 8
M6x16 Machine Bolt

Flat Bracket will attach to the underside, over the seam of the two worksurfaces.

TrendSpaces Desk Series

Hutch Assembly Instructions

for Y11873 U-Desk with Hutch,
Y11133 Wall Mounted Hutch &
Y11134 Desk Mounted Hutch
(1044WS & HUTCHLEGS-SLV)

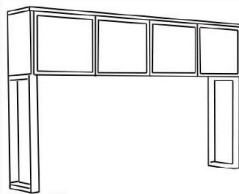

List of Hardware:

Part	Part	Part
		Qty 4
		Qty 4
		Qty 8

Tools Needed:

- Allen Wrench included (to connect bolts)
- Power Screwdriver
- A Helper

1.) Identify the parts of the hutch using Fig 1. Assemble on cardboard or carpet to protect parts during assembly.

2.) Assemble upside down like shown in Fig 1. Attach panels using wood dowels, cam locks and cam pins in the order shown below. LEAVE CAM LOCKS LOOSE DURING ASSEMBLY. FULLY TIGHTEN WHEN ALL PARTS CONNECTED:

- A - Attach Left Side Panel to Top Surface.
- B - Attach Middle Support to Top Surface.
- C - Attach Right Side Panel to Top Surface.
- D - Attach Back Panel to Top Surface, Side Panels and Middle Support.
- E - Attach Bottom Shelf.

3.) You will notice the Back Panel has a pre-installed brace. This is for if you plan to mount your hutch on your wall. There is wood brace included with your hutch that should be installed onto your wall, into your wall studs, with the angled side facing "up".

The preinstalled brace will fit into the wall brace.

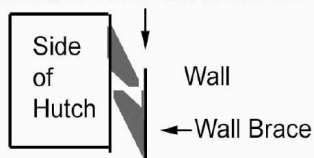
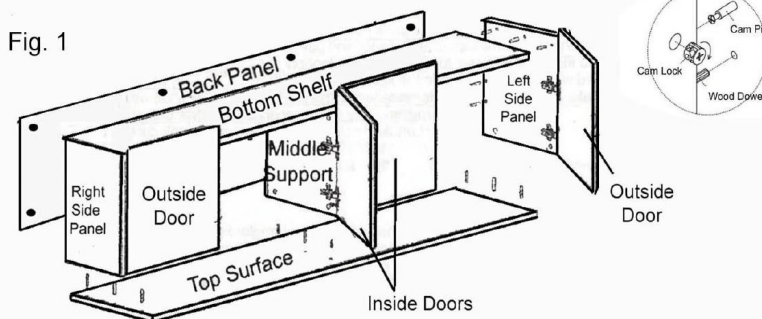

Fig. 1



Special note: wall mounting hardware is not included. Due to the variety in wall and stud material, there is no universal screw that will work with all wall/studs.

Customers to supply own hardware to mount brace.

If you plan to attach the hutch to the desk, go to Step 4. If you plan to mount to the wall, go to Step 6.

4.) Attach hutch legs to the bottom of the hutch using the machine screws, 4 per side.

5.) Next, attach your hutch to its final destination, whether on a credenza for a U-desk or on top of lateral files or open storage units. Use the machine bolts to attach the hutch legs to the pre-drilled inserts on top of the credenza worksurface or lateral files, etc.



Step 8

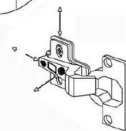

Step 9

6.) Once the hutch is positioned and will no longer need to be moved, it is time to attach the doors. Connect all 8 hinge plates to the inside side panels using the screws provided. LEAVE HINGE PLATES LOOSE!

7.) Next, locate all of the hinges sort out the 'inside door' hinges from the 'outside door' hinges. They look slightly different. See Fig 2. below. The doors are all made the same.

8.) Attach 2 hinges per door. Use the hinges with the 'bump' on the outside left & right doors and the flat hinges on the inside left & right doors. Once hinges are attached, slide the doors/hinges over the hinge plates, fitting the screw head of the hinge plate into the slot of the hinge. Once fitted, tighten the set screw.

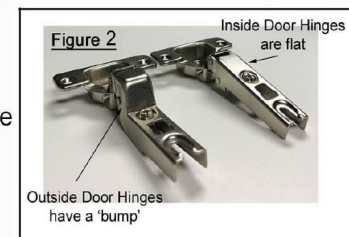

9.) Align the hutch doors by using your screwdriver to adjust the set screw to adjust the depth and screws on the hinge plates to move the door up/down. Once aligned,