

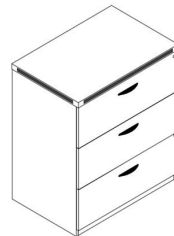

2, 3 & 4 Drawer Lateral File Assembly Instructions

Applies towards:

BK/FL/MJ/ML/WH2012
 WH2012A
 LF3622-MWAL
 LF3622-WH
 WH2012A-3DLF
 FL/MJ/ML/WH2012B

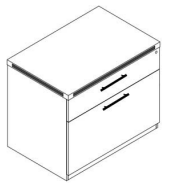
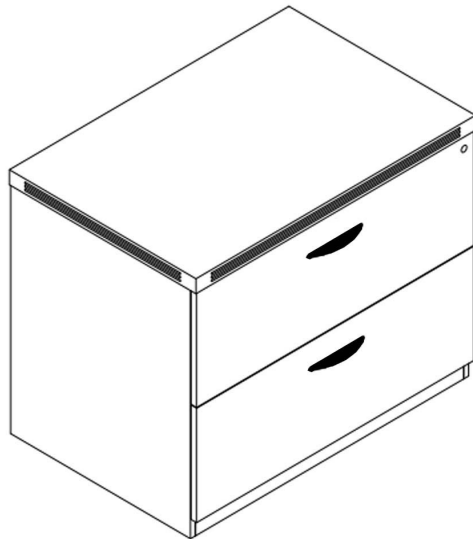

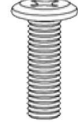
List of Hardware:

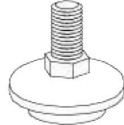
Part	Part
<p>Drawer Pull Screw</p>  <p>2 per drawer pull</p>	<p>Drawer Pull</p>  <p>1 per drawer</p>
 <p>1 set of keys</p>	 <p>4 Leveling Glides</p>

1.) Install 4 leveling glides. Keep the front two leveling glides 1/4" taller than the back back two, which means your file will be slightly tilted back. This is the proper way to level a lateral file cabinet. It keeps any unlocked file drawers from creeping open and distributes the weight more evenly.

2.) Use the screws to attach drawer pulls.

Questions? Please call 1-800-443-5117.

Customer Service available 8:30 - 5:00 Central Time, Monday - Friday



36"W Metal Hutch Assembly Instructions

Questions: Call 1-800-443-5117, 8:30-5, Central Time, Mon-Fri

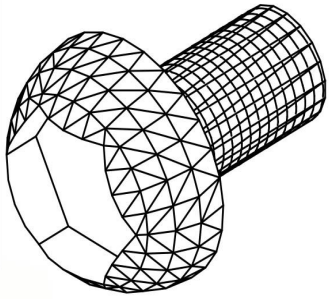

M16 Machine Bolts
Qty 20

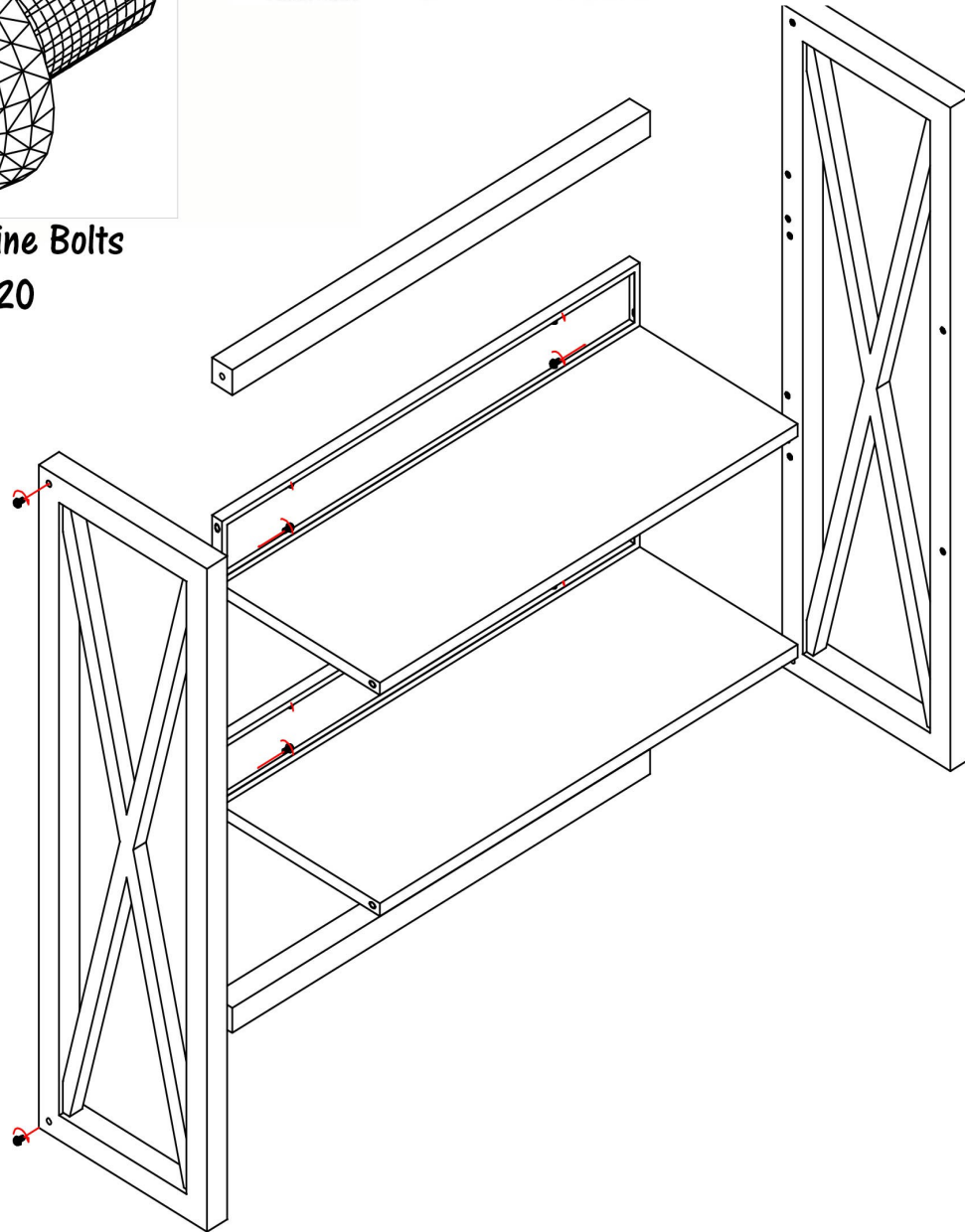

Step 1) Assemble on carpet or cardboard to protect during assembly.

Step 2) Start with one Side Frame and attach all shelves and cross beams, starting with the bottom cross beam and assembling the shelves and other beams from there. Use the M16 Bolts and Allen Wrench Included.

Step 3) Attach the other Side Panel using same hardware.

Step 4) Optional: Double Sided Tape is pre-applied to the bottom of the side panels. To secure to your surface, peel off the back and carefully place the hutch onto the surface.

