

Y13837

Industrial Series 71"W x 107"D Executive Black Metal Frame
U-Shaped Desk w/ Electric Lift Bridge & Hutch

Assembly Instructions



Questions? Customer Service is available 8:30-5, Central Time, Monday-Friday. Call 800-443-5117 or email CustomerSvc@ModernOfficeFurniture.com

Industrial Desk Assembly Instructions

Questions: Call 1-800-443-5117, 8:30-5, Central Time, Mon-Fri

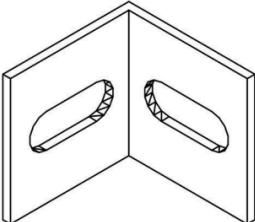
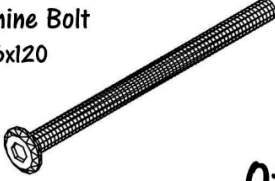
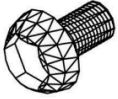
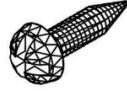
<p>L-Shaped Bracket</p>  <p>Qty 6</p>	<p>Machine Bolt M6x120</p>  <p>Qty 4</p>	<p>Machine Bolt M6x16</p>  <p>Qty 10</p>	<p>Self-Threading Wood Screw M5x20</p>  <p>Qty 2</p>
--	--	---	---

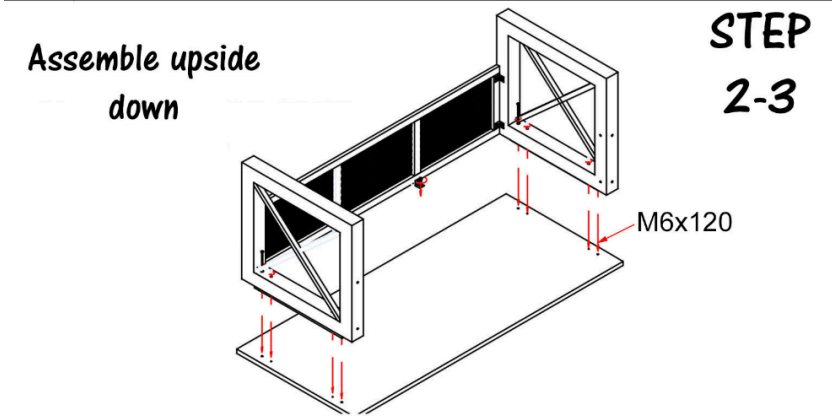
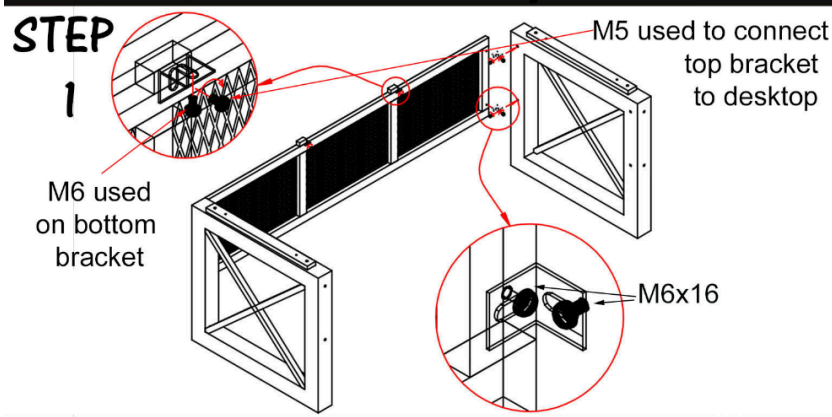

Step 1) With a screwdriver, assemble the desk frame with the L-Shaped Brackets and M6x16 machine bolts.

Step 2) Use the M6x120 machine bolts to attach the desktop to the metal frame.

Step 3) Use the M5 Self-Threading Wood Screws and a Power Screwdriver to attach the top of the L-Brackets on the modesty panel to the desktop. The self-threading screws make their own holes as you drill.

To attach the laminate bridge surface to the electric lift, you will be using the included wood screws. These are included with the electric lift frame. You will be drilling your own holes with this step. Please disregard the inserts in the 48"x24" surface, they do not pertain to the electric lift frame. See instructions below for assembling frame & attaching the surface.

Item No.: ET223-BLACK

Installation guide

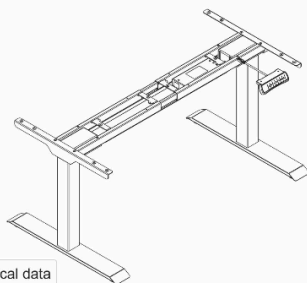

Technical data

Column Stage	3
Max. Weight Capacity	125KG
Height Range	580-1230mm
Width Range	1100-1900mm

Accessory list

Attention: The drawings below are for guidance only and they may differ slightly from the product and fittings received. Please contact our customer service department should you have any queries.

No.	Image	Spec	Qty
A		M6	4
B		M6	4
C		M6	8
D		M6	12
E		S14.2	16
F		Allen Key 4x4mm	1

Component list

No.	Part	Qty	No.	Part	Qty
1	Feet	2	2	Lifting Column	2
3	Cable Management Tray	1	4	Supporting Beam	1
5	Side Bracket	2	6	Hand Switch (Option)	1
7	Control Box	1	8	Power Plug	1

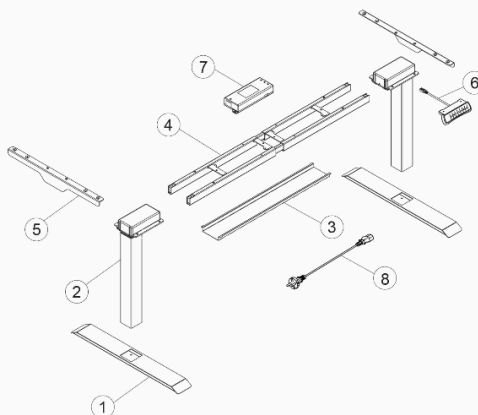

STEP 1

Install the Side Brackets

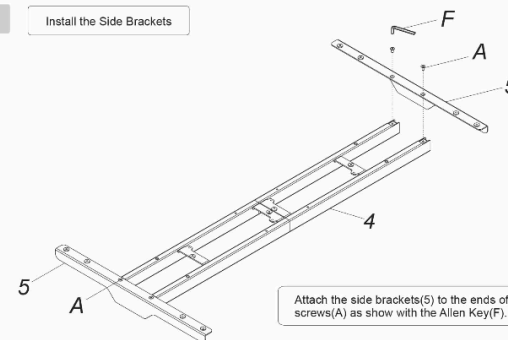

Attach the side brackets(5) to the ends of the supporting beam (4) using screws(A) as show with the Allen Key(F).

STEP 2

Install the Lifting Columns

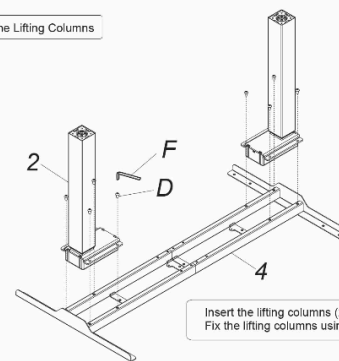

Insert the lifting columns (2) into the ends of the supporting beam(4). Fix the lifting columns using screws(D) with the Allen Key(F).

STEP 3

Install the Feet

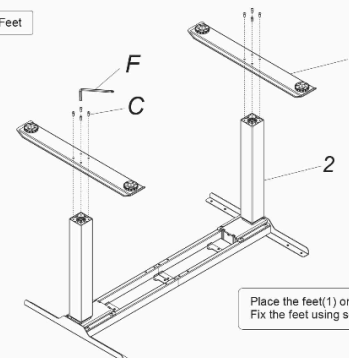

Place the feet(1) on the bottom of the lifting column(2). Fix the feet using screws(C) with Allen Key(F).

STEP 4

Install the Tabletop



1

Center the top on the base and use the wood screws to drill the top into the base. There are no piloted holes for this step. The wood screws are self-drilling so you will be making your own holes.

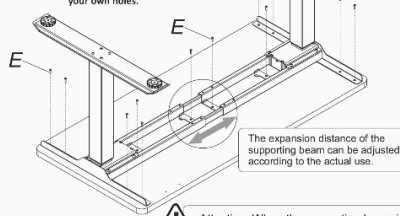

The expansion distance of the supporting beam can be adjusted according to the actual use.

Attention: When the supporting beam is greater than 1720mm, the installation method is as follows: Method 2 in Step 6.

2

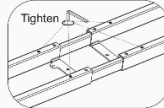
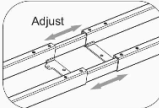

STEP 5

Install the Control Panel and the Control Box

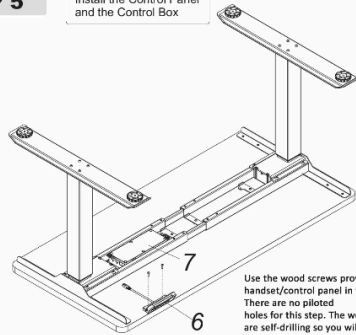

Use the wood screws provided to attach handset/control panel in your preferred spot. There are no piloted holes for this step. The wood screws are self-drilling so you will be making your own holes.

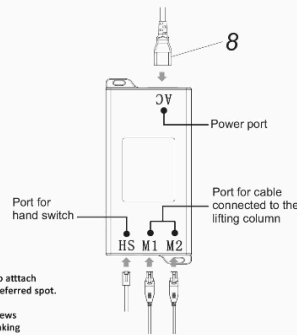

STEP 6

Install the Cable Management Tray



Method 1

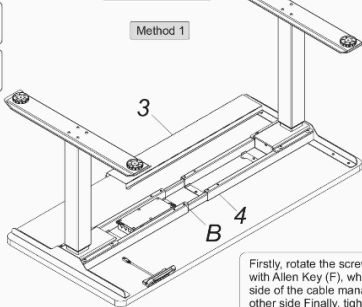

Firstly, rotate the screws (B) incompletely into the supporting beam (4) with Allen Key (F), which means do not tighten them. Next, slide one side of the cable management tray (3) into the screws (B), then the other side. Finally, tighten the screws (B) with Allen Key (F).

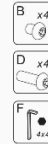
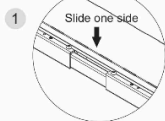

Method 2

Install the cable management tray as Method 1, Step 6.

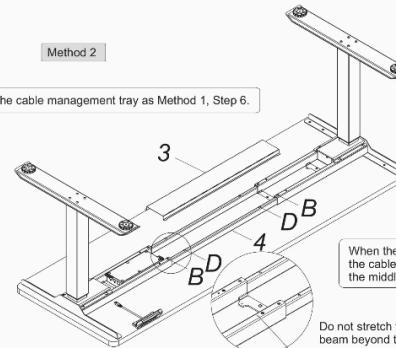

When the supporting beam stretches over 1720 mm, the cable management tray needs to be mounted on the middle of the supporting beam.

Do not stretch the support beam beyond this hole.

Common fault treatment

The following tips will help you detected and eliminate the common fault and error. If the fault you met is not listed below, please contact with your supplier. Only the manufacturer and professionals are capable for investigating and correcting those fault and error.

Fault phenomenon	Method
No response while long pressing down arrow after connected with a power supply	1. Check if all the cables be connected well 2. Contact your supplier or dealer
No response while pressing up arrow down arrow after connected with a power supply	1. Check if all the cables be connected well 2. Contact your supplier or dealer
Rising in a low speed	1. Check if overloaded, max loading: 125kg. 2. Contact your supplier or dealer
The motor not move as instructed	1. Contact your supplier or dealer
Go down but not go up	1. Reposition 2. Contact your supplier or dealer
Downward sliding	1. Check if overloaded, max loading: 125kg. 2. Contact your supplier or dealer
Frequently Reposition	1. Check if overloaded, max loading: 125kg. 2. Contact your supplier or dealer
Overwork (Duty cycle: Max 2min on 1 5min OFF)	1. Restart after suspend for 18mins while connecting with power. 2. Contact your supplier or dealer.
Not enough up&down height	1. Press "M" and "S" together for 3 seconds or more, after hearing continuous beeping for twice, it will restore factory settings 2. Contact your supplier or dealer

Attention

- Power supply: AC100V-240V, 50/60Hz
- Service Environment: 0-40°C
- Unplug the power plug before cleaning, wipe the dust on surface with slight wet dishcloth when cleaning, be careful not to let the drops into the internal parts, not loose the connector.
- The electric box contains electronic components, metals, plastics, wires etc., so dispose of it in accordance with each country's environmental legislation, not the general household waste.
- Check carefully to ensure correct and complete assembly before using.
- Be familiar with all functions and program settings of the product before first use.
- Children are forbidden to play on the product because of unforeseen action when playing, so any dangerous consequences caused by this improper action will not be on.
- Slight noise caused by the V-ribbed belt or brake system due to structure will not have any effect on the use of the equipment.
- Corrosive or abrasive materials are forbidden to clean the equipment. Must ensure that the cleaner used will not pollute the environment.
- This appliance can be used by children aged from 8 years and above and persons with reduced physical, sensory or mental capabilities or lack of experience and knowledge if they have been given supervision or instruction concerning use of the appliance in a safe way and understand the hazards involved. Children shall not play with the appliance.
- Cleaning and user maintenance shall not be made by children without supervision.
- If the supply cord is damaged, it must be replaced by the manufacturer, its service agent or a similarly qualified person in order to avoid a hazard.
- Please make sure there is no hazard sources in your operating environment, e.g., do not litter the tools around. Always be careful to treat the packaging materials in order to avoid any possible danger, e.g. plastic bag may lead to choking hazard to children.
- Keep the original package of the equipment if necessary in case of the future use in transportation.

Waste disposal



This marking indicates that this product should not be disposed with other household wastes. To prevent possible harm to the environment or human health from uncontrolled waste disposal, recycle it responsibly to promote the sustainable reuse of material resources. To return your used device, please use the return and collection systems or contact the retailer where the product was purchased. They can take this product for environmental safe recycling.

Questions? Please call 1-800-443-5117.
Customer Service available 8:30 - 5:00 Central Time, Monday - Friday

Handset Operation Guide

1. Product Outline

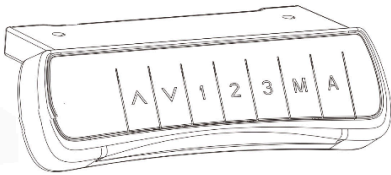

Questions? Call 1-800-443-5117 Mon-Fri, 8:30-5PM CT

2. Product Specification

Button introduction: There are seven buttons that "▲", "▼", "1", "2", "3", "M", "A"

- (1) "▲" : Adjust the desk upwards
- (2) "▼" : Adjust the desk downwards
- (3) "1" : Position 1, first height position saved by the user
- (4) "2" : Position 2, second height position saved by the user
- (5) "3" : Position 3, third height position saved by the user
- (6) "M" : Height memory function
- (7) "A" : Alert button to remind users changing posture

3. Operating Instructions

- Height Adjustable Function:
Press the "▲" or "▼" button to adjust the height. The LED display shows the current height.
- Height Memory Function:
 - a. Press UP or DOWN button and adjust the height to the desired height. Press "M" to save the height, and the screen will display "5-"; Press "1", "2", or "3" then, that is, save the height to the corresponding position 1 or 2 or 3, which will show in the display screen as "5-1", "5-2", or "5-3";
 - b. Press "1", "2" and "3" button directly to automatically adjust the memory height you saved.

- Reminder Function:
 - a. Press REMINDER button "A" to activate the function. The LED display shows "00" or "0n".
 - b. Two seconds later, press the "▲" or "▼" button to adjust the reminder time only when the display screen flashes. The default time of the reminder is 45 minutes, which is shown as "45". Then press any button to save the time setup, or wait 5 seconds and system will save the time setup automatically. During the countdown, any operation will lead to a repeat starting of the timer. When the countdown finishes, display screen will show "00" the buzzer will be active with a 10-second "DiDi...DiDi..."tone.
 - c. Within the 10-second reminder buzz, press any button to reactivate the time countdown that is set up in (b) step. If no operation during the 10-second reminder buzz, there will be another reminder buzz after 5 minutes. No operation during the second buzz will turn off the Long-Time Sitting Reminder.
 - d. Press and hold the "A" button for three seconds to turn off the Long-Time Sitting Reminder. The LED display shows "FF" or "oFF".
- Anti-collision sensitivity adjustment - optional features:
 - a. Press and hold the "▲" "▼" button for 5 seconds at the same time to switch the sensitivity. Switch one level for 1 time and divide it into 4 levels (A-3, A-2, A-1, A-0);
 - b. The display shows "0-0", the anti-collision function is off; the display shows "0-1", low sensitivity; Display shows "0-2", medium sensitivity; display shows "0-3", high sensitivity;
 - c. During height adjustment, when tabletop comes in contact with another object, it instantly stops and reverses to avoid damage.
 - d. Press and hold the "▲" "▼" button for 5 seconds at the same time. If the display does not display the above code, there is no anti-collision function.
- Troubleshooting:
 - a. When the LED display shows "R5f" or "r5t", long press the "▼" button, the standing desk runs to the lowest or highest position and then runs in reverse until it stops, at this time the display shows the height number, release the "▼" button, after the reset, the desk can be used normally;
 - b. When it doesn't work and the LED shows "E01" or "E02", please retry 18 minutes later.
 - c. If the "▼" button doesn't work, please check the cable connection and then cut off the power for at least 10 seconds. Reconnect to the power, showing "R5f" or "r5t" and then long press the "▼" button to start the reset process.
 - d. If you perform the above operations, the desk still does not work properly, please contact customer service.

Waste disposal



This marking indicates that this product should not be disposed with other household wastes. To prevent possible harm to the environment or human health from uncontrolled waste disposal, recycle it responsibly to promote the sustainable reuse of material resources. To return your used device, please use the return and collection systems or contact the retailer where the product was purchased. They can take this product for environmental safe recycling.

TrendSpaces Desk Series
Hutch Assembly Instructions
for Y11873 U-Desk with Hutch,
Y11133 Wall Mounted Hutch &
Y11134 Desk Mounted Hutch
(1044WS & HUTCHLEGS-SLV)

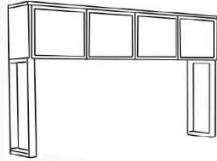

List of Hardware:

Part	Part	Part
Wood Dowel	Cam Lock Cap	Qty 4 Outside Door Hinge
Cam Pin	Machine Screw	Qty 4 Inside Door Hinge
Cam Lock		Qty 8 Hinge Plate

Tools Needed:

- Allen Wrench included (to connect bolts)
- Power Screwdriver
- A Helper

1.) Identify the parts of the hutch using Fig 1. Assemble on cardboard or carpet to protect parts during assembly.

2.) Assemble upside down like shown in Fig 1. Attach panels using wood dowels, cam locks and cam pins in the order shown below. LEAVE CAM LOCKS LOOSE DURING ASSEMBLY. FULLY TIGHTEN WHEN ALL PARTS CONNECTED:

- A - Attach Left Side Panel to Top Surface.
- B - Attach Middle Support to Top Surface.
- C - Attach Right Side Panel to Top Surface.
- D - Attach Back Panel to Top Surface, Side Panels and Middle Support.
- E - Attach Bottom Shelf.

3.) You will notice the Back Panel has a pre-installed brace. This is for if you plan to mount your hutch on your wall. There is wood brace included with your hutch that should be installed onto your wall, into your wall studs, with the angled side facing "up". The preinstalled brace will fit into the wall brace.

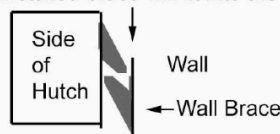
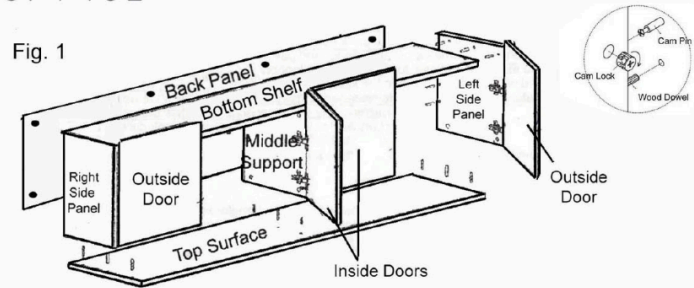

Fig. 1



Special note: wall mounting hardware is not included. Due to the variety in wall and stud material, there is no universal screw that will work with all wall/studs. Customers to supply own hardware to mount brace.

If you plan to attach the hutch to the desk, go to Step 4. If you plan to mount to the wall, go to Step 6.

- 4.) Attach hutch legs to the bottom of the hutch using the machine screws, 4 per side.
- 5.) Next, attach your hutch to its final destination, whether on a credenza for a U-desk or on top of lateral files or open storage units. Use the machine bolts to attach the hutch legs to the pre-drilled inserts on top of the credenza worksurface or lateral files, etc.

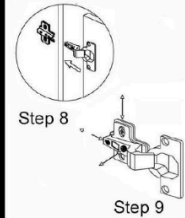

6.) Once the hutch is positioned and will no longer need to be moved, it is time to attach the doors. Connect all 8 hinge plates to the inside side panels using the screws provided. LEAVE HINGE PLATES LOOSE!

7.) Next, locate all of the hinges sort out the 'inside door' hinges from the 'outside door' hinges. They look slightly different. See Fig 2. below. The doors are all made the same.

8.) Attach 2 hinges per door. Use the hinges with the 'bump' on the outside left & right doors and the flat hinges on the inside left & right doors. Once hinges are attached, slide the doors/hinges over the hinge plates, fitting the screw head of the hinge plate into the slot of the hinge. Once fitted, tighten the set screw.

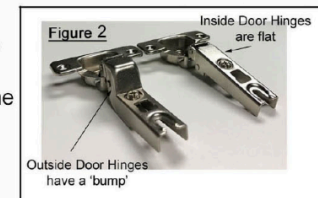

9.) Align the hutch doors by using your screwdriver to adjust the set screw to adjust the depth and screws on the hinge plates to move the door up/down. Once aligned,