



Y13859 – Assembly Instructions

Xdustrial Series 71"W x 108"D Solid Wood U-Shaped Desk with Elec. Lift Bridge

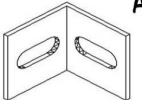
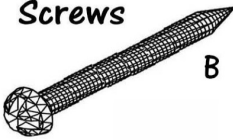

Questions? Call 1-800-443-5117, Mon-Fri 8:30-5PM,
Central Time

Industrial Solid Beech Office Desk Assembly Instructions

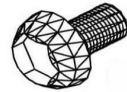
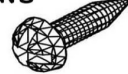
Brackets  A	4.5" Wood Screws  B	Washers  D	Machine Screws  E	.75" Wood Screws  F
12	8	8	20	4

Assembly Instructions for the front desk and back desk for the Y13859 U-Desk with Electric Lift Bridge. Both desks assemble in same way.

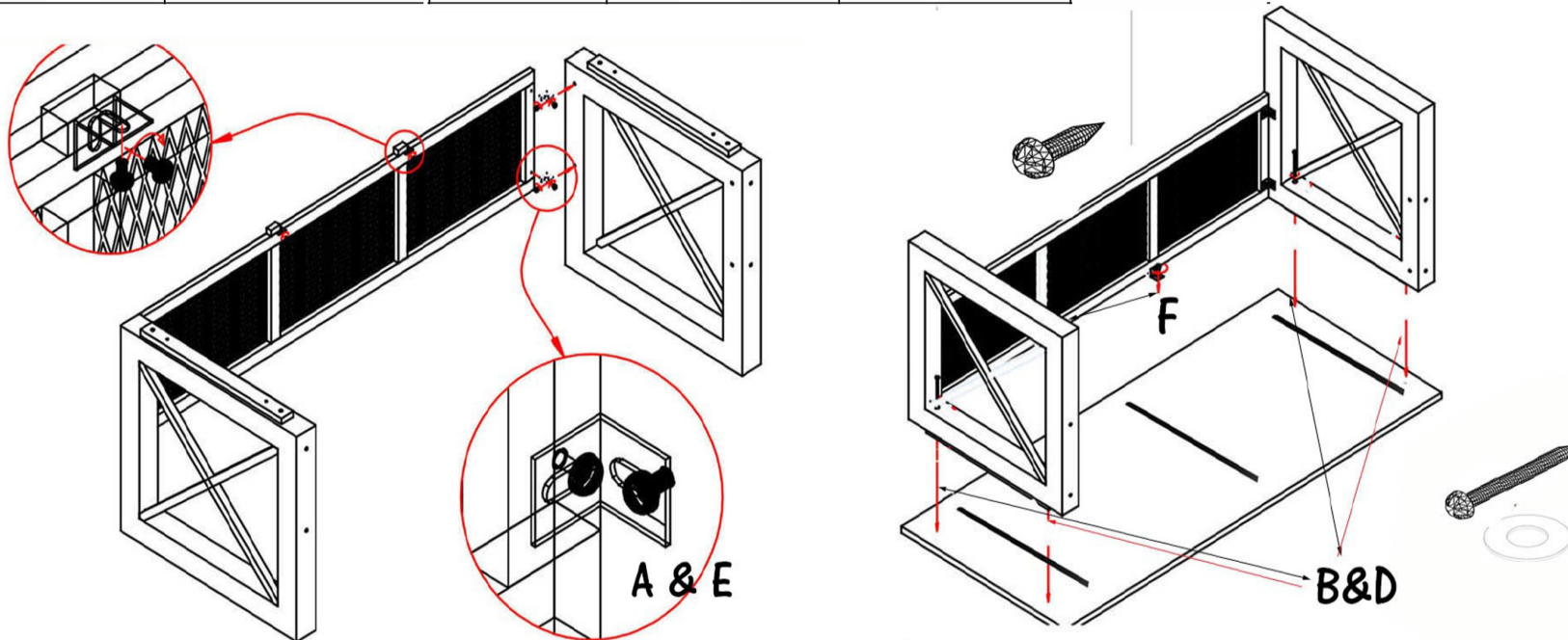

Tools You Will Need: A Screwdriver, Power Screwdriver and a Helper. (Allen Wrenches included already for Machine Bolts)

For Desks:

Tip: Assembly on carpet or cardboard for protection during assembly.

- 1) Assemble the desk frame right side up. Then, once assembled, flip upside down to attach the desk top.
- 2) Use a Power Screwdriver to install Wood Screws and Washers. These screws are self-threading so you will be making your own holes.
- 3) Once attached, with a helper, turn desk right side up.

To attach the solid wood bridge desk top to the electric lift frame, use wood screws included with electric lift to make your own holes and attach.

Item No.: ET223-BLACK
Installation guide

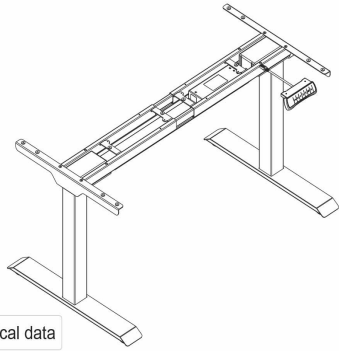







Technical data

Column Stage	3
Max. Weight Capacity	125KG
Height Range	580-1230mm
Width Range	1100-1900mm

Accessory list

Attention: The drawings below are for guidance only and they may differ slightly from the product and fittings received. Please contact our customer service department should you have any queries.

No.	Image	Spec	Qty
A		M6	4
B		M6	4
C		M6	8
D		M6	12
E		S14.2	16
F		Allen Key 4x4mm	1

Component list

No.	Part	Qty	No.	Part	Qty
①	Feet	2	②	Lifting Column	2
③	Cable Management Tray	1	④	Supporting Beam	1
⑤	Side Bracket	2	⑥	Hand Switch (Option)	1
⑦	Control Box	1	⑧	Power Plug	1

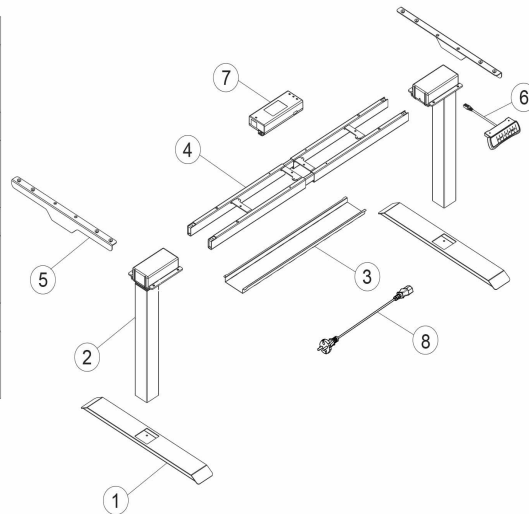

STEP 1

Install the Side Brackets

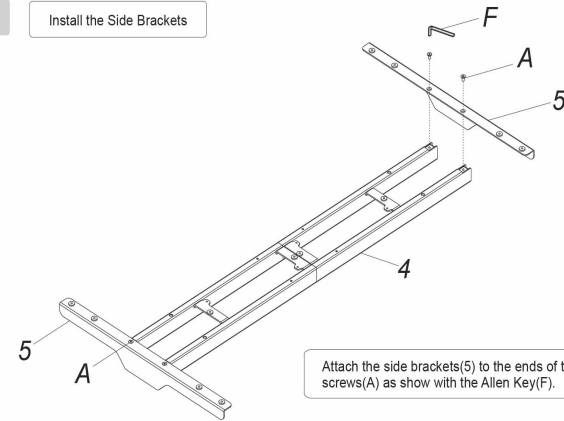

Attach the side brackets(5) to the ends of the supporting beam (4) using screws(A) as show with the Allen Key(F).

STEP 2

Install the Lifting Columns

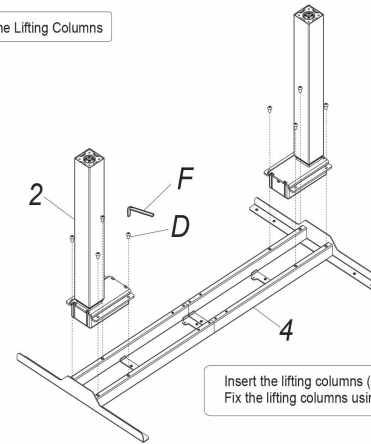

Insert the lifting columns (2) into the ends of the supporting beam(4). Fix the lifting columns using screws(D) with the Allen Key(F).

STEP 3

Install the Feet

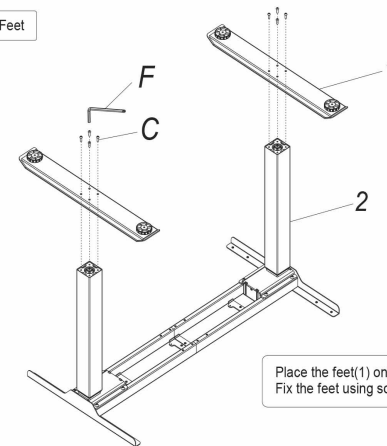

Place the feet(1) on the bottom of the lifting column(2). Fix the feet using screws(C) with Allen Key(F).

STEP 4

Install the Tabletop

Center the top on the base and use the wood screws to drill the top into the base. There are no piloted holes for this step. The wood screws are self-drilling so you will be making your own holes.

1

E x12

The expansion distance of the supporting beam can be adjusted according to the actual use.

2

Loosen

Adjust

Tighten

F x4

Attention: When the supporting beam is greater than 1720mm, the installation method is as follows: Method 2 in Step 6.

Method 2

Install the cable management tray as Method 1, Step 6.

3

4

B x4

D x4

F x4

When the supporting beam stretches over 1720 mm, the cable management tray needs to be mounted on the middle of the supporting beam.

Do not stretch the support beam beyond this hole

STEP 5

Install the Control Panel and the Control Box

7

6

Use the wood screws provided to attach handset/control panel in your preferred spot. There are no piloted holes for this step. The wood screws are self-drilling so you will be making your own holes.

8

Power port

Port for hand switch

Port for cable connected to the lifting column

HS M1 M2

Common fault treatment

The following tips will help you detect and eliminate the common fault and error. If the fault you met is not listed below, please contact with your supplier. Only the manufacturer and professionals are capable for investigating and correcting those fault and error.

Fault phenomenon	Method
No response while long pressing down arrow after connected with a power supply	1. Check if all the cables be connected well 2. Contact your supplier or dealer
No response while pressing up arrow/down arrow after connected with a power supply	1. Check if all the cables be connected well 2. Contact your supplier or dealer
Rising in a low speed	1. Check if overloaded, max loading: 125kg; 2. Contact your supplier or dealer
The motor not move as instructed	1. Contact your supplier or dealer 1. Reposition
Go down but not go up	2. Contact your supplier or dealer
Downward sliding	1. Check if overloaded, max loading: 125kg; 2. Contact your supplier or dealer
Frequently Reposition	1. Check if overloaded, max loading: 125kg; 2. Contact your supplier or dealer
Overwork (Duty cycle: Max 2min on/18min OFF)	1. Restart after suspend for 18mins while connecting with power; 2. Contact your supplier or dealer;
Not enough up&down height	1. Press "M" and "3" together for 3 seconds or more, after hearing continuous beeping for twice, it will restore factory settings. 2. Contact your supplier or dealer

Attention

- Power supply: AC100V-240V,50/60Hz
- Service Environment: 0-40°C
- Unplug the power plug before cleaning, wipe the dust on surface with slight wet dishcloth when cleaning, be careful not to let the drops into the internal parts, not loose the connector.
- The electric box contains electronic components, metals, plastics, wires etc., so dispose of it in accordance with each country's environmental legislation, not the general household waste.
- Check carefully to ensure correct and complete assembly before using.
- Be familiar with all functions and program settings of the product before first use.
- Children are forbidden to play on the product because of unforeseen action when playing, so any dangerous consequences caused by this improper action will not be on
- Slight noise caused by the V-ribbed belt or brake system due to structure will not have any effect on the use of the equipment.
- Corrosive or abrasive materials are forbidden to clean the equipment. Must ensure that the cleaner used will not pollute the environment.
- This appliance can be used by children aged from 8 years and above and persons with reduced physical, sensory or mental capabilities or lack of experience and knowledge if they have been given supervision or instruction concerning use of the appliance in a safe way and understand the hazards involved. Children shall not play with the appliance.
- Cleaning and user maintenance shall not be made by children without supervision.
- If the supply cord is damaged, it must be replaced by the manufacturer, its service agent or a similarly qualified person in order to avoid a hazard.
- Please make sure there is no hazard sources in your operating environment, e.g., do not litter the tools around. Always be careful to treat the packaging materials in order to avoid any possible danger, e.g. plastic bag may lead to choking hazard to children.
- Keep the original package of the equipment if necessary in case of the future use in transportation.

STEP 6

Install the Cable Management Tray

Method 1

3

4

B x4

F x4

1 Slide one side

2 Buckle the other side

3 Tighten

Firstly, rotate the screws (B) incompletely into the supporting beam (4) with Allen Key (F), which means do not tighten them. Next, slide one side of the cable management tray (3) into the screws (B), then the other side. Finally, tighten the screws (B) with Allen Key (F).

Waste disposal

This marking indicates that this product should not be disposed with other household wastes. To prevent possible harm to the environment or human health from uncontrolled waste disposal, recycle it responsibly to promote the sustainable reuse of material resources. To return your used device, please use the return and collection systems or contact the retailer where the product was purchased. They can take this product for environmental safe recycling.

Questions? Please call 1-800-443-5117.
Customer Service available 8:30 - 5:00 Central Time, Monday - Friday

Handset Operation Guide

1. Product Outline

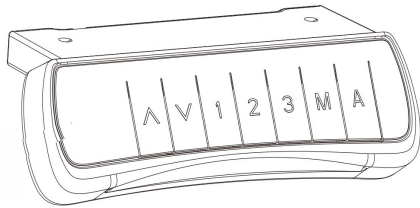

Questions? Call 1-800-443-5117 Mon-Fri, 8:30-5PM CT

2. Product Specification

Button introduction: There are seven buttons that "▲", "▼", "1", "2", "3", "M", "A"

- (1) "▲" : Adjust the desk upwards
- (2) "▼" : Adjust the desk downwards
- (3) "1" : Position 1, first height position saved by the user
- (4) "2" : Position 2, second height position saved by the user
- (5) "3" : Position 3, third height position saved by the user
- (6) "M" : Height memory function
- (7) "A" : Alert button to remind users changing posture

3. Operating Instructions

- Height Adjustable Function:
Press the "▲" or "▼" button to adjust the height. The LED display shows the current height.
- Height Memory Function:
 - a. Press UP or DOWN button and adjust the height to the desired height. Press "M" to save the height, and the screen will display "5-"; Press "1", "2", or "3" then, that is, save the height to the corresponding position 1 or 2 or 3, which will show in the display screen as "5-1", "5-2", or "5-3";
 - b. Press "1", "2" and "3" button directly to automatically adjust the memory height you saved.

- Reminder Function :
 - a. Press REMINDER button "A" to activate the function. The LED display shows "00" or "on".
 - b. Two seconds later, press the "▲" or "▼" button to adjust the reminder time only when the display screen flashes. The default time of the reminder is 45 minutes, which is shown as "45". Then press any button to save the time setup, or wait 5 seconds and system will save the time setup automatically. During the countdown, any operation will lead to a repeat starting of the timer. When the countdown finishes, display screen will show "00" the buzzer will be active with a 10-second "DiDi...DiDi...DiDi..."tone.
 - c. Within the 10-second reminder buzz, press any button to reactivate the time countdown that is set up in (b) step. If no operation during the 10-second reminder buzz, there will be another reminder buzz after 5 minutes. No operation during the second buzz will turn off the Long-Time Sitting Reminder.
 - d. Press and hold the "A" button for three seconds to turn off the Long-Time Sitting Reminder. The LED display shows "0FF" or "oFF".
- Anti-collision sensitivity adjustment - optional features:
 - a. Press and hold the "▲" "▼" button for 5 seconds at the same time to switch the sensitivity. Switch one level for 1 time and divide it into 4 levels (A-3, A-2, A-1, A-0);
 - b. The display shows "0-0", the anti-collision function is off; the display shows "0-1", low sensitivity; Display shows "0-2", medium sensitivity; display shows "0-3", high sensitivity;
 - c. During height adjustment, when tabletop comes in contact with another object, it instantly stops and reverses to avoid damage.
 - d. Press and hold the "▲" "▼" button for 5 seconds at the same time. If the display does not display the above code, there is no anti-collision function.
- Troubleshooting:
 - a. When the LED display shows "E5f" or "r5t", long press the "▼" button, the standing desk runs to the lowest or highest position and then runs in reverse until it stops, at this time the display shows the height number, release the "▼" button, after the reset, the desk can be used normally;
 - b. When it doesn't work and the LED shows "E01" or "E02", please retry 18 minutes later.
 - c. If the "▼" button doesn't work, please check the cable connection and then cut off the power for at least 10 seconds. Reconnect to the power, showing "E5f" or "r5t" and then long press the "▼" button to start the reset process.
 - d. If you perform the above operations, the desk still does not work properly, please contact customer service.

Waste disposal



This marking indicates that this product should not be disposed with other household wastes. To prevent possible harm to the environment or human health from uncontrolled waste disposal, recycle it responsibly to promote the sustainable reuse of material resources. To return your used device, please use the return and collection systems or contact the retailer where the product was purchased. They can take this product for environmental safe recycling.