



Model #: Y14341

Description: Big & Tall Chair

Assembly & Operating Instructions



www.modernofficefurniture.com

Customer Service

Tel:1-800-443-5117 8:30AM to 5PM M-F Central



Please read the instruction sheet(s) completely before assembly.

Maximum Weight Load: 400 LBS

Before You Begin

Please identify all component parts and hardware pieces required before you begin. Carefully remove all of the components from the packing and set aside for assembly. Assemble on a soft surface to prevent scratching during assembly.

Caution:

Tighten all components securely before use.
Failure to do so may result in personal injury.
DO NOT use any sharp objects to open plastic wrapped components as damage to product or components may result.
For best user safety, conduct regular check of nuts and bolts to insure they are always tight and secure.





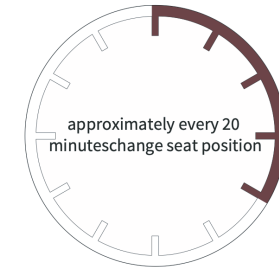
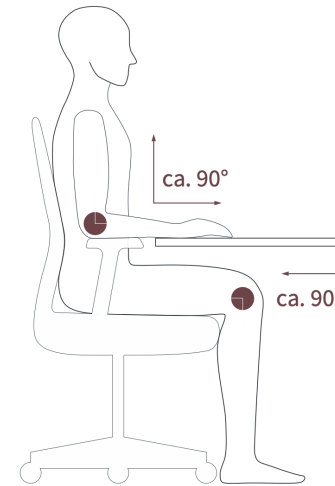

Warning:

CHOKING HAZARD - Small Parts. Adult Assembly Required.
DO NOT ALLOW CHILDREN TO CLIMB ON FURNITURE.

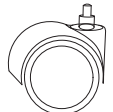
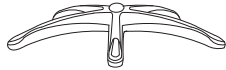

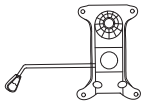

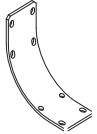

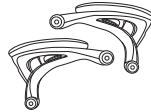
Position chair so your feet are flat on the floor, and lower legs are at a 90-degree angle (or better) relative to upper legs.

Part List

<p>①</p>  <p>Casters x 5</p>	<p>②</p>  <p>Base x 1</p>	<p>③</p>  <p>Cylinder Cover x 1</p>
<p>④</p>  <p>Cylinder x 1</p>	<p>⑤</p>  <p>Mechanism x 1</p>	<p>⑥</p>  <p>Seat x 1</p>
<p>⑦</p>  <p>Steel Plate x 1</p>	<p>⑧</p>  <p>Back x 1</p>	<p>⑨</p>  <p>Arms x 1</p>

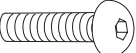
Hardware List

<p>A</p> 	<p>M6*25mm x 4pcs</p>	<p>B</p> 	<p>M6*30mm x 8pcs</p>
<p>C</p> 	<p>M8*40mm x 4pcs</p>	<p>D</p> 	<p>Allen Wrench x 1 pc</p>
<p>E</p> 	<p>Screw Caps 4pcs</p>		

Installation Steps

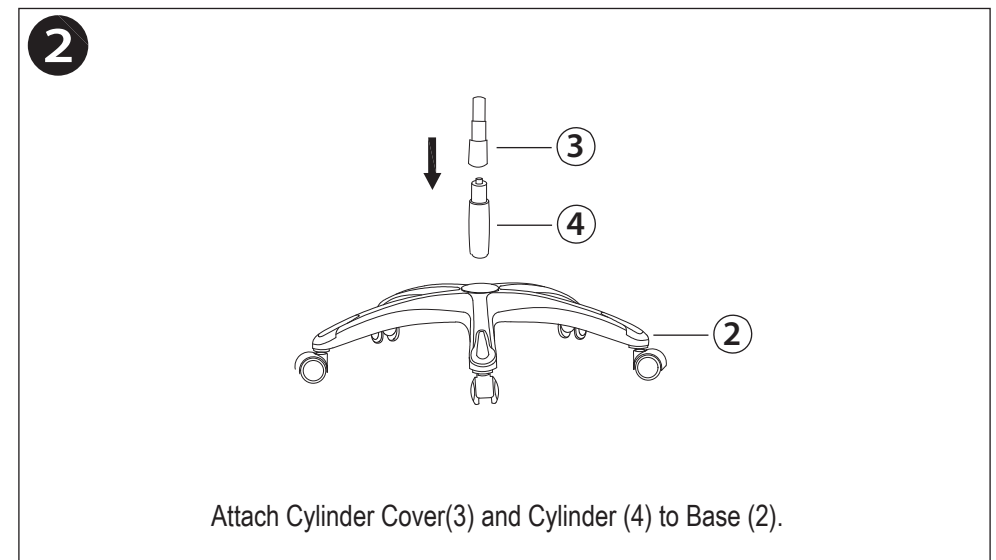
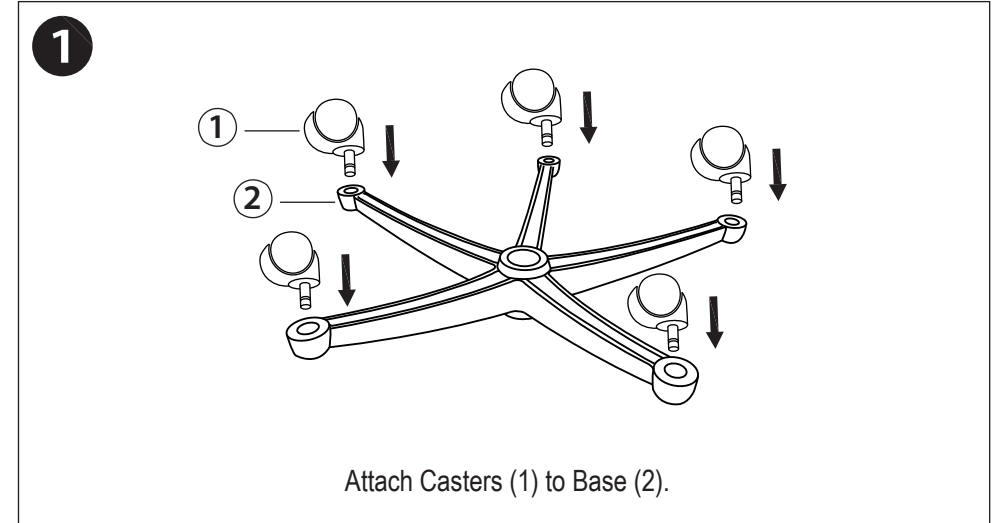

Installation Steps

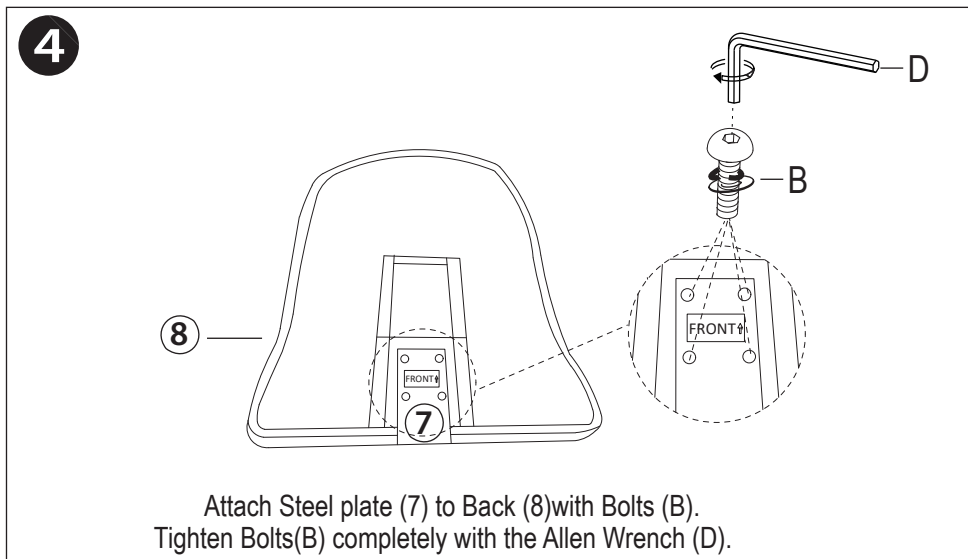
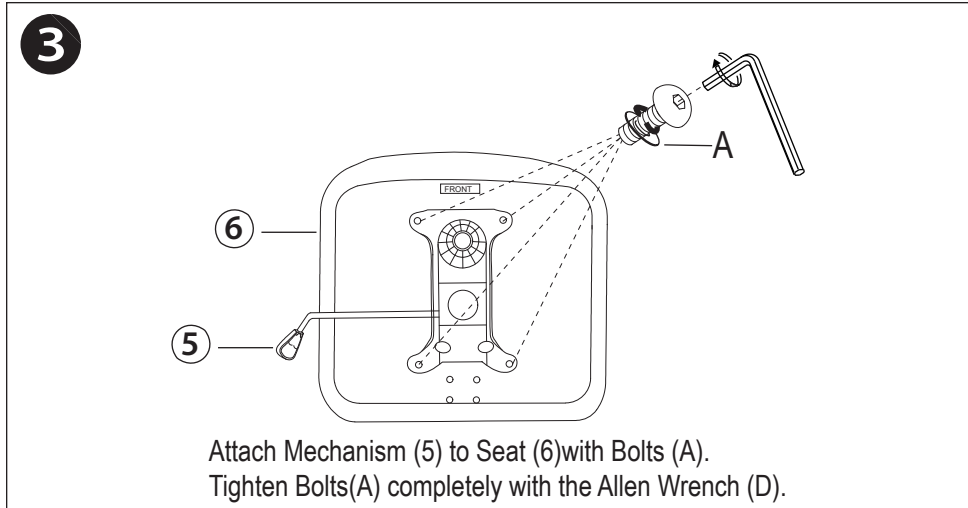

Installation Steps

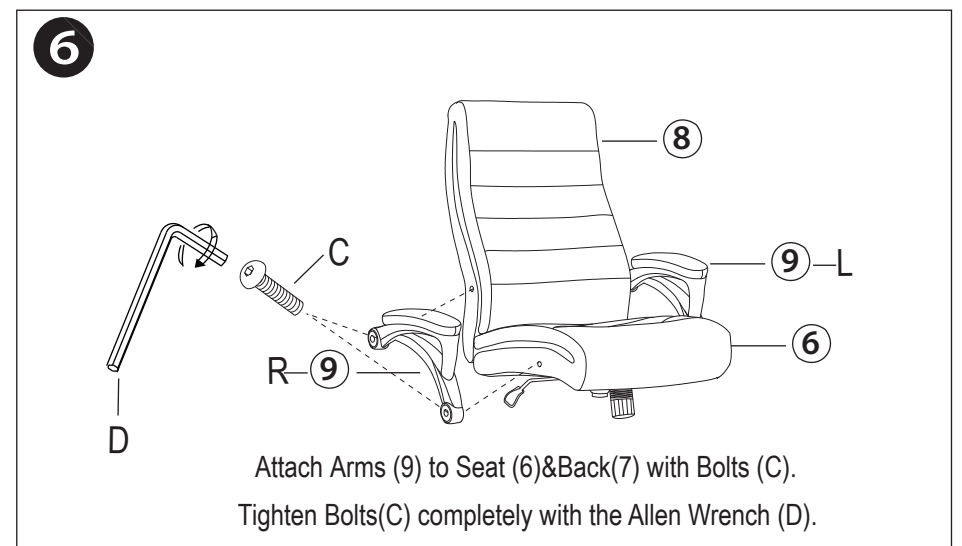
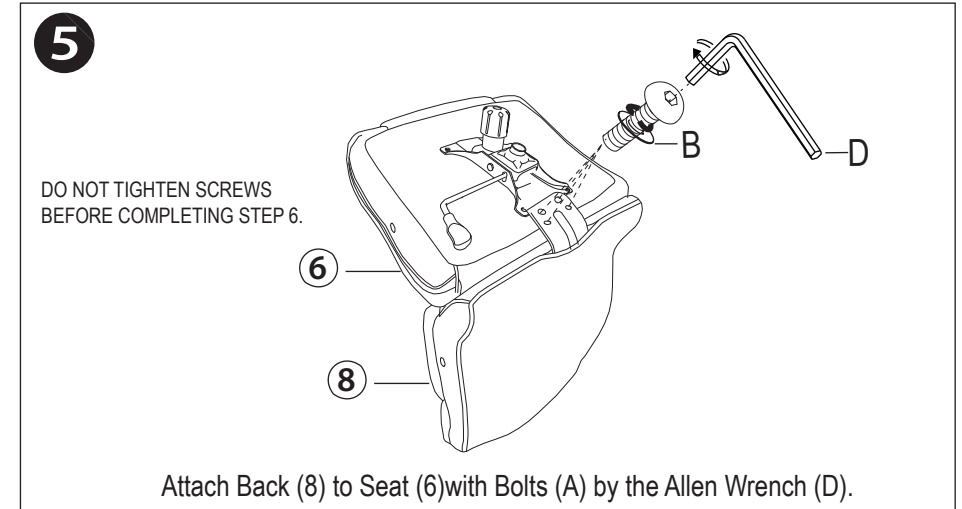

Installation Steps

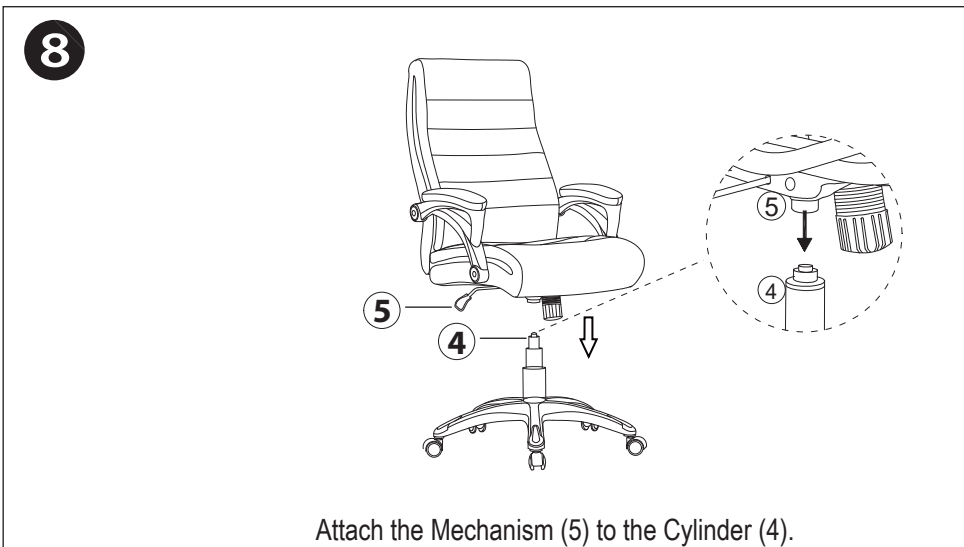
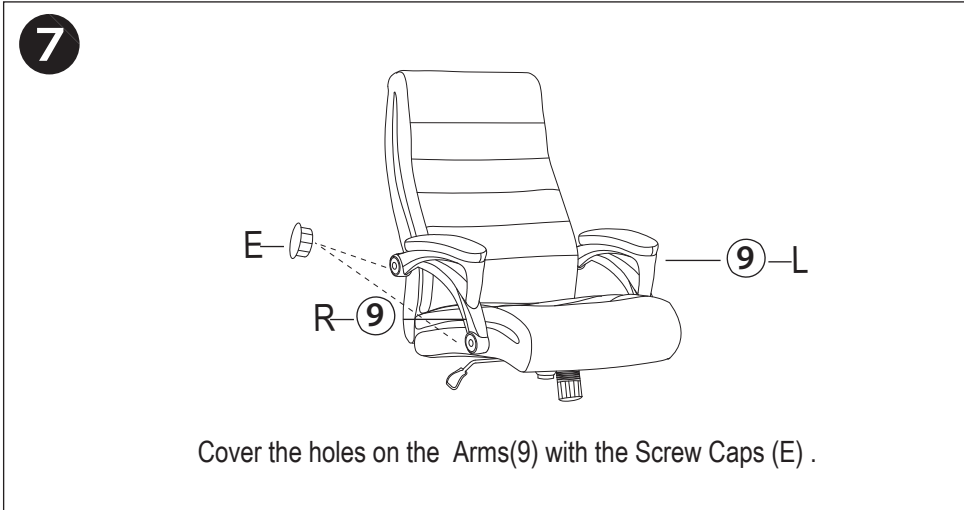

Installation Steps

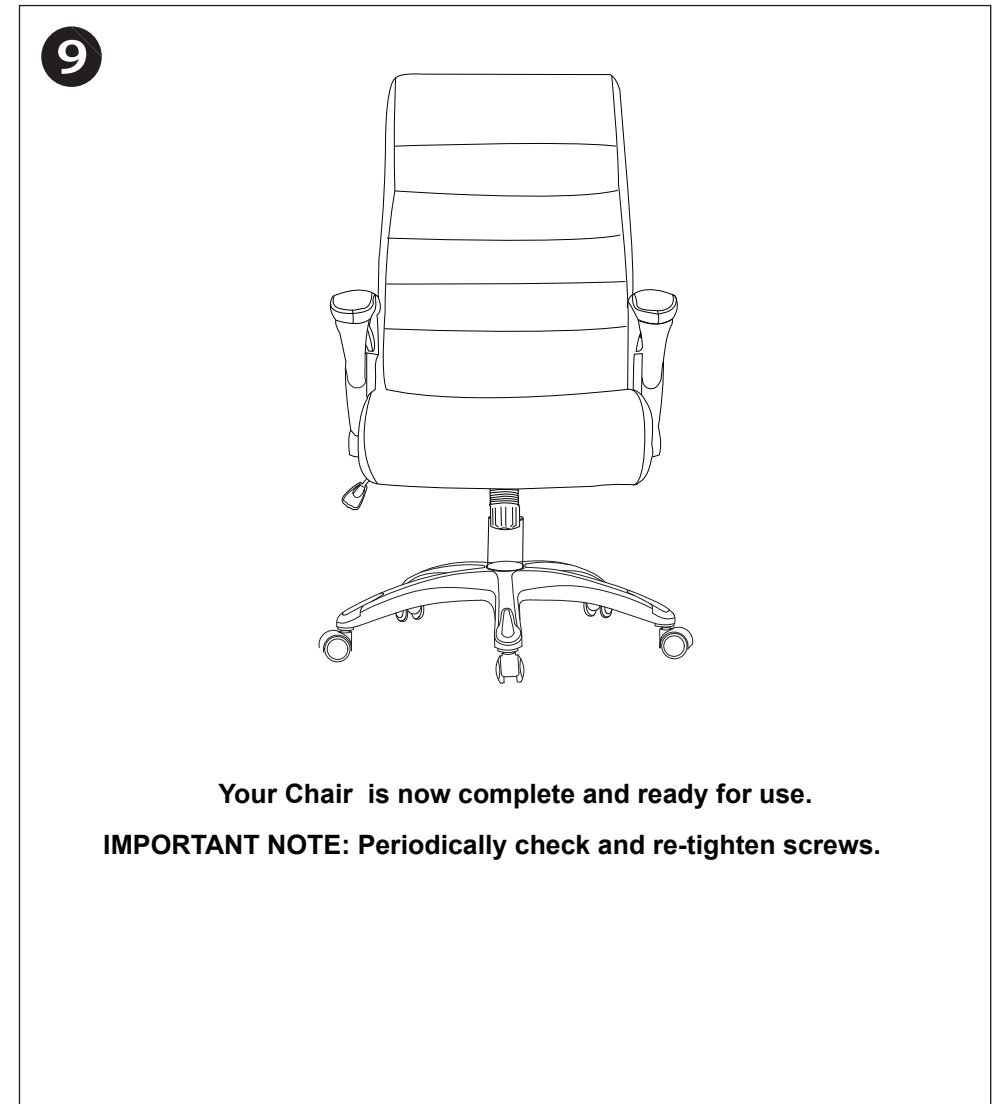

Care Instructions

- #Vacuum regularly
- #Wipe PU upholstery and non-upholstered parts with a clean damp cloth and mild soap. Wipe PU upholstery dry immediately with an absorbent dry cloth.
- #Spot clean with upholstery shampoo or dry powdered cleaner only. Test on a concealed area before proceeding. Apply proprietary cleaning products strictly according to instructions.
- #Do not saturate upholstery with water or other cleaning products.
- #Treat spills immediately with an absorbent cloth by blotting the spill.
- #Keep away and protect from direct sunlight and heat.
- #Do not use detergents, solvents or abrasive cleaners.
- # Keep away and protect from direct sunlight and heat.
- #Avoid contact with skin, in particular during high temperatures and humidity.
- #Clean, check and tighten parts regularly.

Functionality

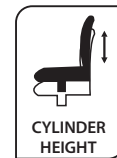

*Chair Height Adjustment

- To increase chair height pull lever upward while lifting body weight slightly off the seat.
- Release lever at desired height.

- To low chair height sit fully into the chair and pull lever upward.
- Release lever at desired height.



*Chair tension function

- Pull lever out to unlock & allow chair to tilt back & forth



*Adjustable Chair Tension Speed

- Turn continuously to adjust how quickly chair tilts back & forth.

