

8' Folding Conference Table Assembly Instructions

Questions? Call Cust. Svc. at 1-800-443-5117, M-F, 8:30-5 CT

Folding Frame

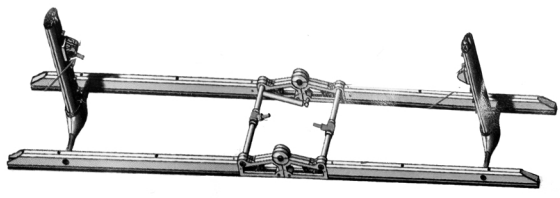

(2) Linkage Bars



(2) Legs



(4) Locking Casters



2) 4'x4' Table Tops

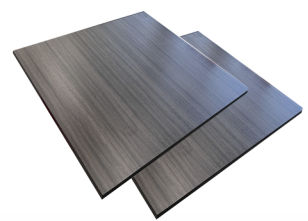

(4) Machine Bolts & Washers "A"

(12) Machine Bolts "B"



Wrenches



(2) Stoppers with Screws



Tips:

- 1) Assemble on carpet or cardboard for protection during assembly
- 2) Two people are recommended

Step 1) Attach the Linkage Bars to the Folding Frame

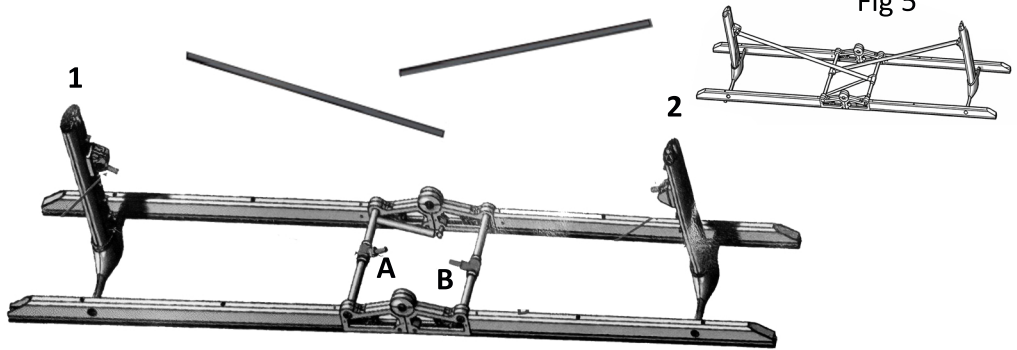

Attach one end of the linkage bar to the connector attached to the middle support beam of the table (Fig. 1-2). Then, using the two wrenches, unscrew the other connector from the outside support leg (Fig. 3). Screw the threaded end of the connector into the linkage bar (Fig. 4). Repeat process for the second linkage bar. For clarification, the linkage bars should attach like in Fig. 5, with B connecting to Side 1 and A connecting to Side 2.

8' Folding Conference Table Assembly Instructions

Questions? Call Cust. Svc. at 1-800-443-5117, M-F, 8:30-5 CT

Step 2) Attach the chrome legs to the frame using two "A" machine bolts with lock washers per leg.

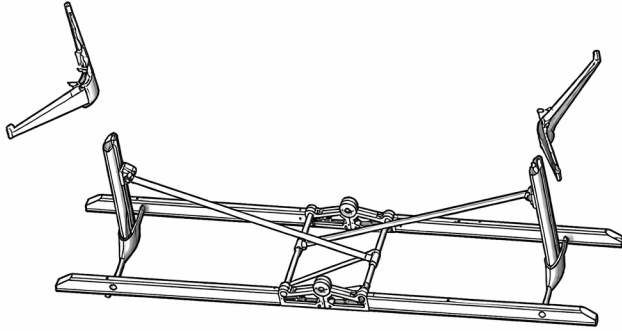

Step 3) Screw all four casters into the chrome legs.



Step 4) Install the stoppers to the undersides of the table tops using the wood screws provided. The stoppers should be installed 3" from the edges of the table tops, centered between the two rows of metal inserts. YOU ARE DRILLING YOUR OWN HOLES WITH THE SELF-THREADING SCREWS IN THIS STEP.

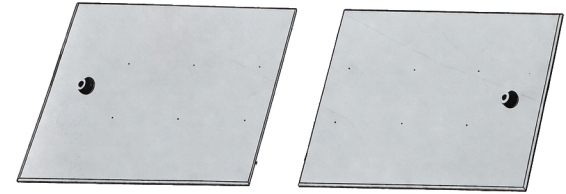

Step 5) Install table frame to table tops as shown. Use the 12, "B" Machine Bolts provided.

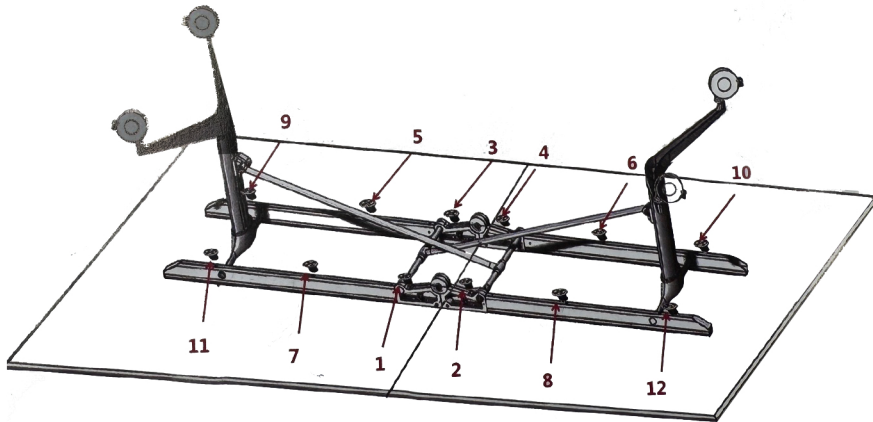

<----Check out our product video here!

