



Instructions for Set Up and Use

Chock Setup

1) Remove the chock and other parts from the packaging. Remove the bolt and nut holding the double arms to the wedge using the hex key provided for adjustments, and a 9/16" socket. *See Figure 1.*

2) Using the same nut and bolt, install the extra single arm onto that same wedge. The bolt should go through the end of the arm with the single hole. *See Figure 2.*

3) Set the chock between the tires and extend them out until the wedges touch the tires. *See Steps 3 - 5 in the standard instructions.*

4) Temporarily place the second clevis pin into the hole that aligns best between the double and single arms. Do not put the retainer clip into place on the pin yet.

5) Slide the chocks out from the tires. Remove the clevis pin, and slide the chock arms apart one hole, then replace the pin. Clip the pin into place.

6) Place the chock between the tires again. It should fit snugly between the tires, with the center arms not dropping all the way to the ground. Step down on the center arms to lock the chock into place. Pull up on the cable handle to remove the chock. *See Figure 3.*

7) Re-adjust the chock as necessary by moving the clevis pin to different holes, or by moving the end bolts that attach the arms to the wedges to a different hole.

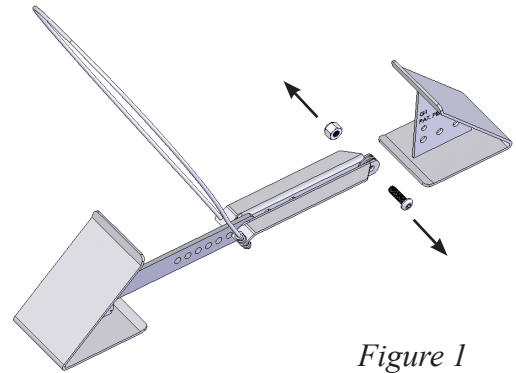

Figure 1

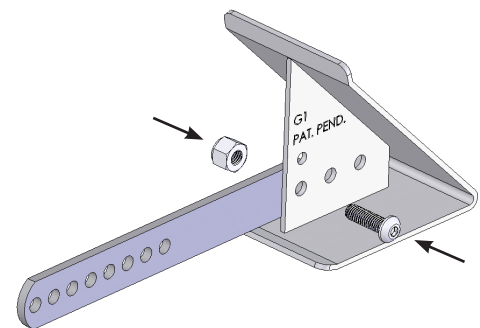

Figure 2

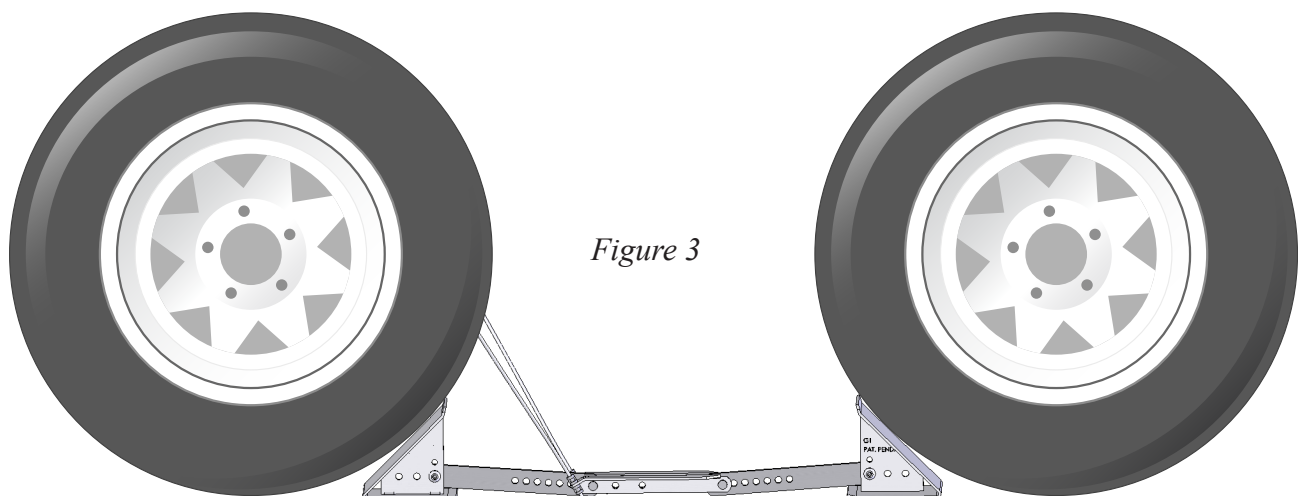

Figure 3

Continue on back →

WARNING

The Fastway® ONEstep™ Chock was designed to be used on level ground and gentle slopes. **Do not** use chock on grades that are excessive or unreasonably steep. Always remember to remove chock before attempting to tow trailer. Damage caused by driving over the wheel chock is not covered by warranty.

Limited One Year Warranty

Progress Mfg. Inc. warrants, to the original purchaser, this product against defects in materials and workmanship for a period of one year from date of purchase. This warranty does not cover damage due to normal wear and tear, misuse, neglect, abuse, or product finish. Progress Mfg. Inc. reserves the right to repair or replace the defective part(s) at their discretion. Replacement of product or refund constitutes the fulfillment of all liabilities of Progress Mfg. Inc. under this warranty. For questions about warranty coverage and warranty authorization, please call (800) 478-5578. If warranty repair or replacement is approved, send the entire product and proof of purchase, shipping pre-paid, to: Progress Mfg. Inc., 533 South 500 West, Provo, UT 84601

For a chock video demonstration visit us online at
www.fastwayrv.com

To see our full line of products visit
www.progressmfg.com

**533 South 500 West
Provo, UT 84601
1-800-478-5578**