

Parts Manual

Rotary Vacuum Pumps E1M40, E2M40, E1M80, E2M80 E1M40 ATEX, E2M40 ATEX E1M80 ATEX, E2M80 ATEX

Description	Item Number
E1M40, 240 V, 50 Hz, 1-phase	A344-01-960
E1M40, 220-240/380-415 V, 50 Hz, 3-phase	A344-01-935
E1M40, 208 V, 50 Hz/208-230 V, 60 Hz/460 V, 60 Hz, 3-phase	A344-02-982
E2M40, 240 V, 50 Hz, 1-phase	A364-01-960
E2M40, 220-240/380-415 V, 50 Hz, 3-phase	A364-01-935
E2M40, 208 V, 50 Hz/208-230 V, 60 Hz/460 V, 60 Hz, 3-phase	A364-02-982
E1M80, 220-240/380-415 V, 50 Hz, 3-phase	A345-01-935
E1M80, 208 V, 50 Hz/208-230 V, 60 Hz/460 V, 60 Hz, 3-phase	A345-02-982
E2M80, 220-240/380-415 V, 50 Hz, 3-phase	A365-01-935
E2M80, 208 V, 60 Hz/208-230 V, 60 Hz/460 V, 60 Hz, 3-phase	A365-02-982
E2M40S, 220-240/380-415 V, 50 Hz, 3-phase	A364-13-935
E2M40S, 208 V, 50 Hz/208-230 V, 60 Hz/460 V, 60 Hz, 3-phase	A364-13-982
E2M80S, 208 V, 50 Hz/208-230 V, 60 Hz/460 V, 60 Hz, 3-phase	A365-13-982
E1M40 ATEX 400 V, 50 Hz, IIB T4, 3-phase	A344-18-993
E2M40 ATEX 400 V, 50 Hz, IIB T4, 3-phase	A364-18-993
E1M80 ATEX 400 V, 50 Hz, IIB T4, 3-phase	A345-18-993
E2M80 ATEX 400 V, 50 Hz, IIB T4, 3-phase	A365-18-993
E2M40, 200/380 V, 50/60 Hz, 3-phase	A364-01-934
E2M40, 200/380 V, 50/60 Hz, 3-phase - fomblin prepared	A364-11-934
E2M80, 200/380 V, 50/60 Hz, 3-phase	A365-01-934
E2M80, 200/380 V, 50/60 Hz, 3-phase - fomblin prepared	A365-11-934



This page has been intentionally left blank.

Contents

Section	Page
1	Introduction 1
1.1	Scope of this manual 1
1.2	Parts list 1
2	Pump data tables 3
3	E1M40 major sub assemblies 5
A	E1M40 gas ballast valve sub-assembly 6
B	E1M40 adaptor sub-assembly 8
C	E1M40 oil distributor sub-assembly 10
D	E1M40 oil box sub-assembly 12
E	E1M40 HV stator sub-assembly 14
G	E1M40 motor plate sub-assembly 16
4	E2M40 major sub-assemblies 19
A	E2M40 gas ballast valve sub-assembly 20
B	E2M40 adaptor sub-assembly 22
C	E2M40 oil distributor sub-assembly 24
D	E2M40 oil box sub-assembly 26
E	E2M40 HV stator sub-assembly 28
F	E2M40 LV stator sub-assembly 30
G	E2M40 motor plate sub-assembly 32
5	E1M80 major sub-assemblies 35
A	E1M80 gas ballast valve sub-assembly 36
B	E1M80 adaptor sub-assembly 38
C	E1M80 oil distributor sub-assembly 40
D	E1M80 oil box sub-assembly 42
E	E1M80 HV stator sub-assembly 44
G	E1M80 motor plate sub-assembly 46
6	E2M80 major sub-assemblies 49
A	E2M80 gas ballast valve sub-assembly 50
B	E2M80 adaptor sub-assembly 52
C	E2M80 oil distributor sub-assembly 54
D	E2M80 oil box sub-assembly 56
E	E2M80 HV stator sub-assembly 58
F	E2M80 LV stator sub-assembly 60
G	E2M80 motor plate sub-assembly 62
7	E1M/E2M40/80 ATEX special items 65
8	Spares kits and single spare items 67
8.1	E1/E2M40 clean and overhaul kit - A34401131 67
8.2	E1M40 blade kit - A34401050 68
8.3	E2M40 blade kit - A36401050 68
8.4	E1M40 major service kit - A34401814 68
8.5	E2M40 major service kit - A36401814 69
8.6	E1/E2M80 clean and overhaul kit - A34501131 71
8.7	E1M80 blade kit - A34501050 71

8.8	E2M80 blade kit - A36501050	72
8.9	E1M80 major service kit - A34501814	72
8.10	E2M80 major service kit - A36501814	73
Appendix A1 E2M40 LV stator sub-assembly modification		75
Appendix B 1 Exhaust warning label		77

Illustrations

Figure		Page
1	E1M40 major sub-assemblies	5
2	(A) E1M40 gas ballast valve sub-assembly	6
3	(B) E1M40 adaptor sub-assembly	8
4	(C) E1M40 oil distributor sub-assembly	10
5	(D) E1M40 oil box sub-assembly	12
6	(E) E1M40 HV stator sub-assembly	14
7	(G) E1M40 motor plate sub-assembly	16
8	E2M40 major sub-assemblies	19
9	(A) E2M40 gas ballast valve sub-assembly	20
10	(B) E2M40 adaptor sub-assembly	22
11	(C) E2M40 oil distributor sub-assembly	24
12	(D) E2M40 oil box sub-assembly	26
13	(E) E2M40 HV stator sub-assembly	28
14	(F) E2M40 LV stator sub-assembly	30
15	(G) E2M40 motor plate sub-assembly	32
16	E1M80 major sub-assemblies	35
17	(A) E1M80 gas ballast valve sub-assembly	36
18	(B) E1M80 adaptor sub-assembly	38
19	(C) E1M80 oil distributor sub-assembly	40
20	(D) Oil box sub-assembly	42
21	(E) E1M80 HV stator sub-assembly	44
22	(G) E1M80 motor plate sub-assembly	46
23	E2M80 major sub-assemblies	49
24	(A) E2M80 gas ballast valve sub-assembly	50
25	(B) E2M80 adaptor sub-assembly	52
26	(C) E2M80 oil distributor sub-assembly	54
27	(D) Oil box sub-assembly	56
28	(E) E2M80 HV stator sub-assembly	58
29	(F) E2M80 LV stator sub-assembly	60
30	(G) E2M80 motor plate sub-assembly	62
31	E1M/E2M40/80 ATEX special items	65
A1	E2M40 LV stator sub-assembly (ECD 0322)	76
B1	Exhaust warning label (ECDs 50924 and 51060)	77

Tables

Table	Page
1	GA drawing list 1
1a	Pump item data table E1M40 3
1b	Pump item data table E2M40 3
1c	Pump item data table E1M80 3
1d	Pump item data table E2M80 3
1e	Pump item data table E1M40 ATEX 3
1f	Pump item data table E2M40 ATEX 3
1g	Pump item data table E1M80 ATEX 3
1h	Pump item data table E2M80 ATEX 4
2	E1M40 gas ballast valve sub-assembly items 7
3	E1M40 adaptor sub-assembly items 9
4	E1M40 oil distributor sub-assembly items 11
5	E1M40 oil box sub-assembly items 13
6	E1M40 HV stator sub-assembly items 15
7	E1M40 motor plate sub-assembly items 17
8	E2M40 gas ballast valve sub-assembly items 21
9	E2M40 adaptor sub-assembly items 23
10	E2M40 oil distributor sub-assembly items 25
11	E2M40 oil box sub-assembly items 27
12	E2M40 HV stator sub-assembly items 29
13	E2M40 LV stator sub-assembly items 31
13a	E2M40 LV rotor sub-assembly items 31
14	E2M40 motor plate sub-assembly items 33
15	E1M80 gas ballast valve sub-assembly items 37
16	E1M80 adaptor sub-assembly items 39
17	E1M80 oil distributor sub-assembly items 41
18	E1M80 oil box sub-assembly items 43
19	E1M80 HV stator sub-assembly items 45
20	E1M80 motor plate sub-assembly items 47
21	E2M80 gas ballast valve sub-assembly items 51
22	E2M80 adaptor sub-assembly items 53
23	E2M80 oil distributor sub-assembly items 55
24	E2M80 oil box sub-assembly items 57
25	E2M80 HV stator sub-assembly items 59
26	E2M80 LV stator sub-assembly items 61
27	E2M80 motor plate sub-assembly items 63
28	E1M/E2M40/80 ATEX special items 66
29	E1/E2M40 spares kits 67
30	E1/E2M80 spares kits 67
31	E1/E2M40 clean and overhaul kit items 67
32	E1M40 blade kit items 68
33	E2M40 blade kit items 68
34	E1M40 major service kit items 68
35	E2M40 major service kit items 69
36	E1/E2M80 clean and overhaul kit items 71
37	E1M80 blade kit items 71
38	E2M80 blade kit items 72
39	E1M80 major service kit items 72
40	E2M80 major service kit items 73
A1	E2M40 LV stator sub-assembly items (ECD 0322) 75

This page has been intentionally left blank.

1 Introduction

1.1 Scope of this manual

This manual provides information about the component parts of the Edwards E1M/E2M-40/80 Rotary Vacuum Pumps. Please note that the E1M40 and E1M80 variants are now obsolete. However, the information on these pumps is retained in this manual for reference and spares are still available.

Exploded views of the pumps are shown in [Section 2 to 7](#), together with their respective lists of parts. Spares kits and single spare items are listed in [Section 8](#). Appendices contain information about modifications.

1.2 Parts list

Each exploded view has an associated list of component parts. When you read [Table 2 to 40](#), take note of the following:

- "The 'Item' numbers in exploded views and tables correspond to numbers on Edwards 'General Arrangement' (GA) drawings. These identify major sub-assemblies which are illustrated ([Figure 1, 8, 16, and 23](#)) at the start of each pump section. These 'GA' drawings, their reference number and current issue status, are listed in [Table 1](#).
- "The notation A/R means 'as required'

The issues of the GA drawings used to generate this Parts Manual are listed in [Table 1](#) as follows:

Table 1 - GA drawing list

GA Number	Issue	Pump
A36401000	YF	E1M/E2M40
A36501000	YH	E1M/E2M80

This page has been intentionally left blank.

2 Pump data tables

Table 1a - Pump item data table E1M40 (obsolete)

Item No.	Motor code	Voltage (V)	Phase	Frequency (Hz)	Power (kW)	Enclosure rating
A34401935	A07111090	220-240	3	50	1.1	IP55
A34402982	A07112090	230/460	3	60	1.5	IP55
A34401960	A07111005	220/240	1	50	1.1	IP55 (Obsolete)

Table 1b - Pump item data table E2M40

Item No.	Motor code	Voltage (V)	Phase	Frequency (Hz)	Power (kW)	Enclosure rating
A36401935	A07111090	220-240 380-415	3	50	1.1	IP55
A36402982	A07112090	230/460	3	60	1.5	IP55
A36401960	A07111005	220/240	1	50	1.1	IP55 (Obsolete)
A36401934	A07112091	200/220	3	50/60	1.5	IP55

Table 1c - Pump item data table E1M80 (obsolete)

Item No.	Motor code	Voltage (V)	Phase	Frequency (Hz)	Power (kW)	Enclosure rating
A34501935	A07113090	220-240 380-420	3	50	2.2	IP55
A34502982	A07114090	230/460	3	60	3.0	IP55

Table 1d - Pump item data table E2M80

Item No.	Motor code	Voltage (V)	Phase	Frequency (Hz)	Power (kW)	Enclosure rating
A36501935	A07113090	220-240 380-420	3	50	2.2	IP55
A36502982	A07114090	230/460	3	60	3	IP55
A36501934	A07114091	180/220	3	50/60	3.0	IP55

Table 1e - Pump item data table E1M40 ATEX

Item No.	Motor assy	Voltage (V)	Phase	Frequency (Hz)	Power (kW)	ATEX rating	Enclosure rating
A34418993	A07128001	400	3	50	1.1	II B T4	IP55

Table 1f - Pump item data table E2M40 ATEX

Item No.	Motor assy	Voltage (V)	Phase	Frequency (Hz)	Power (kW)	ATEX rating	Enclosure rating
A36418993	A07128001	400	3	50	1.1	II B T4	IP55

Table 1g - Pump item data table E1M80 ATEX

Item No.	Motor assy	Voltage (V)	Phase	Frequency (Hz)	Power (kW)	ATEX rating	Enclosure rating
A34518993	A07129001	400	3	50	2.2	II B T4	IP55

Table 1h - Pump item data table E2M80 ATEX

Item No.	Motor assy	Voltage (V)	Phase	Frequency (Hz)	Power (kW)	ATEX rating	Enclosure rating
A36518993	A07129001	400	3	50	2.2	II B T4	IP55

3 E1M40 major sub assemblies

Figure 1 - E1M40 major sub-assemblies

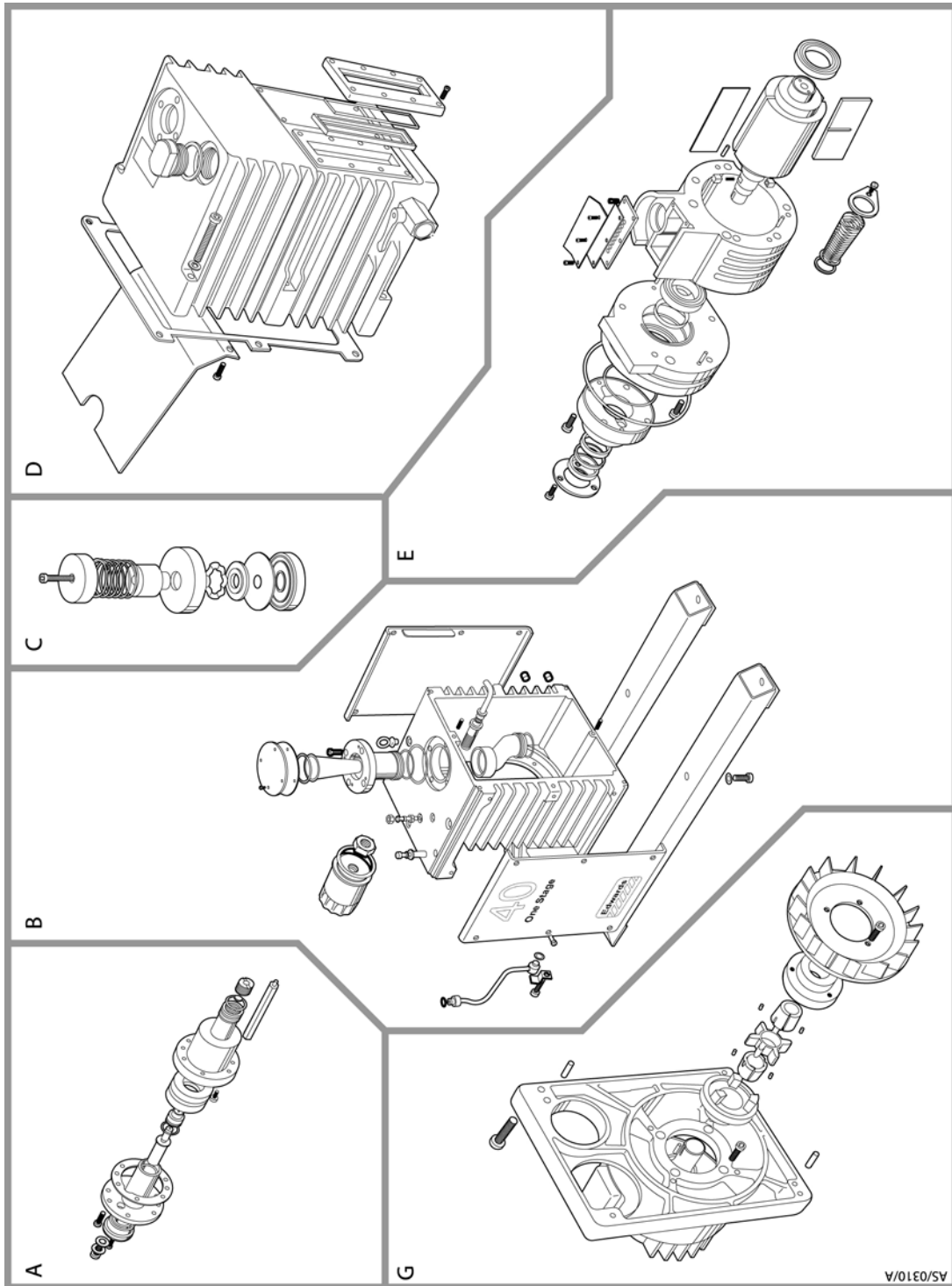

A E1M40 gas ballast valve sub-assembly

Figure 2 - (A) E1M40 gas ballast valve sub-assembly

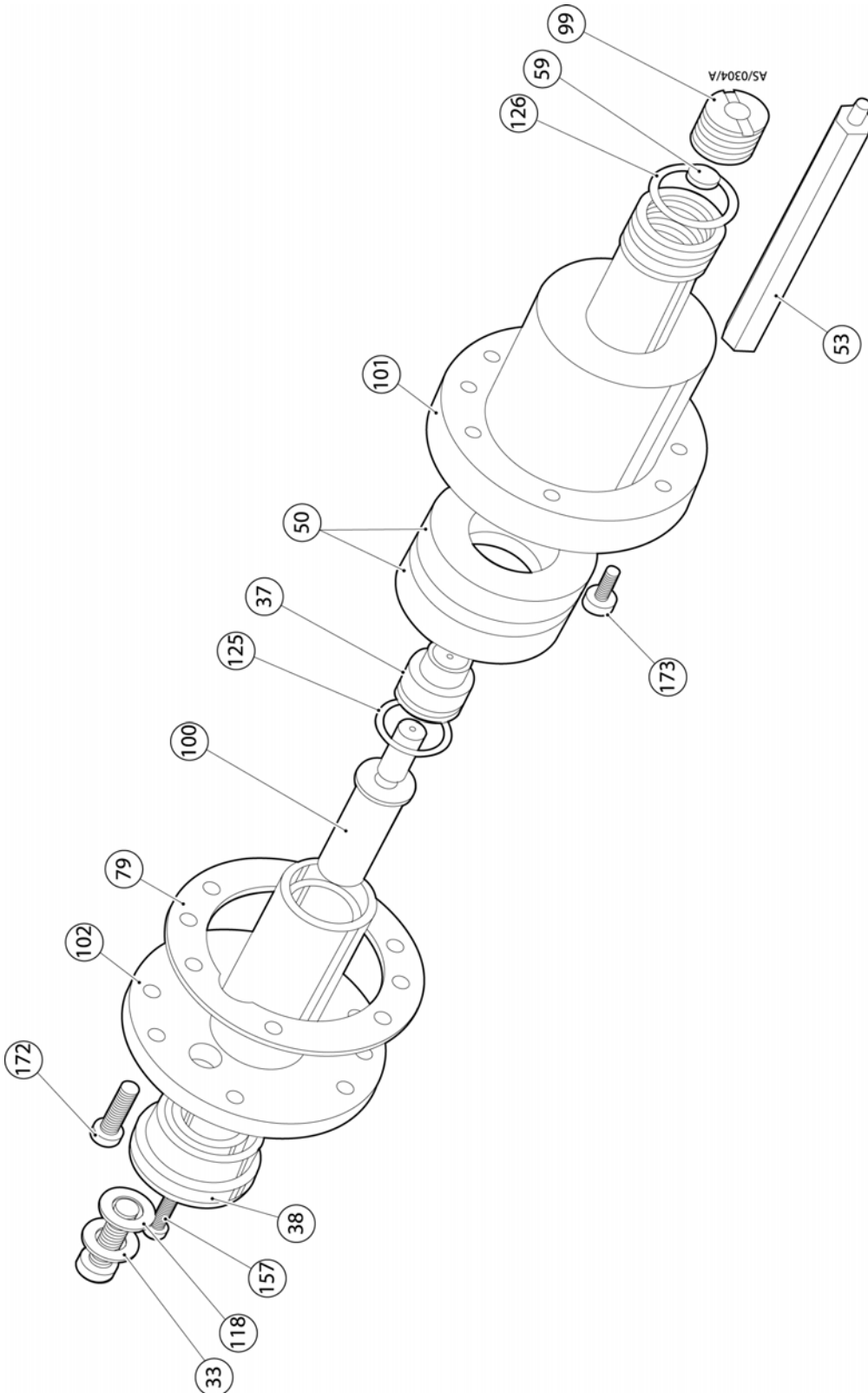
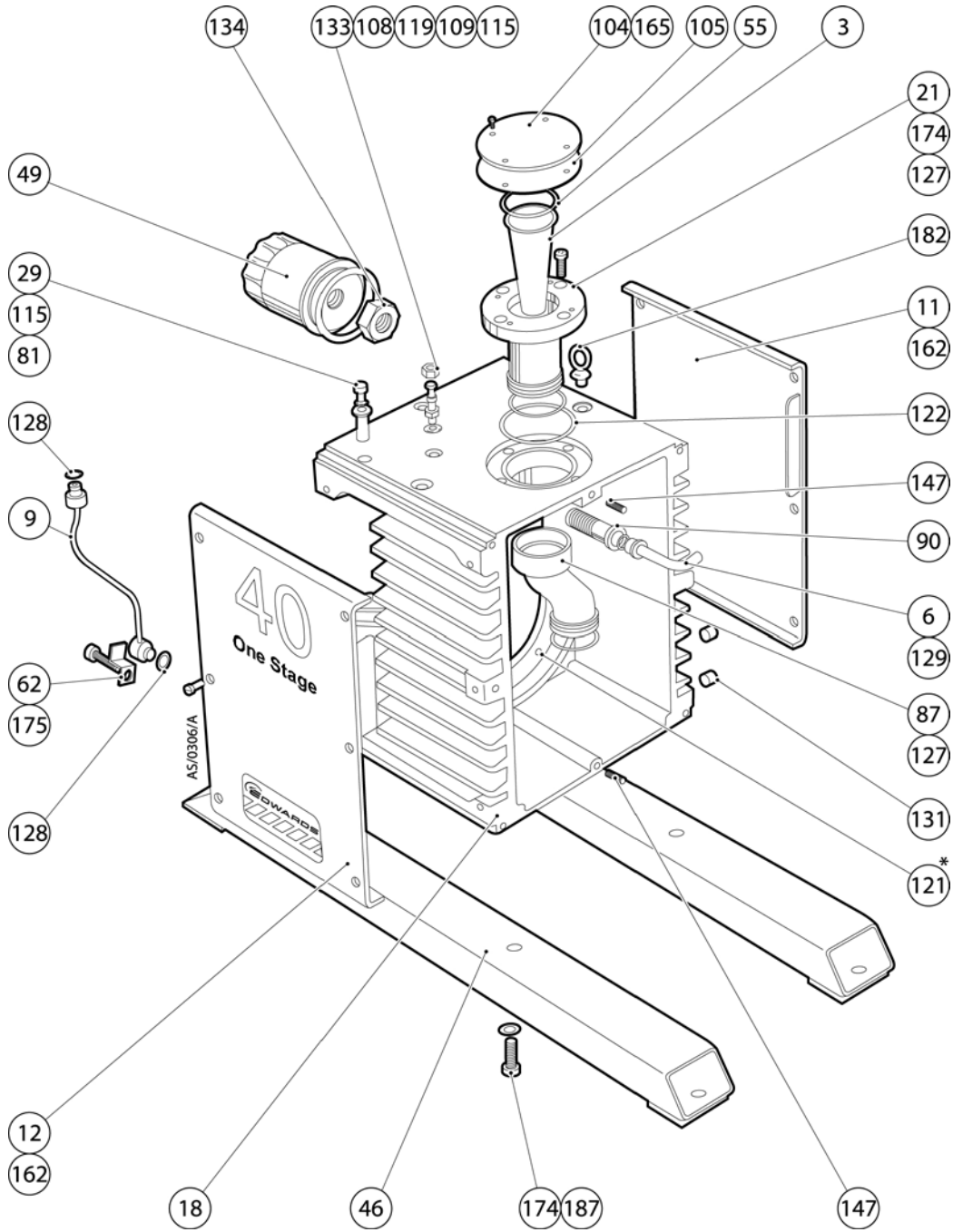

Table 2 - E1M40 gas ballast valve sub-assembly items

Item	Description	Code No.	Qty
33	Plug 1/4 inch BSP	A26002018	1
37	Ballast piston (no rubber seal)	A19201008	1
38	Ballast knob	A19201013	1
50	Ballast filter	A22305041	2
53	Support pillar	A22404006	2
59	Ballast valve	A25904601	1
79	Body gasket	A27159428	1
99	Ballast plug	A36601034	1
100	Ballast spindle	A36601036	1
101	Ballast valve body	A34401008	1
102	Ballast valve bearing	A34401009	1
118	Dowty seal- 1/4 inch BSP	H02104002	1
125	O-ring 7/16 inch i/d x 3/32 inch sect.	H02125011	1
126	O-ring 3/4 inch i/d x 1/8 inch sect.	H02126020	1
157	C'sk hd. scr. M4 x 16 lg.	218032290	1
172	Soc. hd. cap scr. M6 x 16 lg.	218091370	6
173	Soc. hd. cap scr. M6 x 20 lg.	218091371	2

B E1M40 adaptor sub-assembly

Figure 3 - (B) E1M40 adaptor sub-assembly



* Used on item 15 (ref. Figure 6)

Table 3 - E1M40 adaptor sub-assembly items

Item	Description	Code No.	Qty
3	Filter assy. (inlet)	A22305035	1
6	Tube assy. (oil return)	A27879001	1
9	Tube assy. (oil pressure)	A27879009	1
11	Side pane (right-hand)	A34401012	1
12	Side panel (left-hand)	A34401011	1
18	Adaptor	A36401032	1
21	Inlet flange	A36401024	1
29	Plug - 1/8 inch BSP	A01403074	1
46	Base runner	A20499019	2
49	Filter	A22304041	1
55	Circlip	A22426004	1
62	Clamp (oil pressure line)	A25970036	1
81	1/8 inch BSP socket	A27911003	1
87	Inlet connection	A36501009	1
90	Filter outlet	A36501013	1
104	Protective cover	B21023019	1
105	Dust cover	B21024001	1
108	Blind tailpiece	C11001062	1
109	Adaptor - sc5mm x 1/8 inch BSP	C11001180	1
115	Dowty seal - 1/8 inch BSP	H02104001	2
119	O-ring 5.6 mm i/d x 2.4 mm sect.	H02120027	1
121	O-ring 12.42 mm i/d x 1.78 mm sect. Fluoro	H02124119	1
122	O-ring 61.6 mm i/d x 2.4 mm sect.	H02120057	1
127	O-ring 17/8 inch i/d x 3/16 inch sect.	H02125044	2
128	O-ring 3/16 inch i/d x 3/32 inch sect.	H02125115	2
129	O-ring 5/16 inch i/d x 3/32 inch sect.	H02125116	1
131	1/4 inch BSP hollow taper pressure plug	H03517003	2
133	Union nut - 3/8 inch BSP	M03400008	1
134	Locknut - 3/4 inch x 16UNF ms. ni. pl.	216814314	1
147	Spring pin - ø8 x 24 1g.	212170186	2
162	Pan hd. scr. ss M5 x 10	218221328	12
165	Hex hd. scr. M8 x 12 1g.	218072409	2
174	Soc. hd. cap scr. M8 x 20 lg.	218091411	8
175	Soc. hd. cap scr. M8 x 25 1g.	218091412	1
182	Eyebolt - M12	218790005	2
187	Plain washer	218980210	4

C E1M40 oil distributor sub-assembly

Figure 4 - (C) E1M40 oil distributor sub-assembly

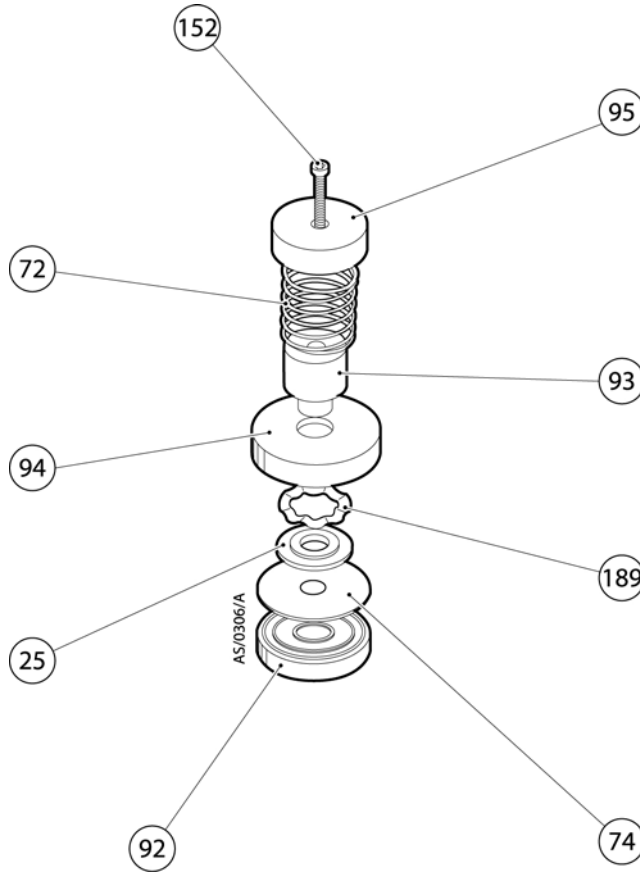

Table 4 - E1M40 oil distributor sub-assembly items

Item	Description	Code No.	Qty
25	Distributor weight	A34301037	1
72	Spring	A27102013	1
74	Rubber seal	A27159415	1
92	Distributor body	A36501015	1
93	Distributor sleeve	A36401019	1
94	Cap	A36401028	1
95	Spacer	A36401029	1
152	Hex hd. scr. ms. ni. pl. M5 x 60 lg.	218002339	1
189	Waved washer	218990201	1

D E1M40 oil box sub-assembly

Figure 5 - (D) E1M40 oil box sub-assembly

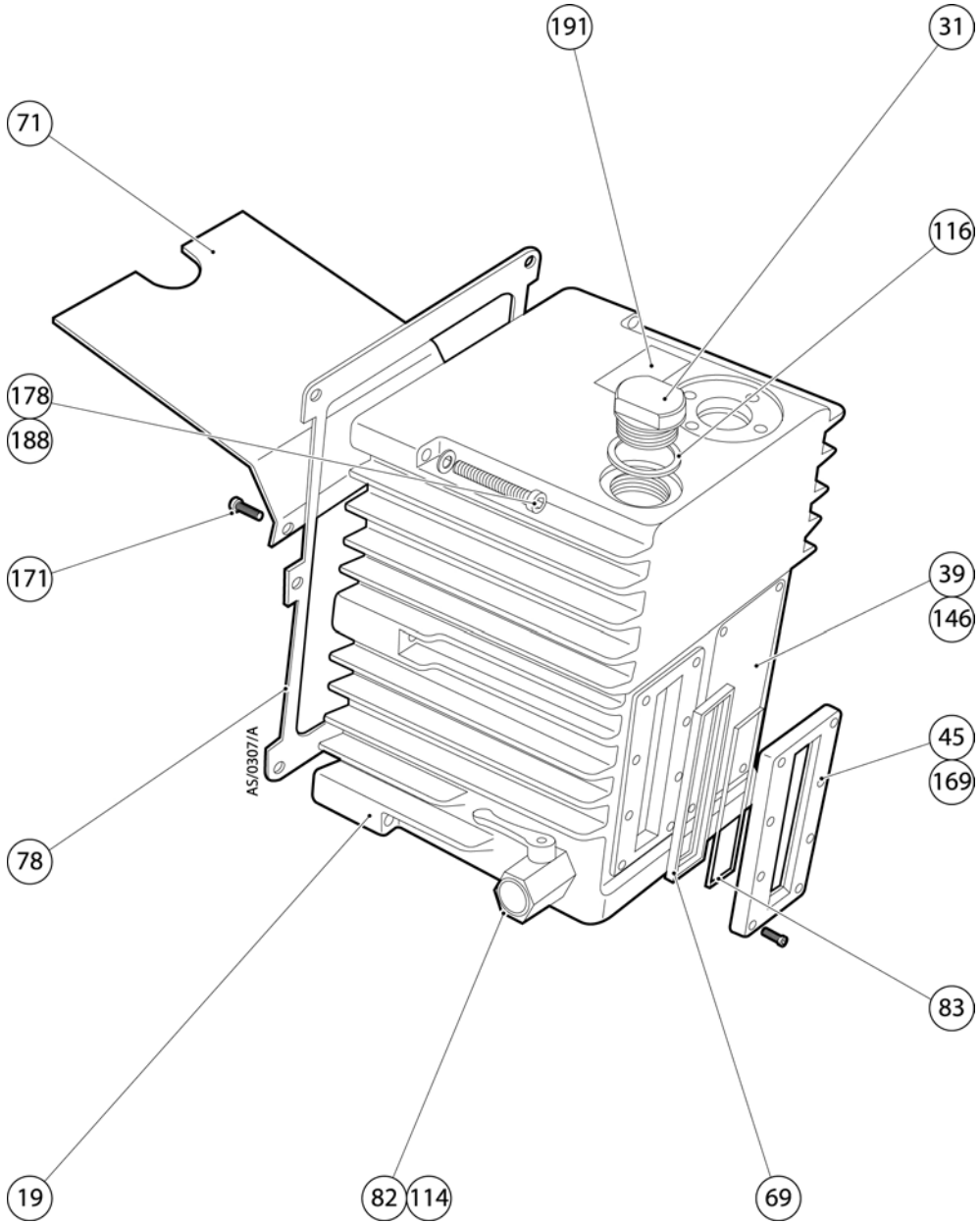

Table 5 - E1M40 oil box sub-assembly items

Item	Description	Code No.	Qty
19	Oil box	A36401038	1
31	Filler plug - 1 inch BSP	A26002022	1
39	Label	A20001063	1
45	Sight glass bezel	A20416002	1
69	Sight glass seal	A26501012	1
71	Spray baffle	A25976033	1
78	Oil box gasket	A27159629	1
82	Ball valve -1/2 inch BSP	A28702003	1
83	Sight glass	A29201006	1
114	Redcap -1/2 inch BSP	H01503333	1
116	Dowty seal - 1 inch BSP	H02104008	1
146	Rivet	211430301	4
169	Soc. hd. cap scr. M5 x 16 lg.	218091330	8
171	Soc. hd. cap scr. M6 x 12 lg.	218091369	3
178	Soc. hd. cap scr. M8 x 70 lg.	218091416	6
188	Rect. sect. s/coil spring washer M8	218985810	6
191	Hazard warning label	A20001084	1

E E1M40 HV stator sub-assembly

Figure 6 - (E) E1M40 HV stator sub-assembly

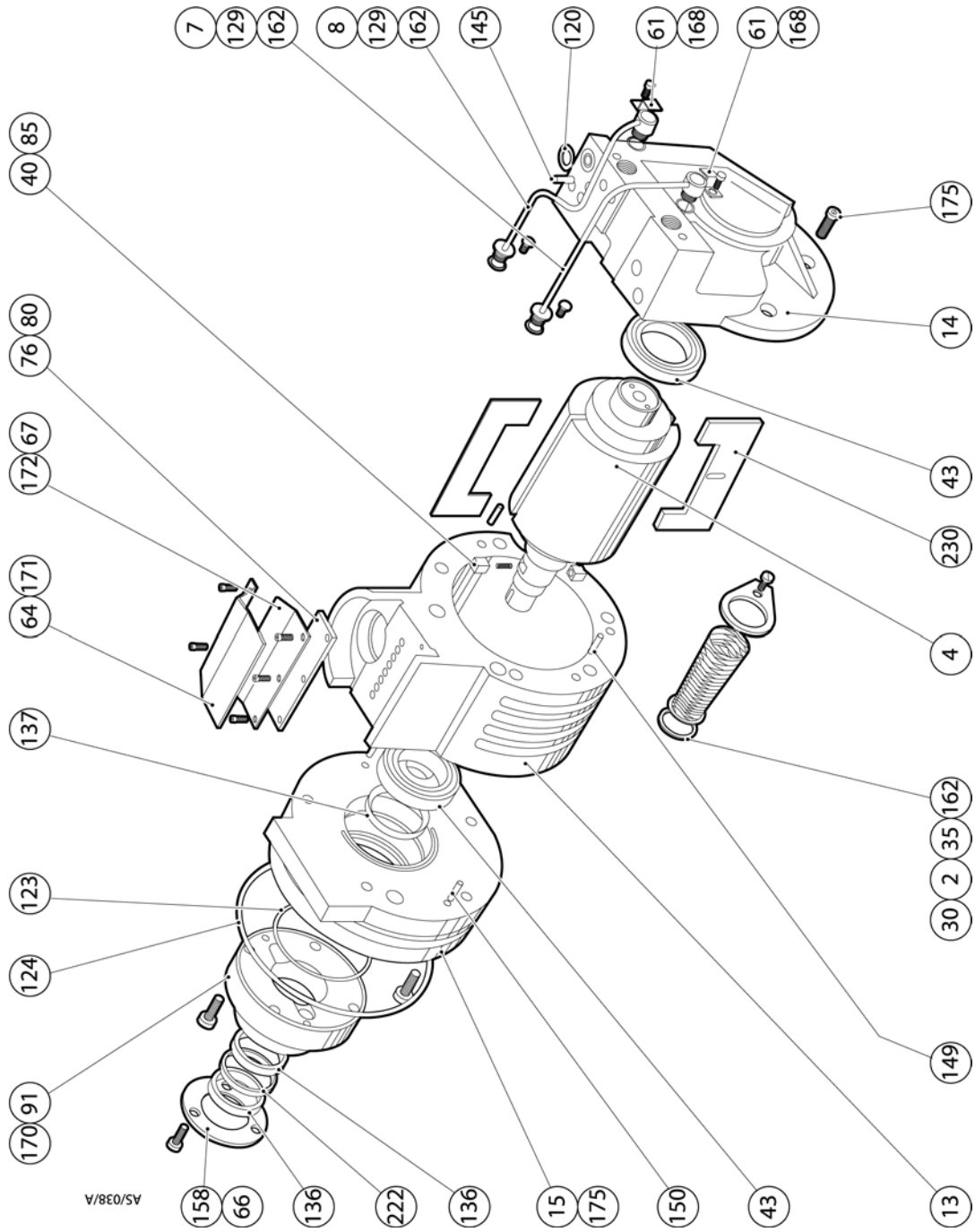

Table 6 - E1M40 HV stator sub-assembly items

Item	Description	Code No	Qty
2	Filter assy (oil)	A22305050	1
4	Rotor - High Vac. (Spare)	A26401770	1
7	Tube assy. (ballast)	A34401007	1
8	Tube assy. (oil delivery)	A34401006	1
13	High Vac. stator (Spare)	A34401702	1
14	Rear cover	A34401005	1
15	Front bearing	A36401001	1
30	Filter seal	A01403030	1
35	Clamp plate	A36401031	1
40	Oil pump blade	A20402418	2
43	Roller bearing	A20404011	2
61	Clamp (oil delivery line)	A25970035	2
64	Exhaust baffle	A25970031	1
66	Seal retainer	A25971002	1
67	Exhaust valve plate	A25976006	1
76	Exhaust valve rubber	A27159514	1
80	Exhaust valve spacer	A27804004	3
85	Spring	A27102024	1
91	Oil pump housing	A36501014	1
120	O-ring 9.6 mm i/d x 2.4 mm sect.	H02120031	1
123	O-ring 64.5 mm i/d x 3.0 mm sect.	H02120082	1
124	O-ring 139.5 mm i/d x 3.0 mm sect.	H02120097	1
129	O-ring 5/16 inch i/d x 3/32 inch sect.	H02125116	4
136	Oil seal	H02109094	2
137	Oil seal	H02109064	1
145	Spring pin \varnothing 1/4 inch x 1/2 inch lg.	211174099	2
149	Taper pin \varnothing 8 x 36 lg.	212192021	2
150	Taper pin \varnothing 8 x 60 lg.	212192026	3
158	C'sk. hd. scr. M5 x 10 lg.	218032328	3
162	Pan hd. scr. ssM5 x 10 lg.	218221328	2
168	Soc hd. cap scr. M5 x 10 lg.	218091328	4
170	Soc hd. cap scr. M5 x 25 lg.	218091332	2
171	Soc hd. cap scr. M6 x 12 lg.	218091369	3
172	Soc hd. cap scr. M6 x 16 lg.	218091370	10
175	Soc hd. cap scr. M8 x 25 lg.	218091412	1
222	Aluminium spacer	A26426001	1
230	High Vac. blade	A20402161	2

G E1M40 motor plate sub-assembly

Figure 7 - (G) E1M40 motor plate sub-assembly

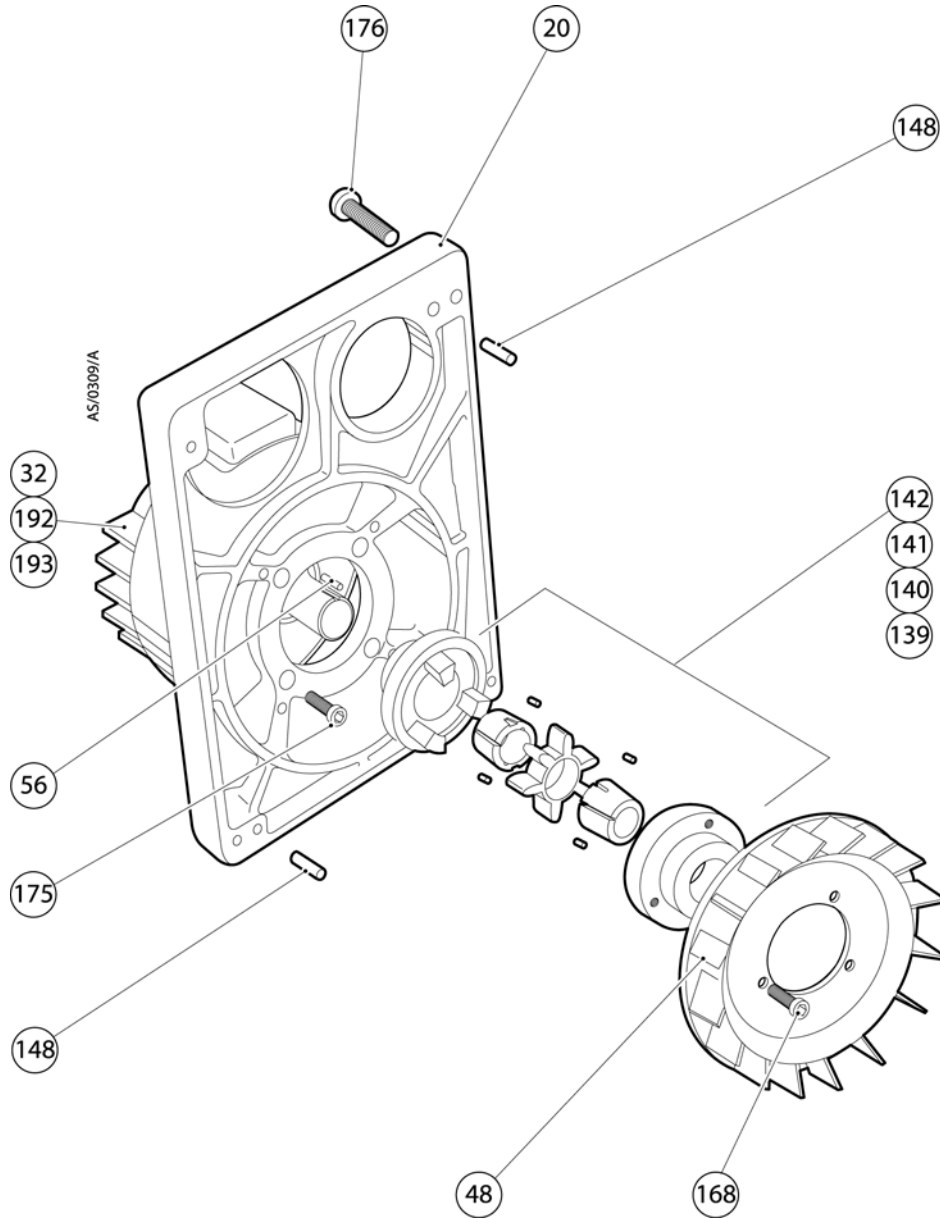

Table 7 - E1M40 motor plate sub-assembly items

Item	Description	Code No.	Qty
20	Motor mounting	A36401008	1
32	E1M40 Motor - see Table 1a	-----	1
48	Fan	A22301003	1
56	Key - 8 x 7 x 20 lg.	A24301008	1
139	Flexible component	A21071033	1
140	Coupling flange	A21071037	1
141	Coupling flange	A21071038	1
142	Taper lock brush	A21071039	2
148	Parallel dowel - ø8 x 24 lg.	212181076	2
168	Soc. hd. cap scr. M5 x 10 lg.	218091328	3
175	Soc. hd. cap scr. M8 x 25 lg.	218091412	4
176	Soc. hd. cap scr. M8 x 40 lg.	218091415	4
192	Electrical warning label	E20001063	1
193	Direction label	A20001085	1

This page has been intentionally left blank.

4 E2M40 major sub-assemblies

Figure 8 - E2M40 major sub-assemblies

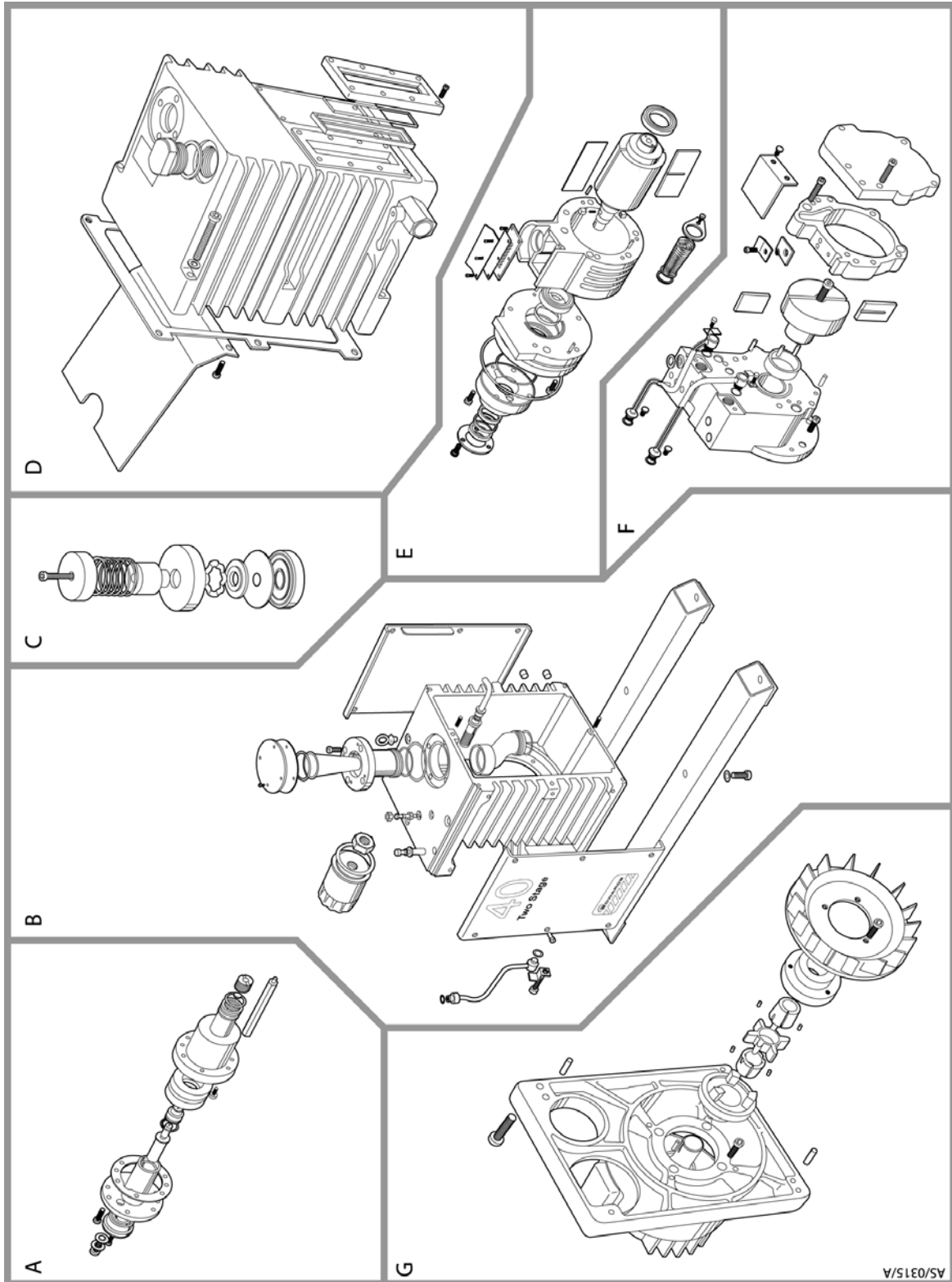

A E2M40 gas ballast valve sub-assembly

Figure 9 - (A) E2M40 gas ballast valve sub-assembly

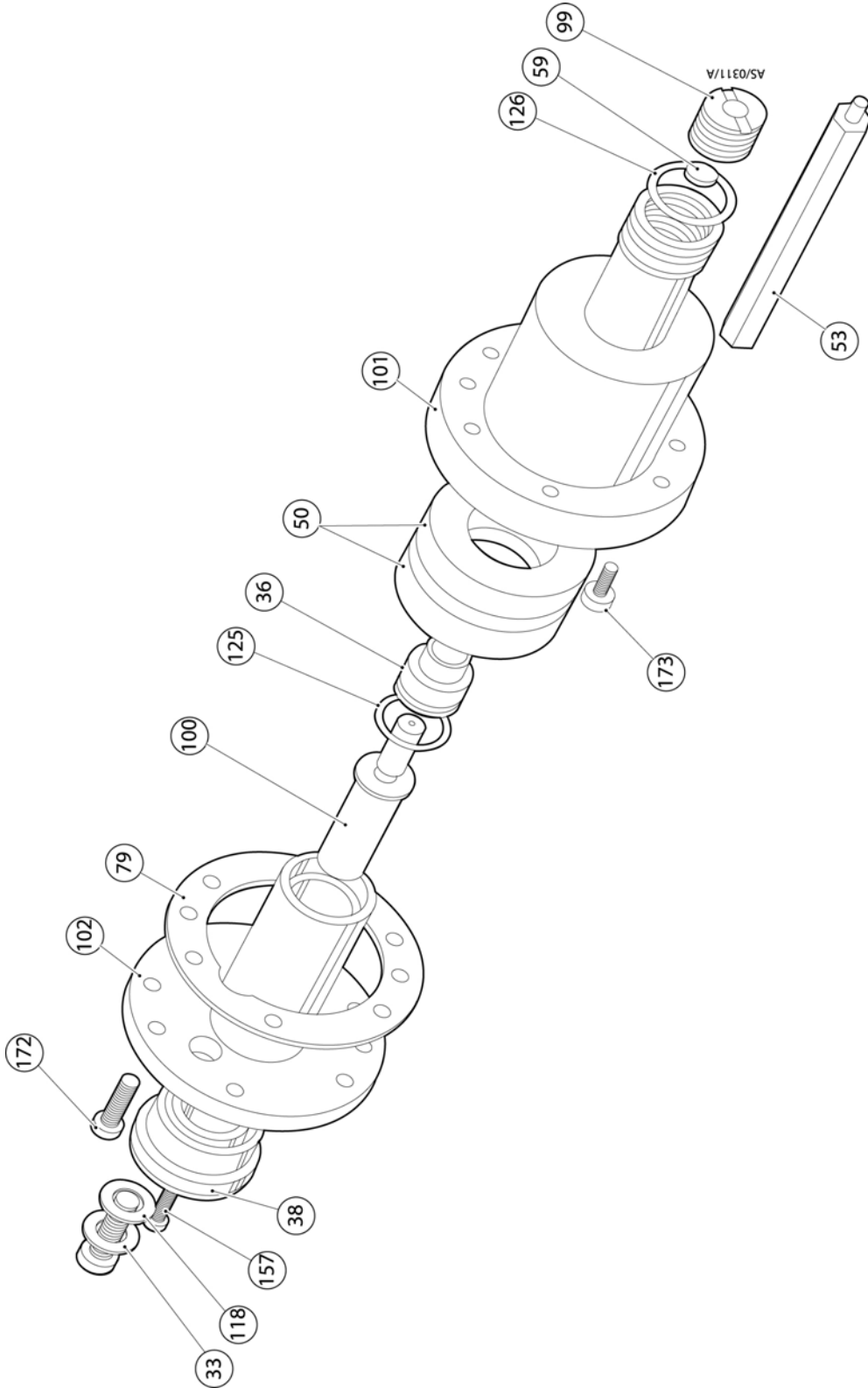

Table 8 - E2M40 gas ballast valve sub-assembly items

Item	Description	Code No.	Qty
33	Plug 1/4 inch BSP	A26002018	1
36	Ballast piston	A19201007	1
38	Ballast knob	A19201013	1
50	Ballast filter	A22305041	2
53	Support pillar	A22404006	2
59	Ballast valve	A25904601	1
79	Body gasket	A27159428	1
99	Ballast plug	A36601034	1
100	Ballast spindle	A36601036	1
101	Ballast valve body	A34401008	1
102	Ballast valve bearing	A34401009	1
118	Dowty seal - 1/4 inch BSP	H02104002	1
125	O-ring 7/16 inch i/d x 3 /32 inch sect.	H02125011	1
126	O-ring 3/4 inch i/d x 3/16 inch sect.	H02126020	1
157	C'sk hd. scr. M4 x 16 lg.	218032290	1
172	Soc. hd. cap scr. M6 x 16 lg.	218091370	6
173	Soc. hd. cap scr. M6 x 20 lg.	218091371	2

B E2M40 adaptor sub-assembly

Figure 10 - (B) E2M40 adaptor sub-assembly

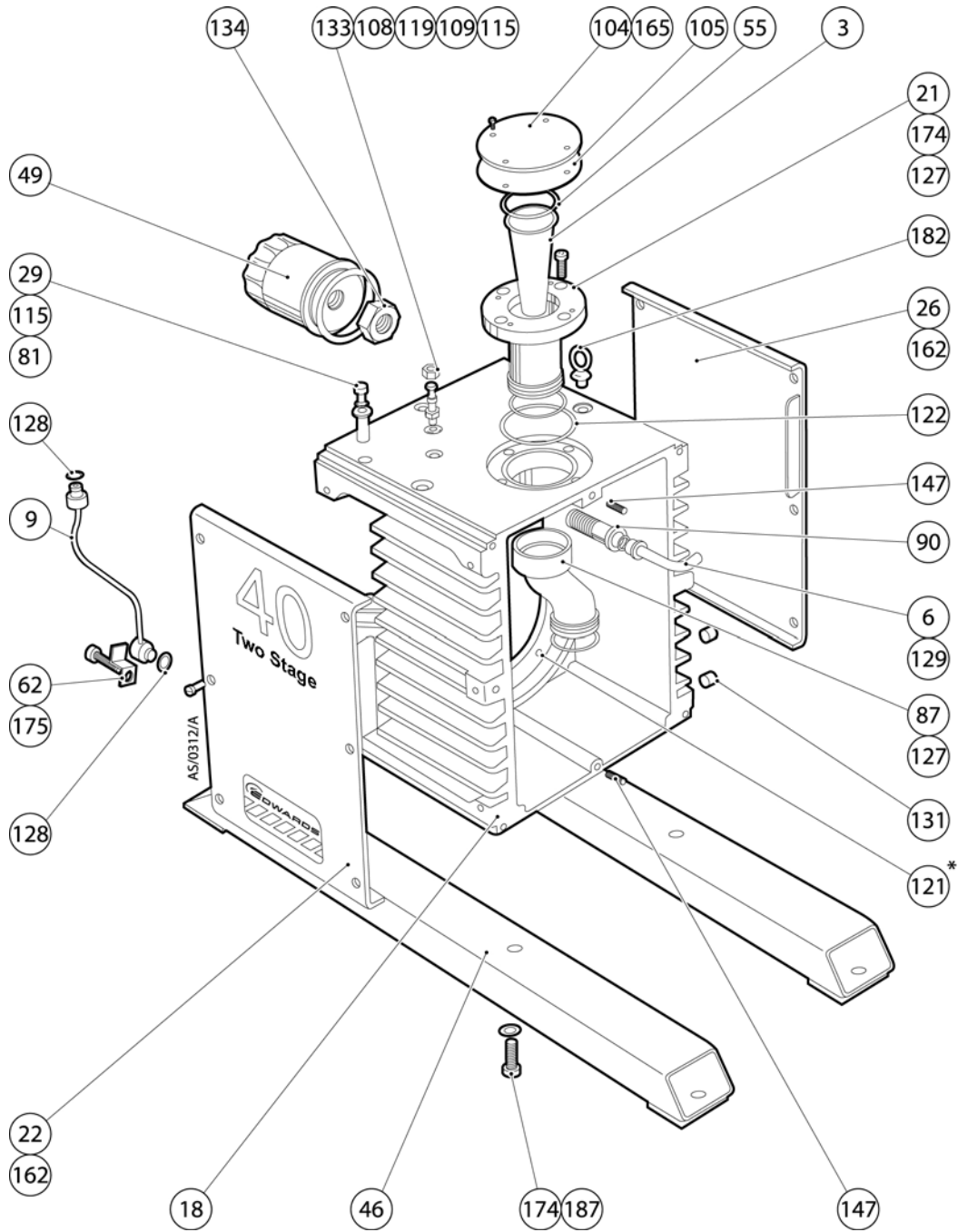

Table 9 - E2M40 adaptor sub-assembly items

Item	Description	Code No.	Qty
3	Filter assy. (inlet)	A22305035	1
6	Tube assy. (oil return)	A27879001	1
9	Tube assy. (oil pressure)	A27879009	1
18	Adaptor	A36401032	1
21	Inlet flange	A36401024	1
22	Side panel (left-hand)	A36401015	1
26	Side panel (right-hand)	A36401016	1
29	Plug - 1/8 inch BSP	A01403074	1
46	Base runner	A20499019	2
49	Filter	A22304041	1
55	Circlip	A22426004	1
62	Clamp (oil pressure line)	A25970036	1
81	1/8 inch BSP socket	A27911003	1
87	Inlet connection	A36501009	1
90	Filter outlet	A36501013	1
104	Protective cover	B21023019	1
105	Dust cover	B21024001	1
108	Blind tailpiece	C11001062	1
109	Adaptor - sc 5 mm x 1/8 inch BSP	C11001180	1
115	Dowty seal - 1/8 inch BSP	H02104001	2
119	O-ring 5.6 mm i/d x 2.4 mm sect.	H02120027	1
121	O-ring 12.42 mm i/d x 1.78 mm sect. Fluoro	H02124119	1
122	O-ring 61.6 mm i/d x 2.4 mm sect.	H02120057	1
127	O-ring 17/8 inch i/d x 3.16 inch sect.	H02125044	2
128	O-ring 3/16 inch i/d x 3/32 inch sect.	H02125115	2
129	O-ring 5/16 inch i/d x 3/32 inch sect.	H02125116	1
131	1/4 inch BSP hollow taper pressure plug	H03517003	2
133	Union nut - 3/8 inch BSP	M03400008	1
134	Locknut - 3/4 inch x 16UNF ms. ni. pl.	216814314	1
147	Spring pin - \varnothing 8 x 24 lg.	212170186	2
162	Pan hd. scr. ss M5 x 10	218221328	12
165	Hex hd. scr. M8 x 12 lg.	218072409	2
174	Sac. hd. cap scr. M8 x 20 lg.	218091411	8
175	Soc. hd. cap scr. M8 x 25 lg.	218091412	1
182	Eyebolt - M12	218790005	2
187	Plain washer	218980210	4

C E2M40 oil distributor sub-assembly

Figure 11 - (C) E2M40 oil distributor sub-assembly

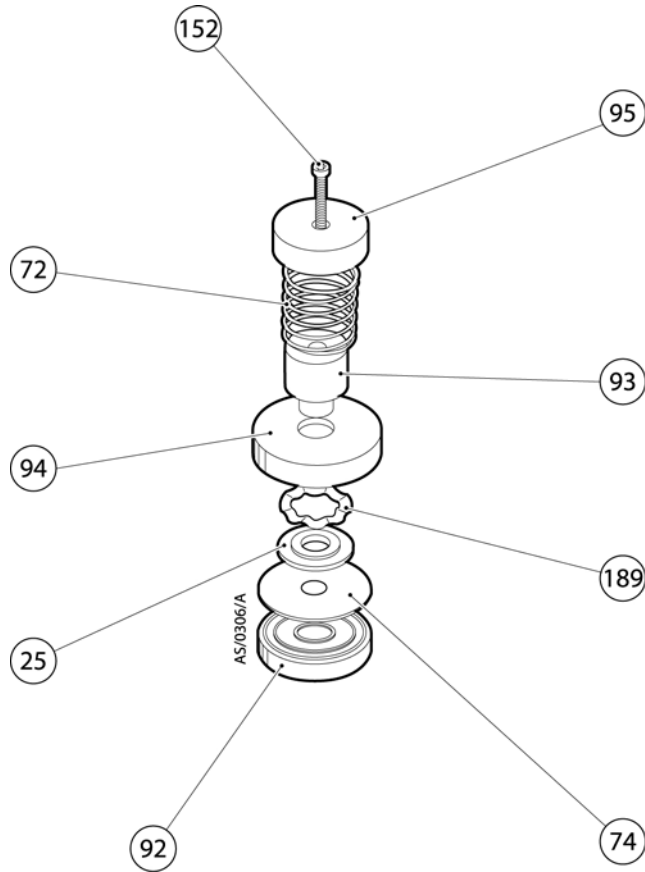

Table 10 - E2M40 oil distributor sub-assembly items

Item	Description	Code No.	Qty
25	Distributor weight	A34301037	1
72	Spring	A37102013	1
74	Rubber seal	A27159415	1
92	Distributor body	A36501015	1
93	Distributor sleeve	A36401019	1
94	Cap	A36401028	1
95	Spacer	A36401029	1
152	Hex hd. scr. ms. ni. pl. M5 x 60 lg.	218002339	1
189	Waved washer	218990201	1

D E2M40 oil box sub-assembly

Figure 12 - (D) E2M40 oil box sub-assembly

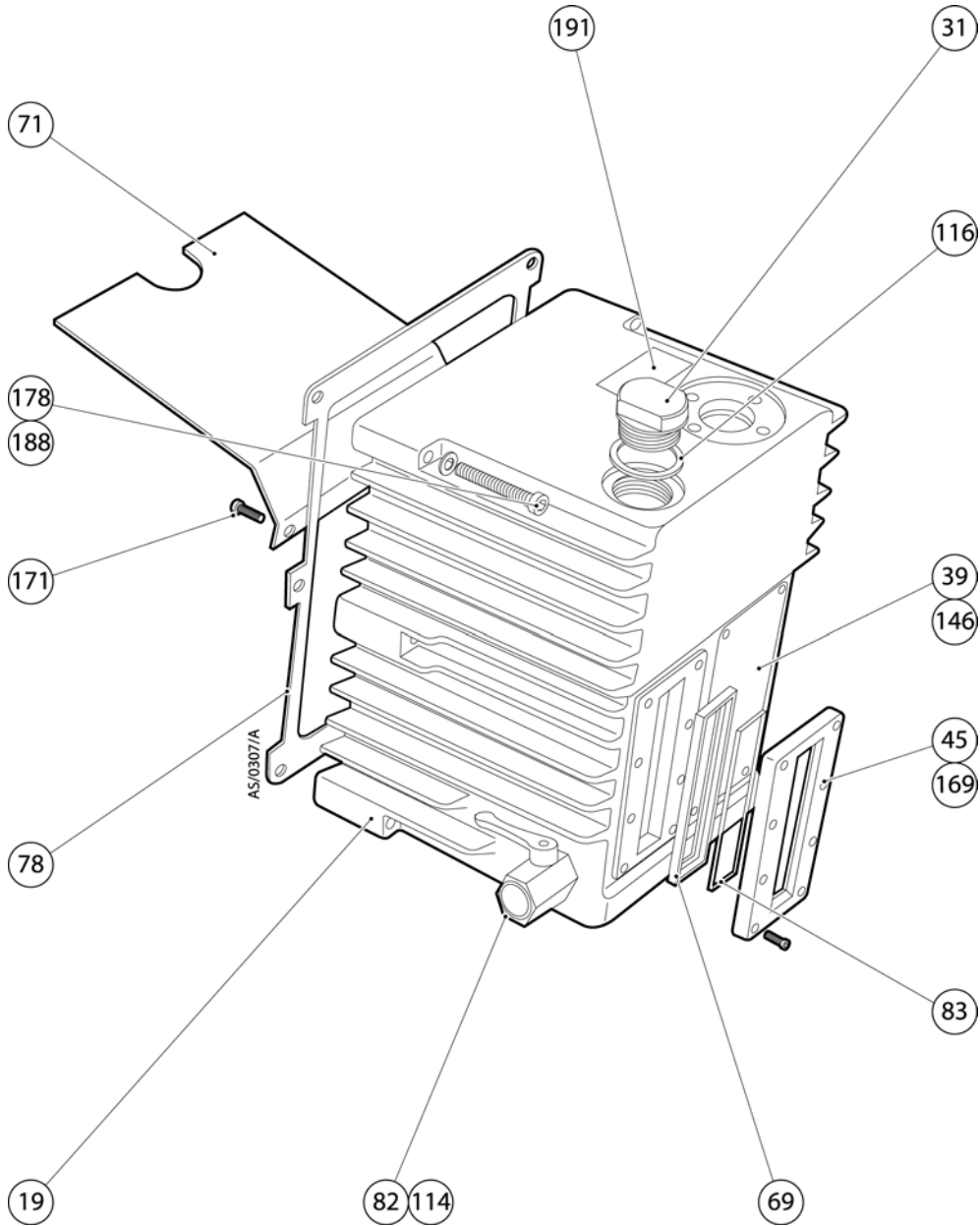

Table 11 - E2M40 oil box sub-assembly items

Item	Description	Code No.	Qty
19	Oil box	A36401038	1
31	Filler plug -1 inch BSP	A26002022	1
39	Label	A20001063	1
45	Sight glass bezel	A20416002	1
69	Sight glass seal	A26501012	1
71	Spray baffle	A25976033	1
78	Oil box gasket	A27159629	1
82	Ball valve - 1/2 inch BSP	A28702003	1
83	Sight glass	A29201006	1
114	Redcap - 1/2 inch BSP	H01503333	1
116	Dowty seal - 1 inch BSP	H02104008	1
146	Rivet	211430301	4
169	Soc. hd. cap scr. M5 x 16 lg.	218091330	8
171	Soc. hd. cap scr. M6 x 12 lg.	218091369	3
178	Soc. hd. cap scr. M8 x 70 lg.	218091416	6
188	Rect. sect. s /coil spring washer M8	218985810	6
191	Hazard warning label	A20001084	1

E E2M40 HV stator sub-assembly

Figure 13 - (E) E2M40 HV stator sub-assembly

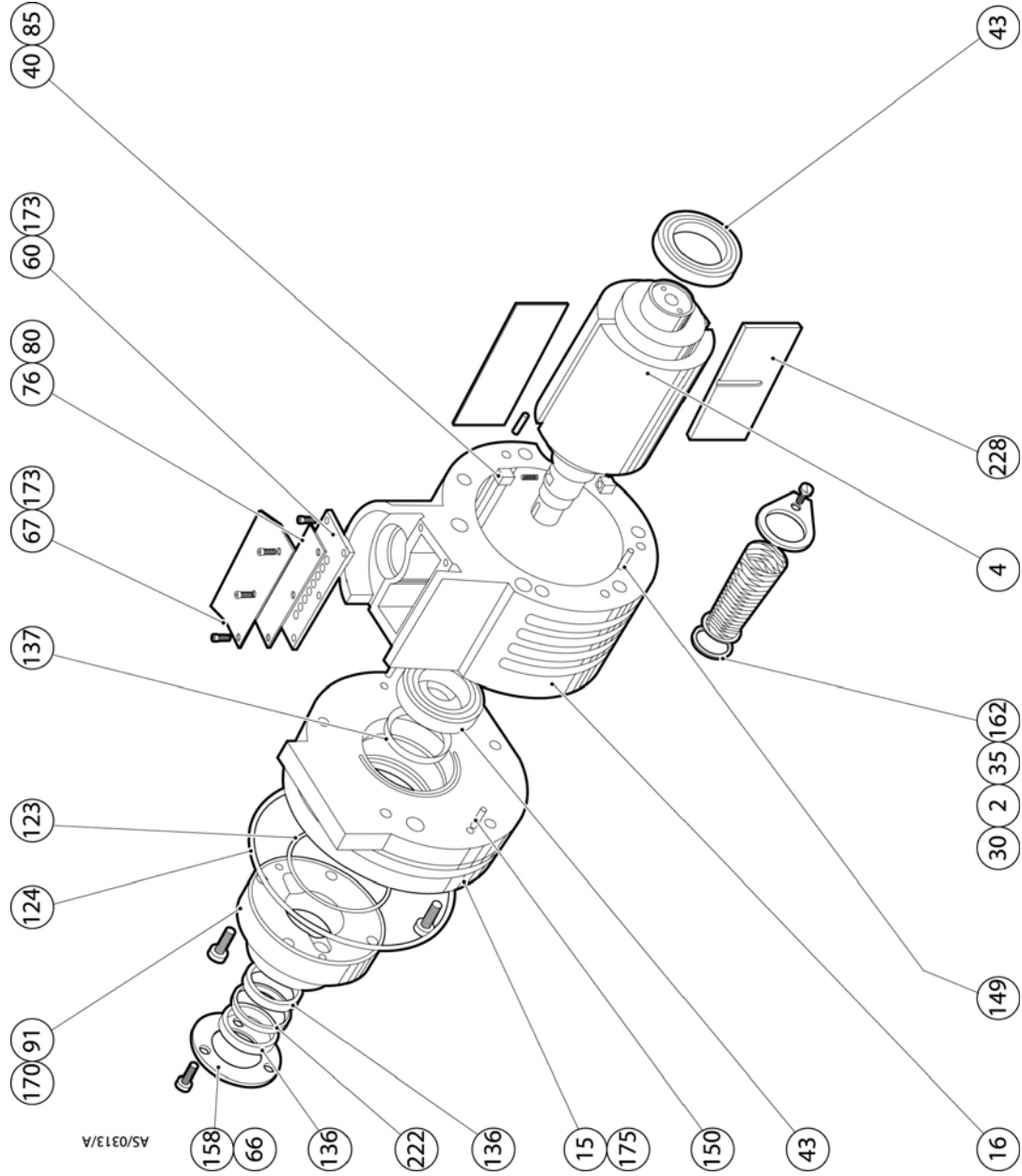

Table 12 - E2M40 HV stator sub-assembly items

Item	Description	Code No.	Qty
2	Filter assy (oil)	A22305050	1
4	Rotor - High Vac. (Spare)	A26401770	1
15	Front bearing	A36401001	1
16	High Vac. stator (Spare)	A36401702	1
30	Filter seal	A01403030	1
35	Clamp plate	A36401031	1
40	Oil pump blade	A20402418	2
43	Roller bearing	A20404011	2
60	Exhaust cover plate	A25942008	1
66	Seal retainer	A25971002	1
67	Exhaust valve plate	A25976006	1
76	Exhaust valve rubber	A27159514	1
80	Exhaust valve spacer	A27804004	3
85	Spring	A27102024	1
91	Oil pump housing	A36501014	1
123	O-ring 64.5 mm i/d x 3.0 mm sect.	H02120082	1
124	O-ring 139.5 mm i/d x 3.0 mm sect.	H02120097	1
136	Oil seal	H02109094	2
137	Oil seal	H02109064	1
149	Taper pin $\varnothing 8$ x 36 lg.	212192021	2
150	Taper pin $\varnothing 8$ x 60 lg.	212192026	2
158	C'sk. hd. scr M5 x 10 lg.	218032328	3
162	Pan hd. scr. ssM5 x 10 lg.	218221328	1
170	Soc hd. cap scr. M5 x 25 lg.	218091332	4
173	Soc hd. cap scr. M6 x 20 lg.	218091371	5
175	Soc hd. cap scr. M8 x 25 lg.	218091412	5
205	Spiroseal	H02109065	1
206	Positive action shaft seal	H02109075	1
222	Aluminium spacer	A26426001	1
208	High Vac. blade	A20402162	2

Table 13 - E2M40 LV stator sub-assembly items

Item	Description	Code No.	Qty
5	Low Vac. rotor assy. (Spare)	A26401740	1
7	Tube assy. (ballast)	A34401007	1
8	Tube assy. (oil delivery)	A34401006	1
17	Interstage	A36401030	1
23	Low Vac. stator (Spare)	A36401712	1
24	End cover (Spare)	A36401713	1
61	Clamp (oil delivery line)	A25970035	2
63	Low Vac. exhaust baffle	A25970038	1
68	Low Vac. exh. plate	A25976007	1
77	Low Vac. exh. valve rubber	A27159515	1
80	Exh. valve spacer	A27804004	1
120	O-ring 9.6 mm i/d x 2.4 mm sect.	H02120031	1
129	O-ring 5/16 inch i/d x 3/32 inch sect.	H02125116	4
145	Spring pin \varnothing 1/4 inch x 1/2 inch lg.	211174099	1
149	Taper pin \varnothing 8 x 36 lg.	212192021	2
161	Pan hd. scr. M4 x 8 lg.	218042287	2
162	Pan hd. scr. ssM5 x 10 lg.	218221328	2
168	Soc hd. cap scr. M5 x 10 lg.	218091328	2
171	Soc hd. cap scr. M6 x 12 lg.	218091369	1
175	Soc hd. cap scr. M8 x 25 lg.	218091412	7
177	Soc hd. cap scr. M8 x 50 lg.	218091417	4
179	Soc hd. cap scr. M10 x 30 lg.	218091453	1
180	Soc set scr. cup pt. M10 x 12 lg.	218121449	1
229	Low Vac. blade	A20402163	2

Table 13a - E2M40 LV rotor sub-assembly items

Item	Description	Code No.	Qty
1	Low vac rotor	A26402002	1
2	Inner ring	A20405010	1
3	Heavy duty spring pin \varnothing 4 x 18 mm lg.	212170758	2

G E2M40 motor plate sub-assembly

Figure 15 - (G) E2M40 motor plate sub-assembly

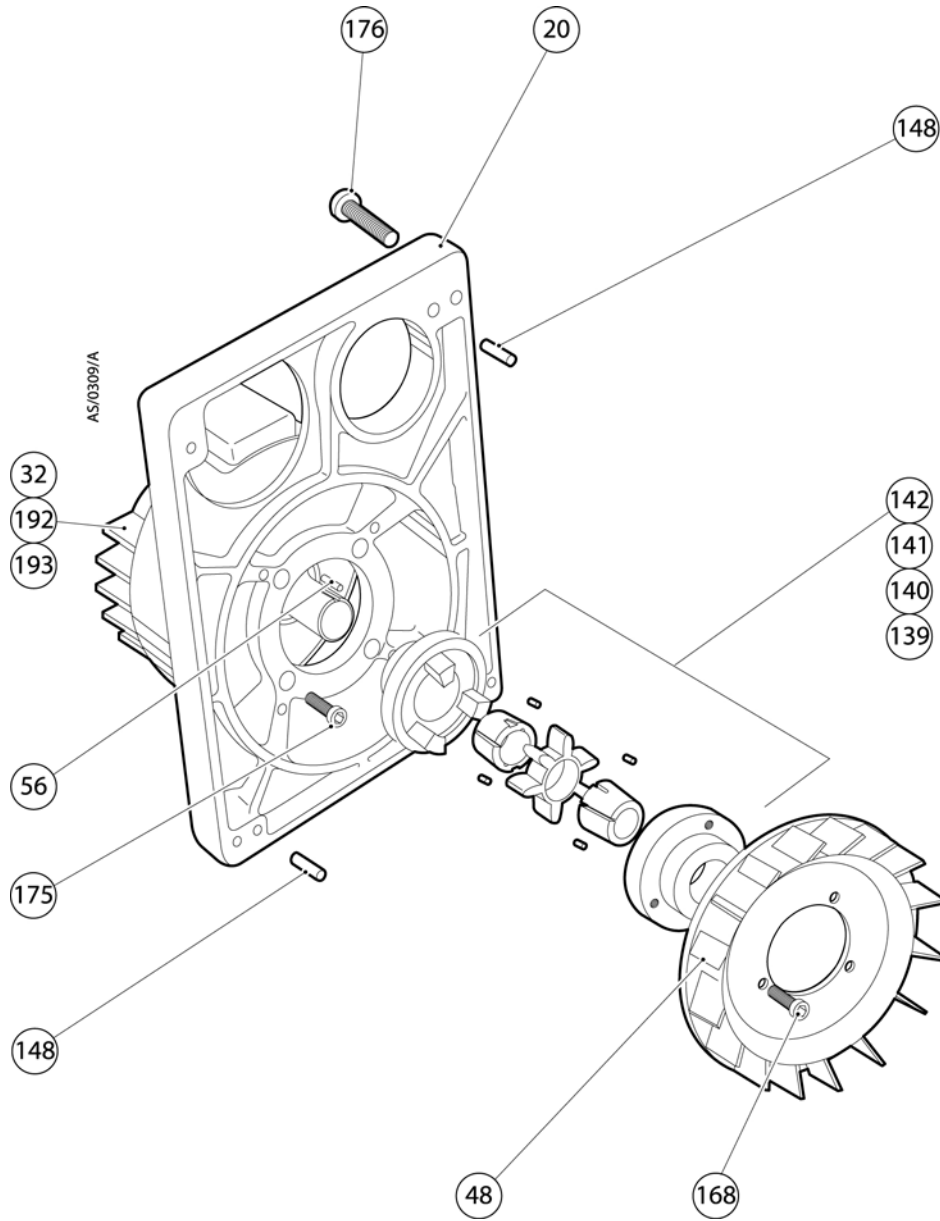

Table 14 - E2M40 motor plate sub-assembly items

Item	Description	Code No.	Qty
20	Motor mounting	A36401008	1
32	E2M40 Motor - see Table 1b	-----	1
48	Fan	A22301003	1
56	Key - 8 x 7 x 20 lg.	A24301008	1
139	Flexible component	A21071033	1
140	Coupling flange	A21071037	1
141	Coupling flange	A21071038	1
142	Taper lock bush	A21071039	2
148	Parallel dowel - ø8 x 24 lg.	212181076	2
168	Soc. hd. cap scr. M5 x 10 lg.	218091328	3
175	Soc. hd. cap scr. M8 x 25 lg.	218091412	4
176	Soc. hd. cap scr. M8 x 40 lg.	218091415	4
192	Electrical warning label	E20001063	1
193	Direction label	A20001085	1

This page has been intentionally left blank.

5 E1M80 major sub-assemblies

Figure 16 - E1M80 major sub-assemblies

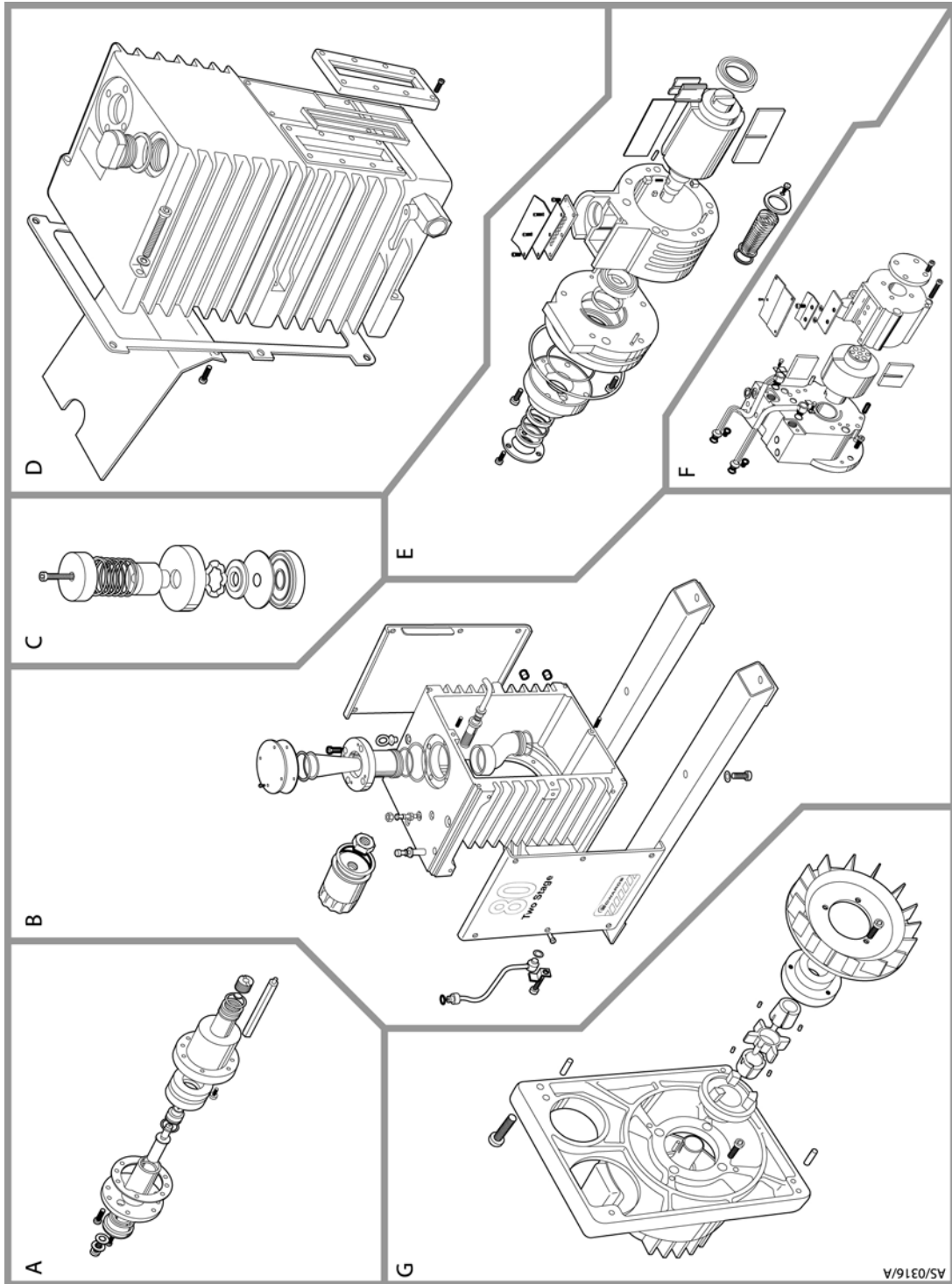

E1M80 major sub-assemblies

A E1M80 gas ballast valve sub-assembly

Figure 17 - (A) E1M80 gas ballast valve sub-assembly

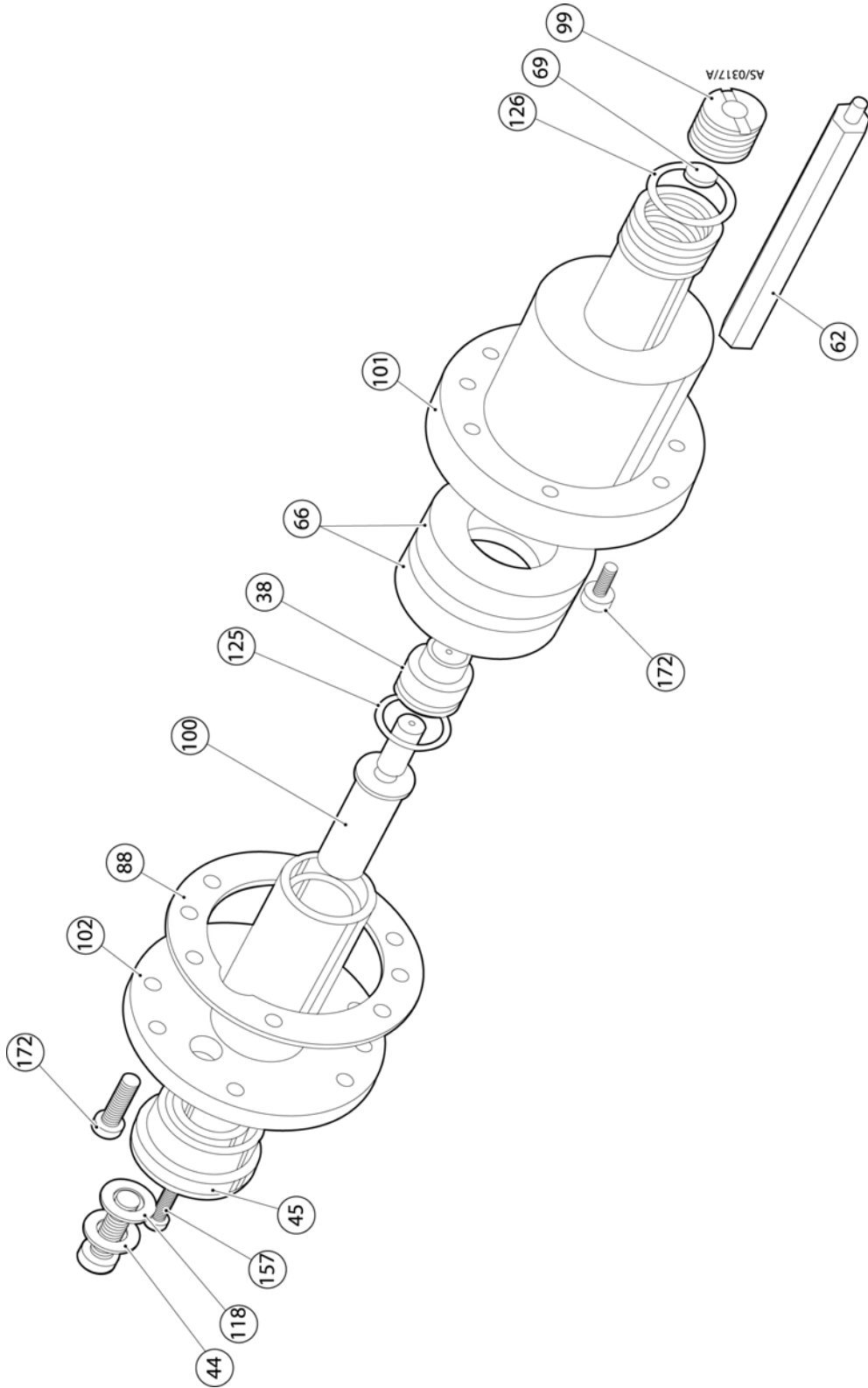

Table 15 - E1M80 gas ballast valve sub-assembly items

Item	Description	Code No.	Qty
38	Ballast piston	A19201008	1
44	Plug - 1/4 inch BSP	A26002018	1
45	Ballast knob	A19201013	1
62	Support pillar	A22404006	2
66	Ballast filter	A22305041	2
69	Ballast valve	A25904601	1
88	Body gasket	A27159428	1
99	Ballast plug	A36601034	1
100	Ballast spindle	A36601036	1
101	Ballast valve body	A34401008	1
102	Ballast valve bearing	A34401009	1
118	Dowty seal - 1/4 inch BSP	H02104002	1
125	O-ring 7/16 inch i/d x 3/32 inch sect	H02125011	1
126	O-ring 3/4 inch i/d x 1/8 inch sect.	H02126020	1
157	C'sk hd. scr. M4 x 16 lg.	218032290	1
172	Soc. hd. cap scr. M6 x 16 lg.	218091370	8

B E1M80 adaptor sub-assembly

Figure 18 - (B) E1M80 adaptor sub-assembly

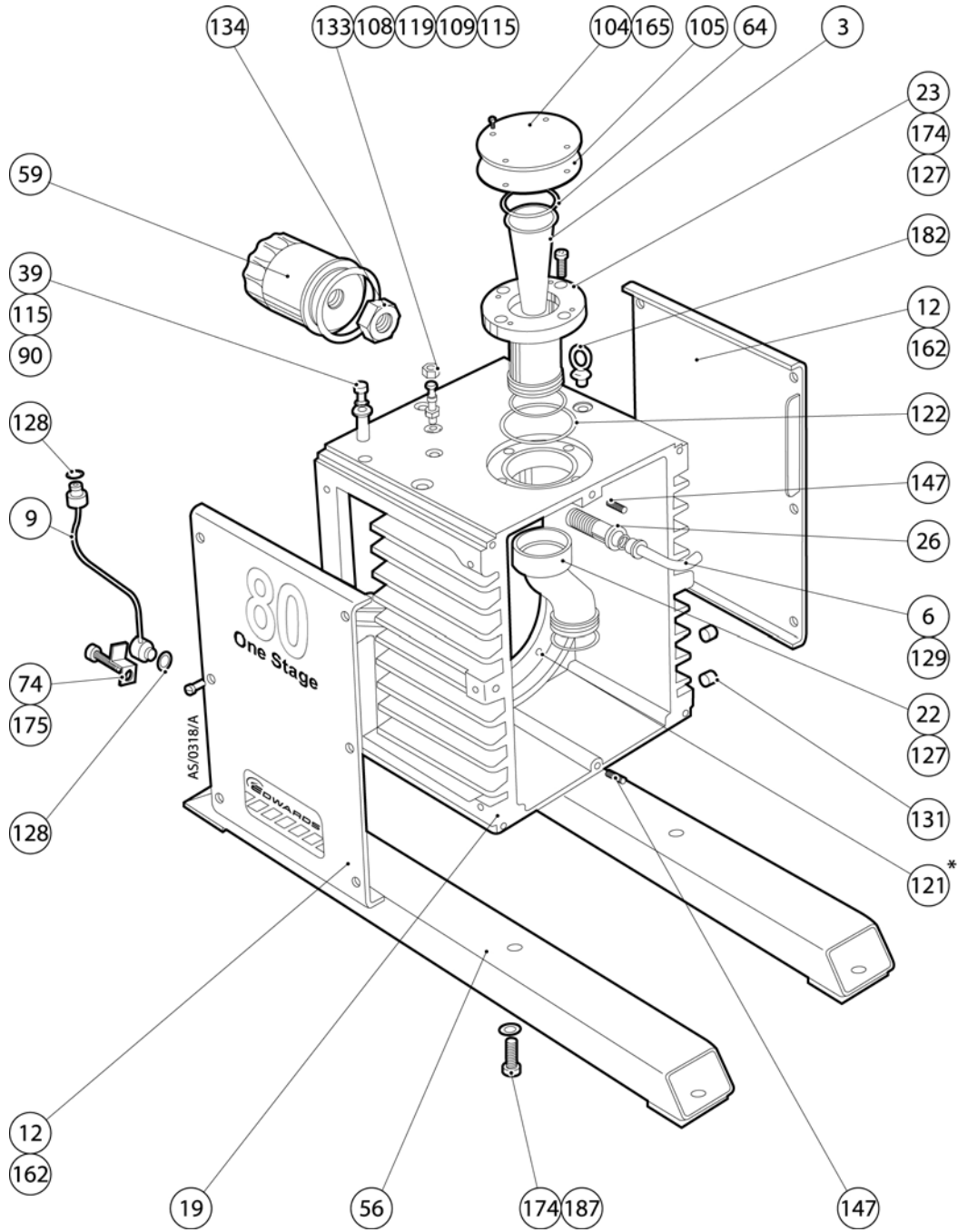

Table 16 - E1M80 adaptor sub-assembly items

Item	Description	Code No.	Qty
3	Filter assy. (inlet)	A22305035	1
6	Tube assy. (oil return)	A27879001	1
9	Tube assy. (oil pressure)	A27879007	1
12	Side panel	A34501005	2
19	Adaptor	A36501045	1
22	Inlet connection	A36501009	1
23	Inlet flange	A36501032	1
26	Filter outlet	A36501013	1
39	Plug - 1/8 inch BSP	A01403074	1
56	Base runner	A20499015	2
59	Filter	A22304041	1
64	Circlip	A22426004	1
74	Clamp (oil pressure line)	A25970036	1
90	1/8 inch BSP socket	A27911003	1
104	Protective cover	B21023019	1
105	Dust cover	B21024001	1
108	Blind tailpiece	C11001062	1
109	Adaptor - sc 5 mm x 1/8 inch BSP	C11001180	1
115	Dowty seal -1/8 inch BSP	H02104001	2
119	O-ring 6.5 mm i/d x 2.4 mm sect.	H02120027	1
121	O-ring 12.42 mm i/d x 1.78 mm sect. Fluoro	H02124119	1
122	O-ring 61.6 mm i/d x 2.4 mm sect.	H02120057	1
127	O-ring 17/8 inch i/d x 3/16 inch sect.	H02125044	2
128	O-ring 3/8 inch i/d x 3/32 inch sect.	H02125115	2
129	O-ring 5/16 inch i/d x 3/32 inch sect.	H02125116	1
131	1/4 inch BSP hollow taper pressure plug	H03517003	2
133	Union nut - 3/8 inch BSP	M03400008	1
134	Locknut - 3/4 inch x 16UNF ms. ni. pl.	216814314	1
147	Spring pin - \varnothing 8 x 24 1g.	212170186	2
162	Pan hd. scr. ss M5 x 10	218221328	12
165	Hex hd. scr. M8 x 12 1g.	218072409	2
174	Soc. hd. cap scr. M8 x 20 lg.	218091411	8
175	Soc. hd. cap scr. M8 x 25 lg.	218091412	1
182	Eyebolt - M12	218790005	2
187	Plain washer	218980210	4

C E1M80 oil distributor sub-assembly

Figure 19 - (C) E1M80 oil distributor sub-assembly

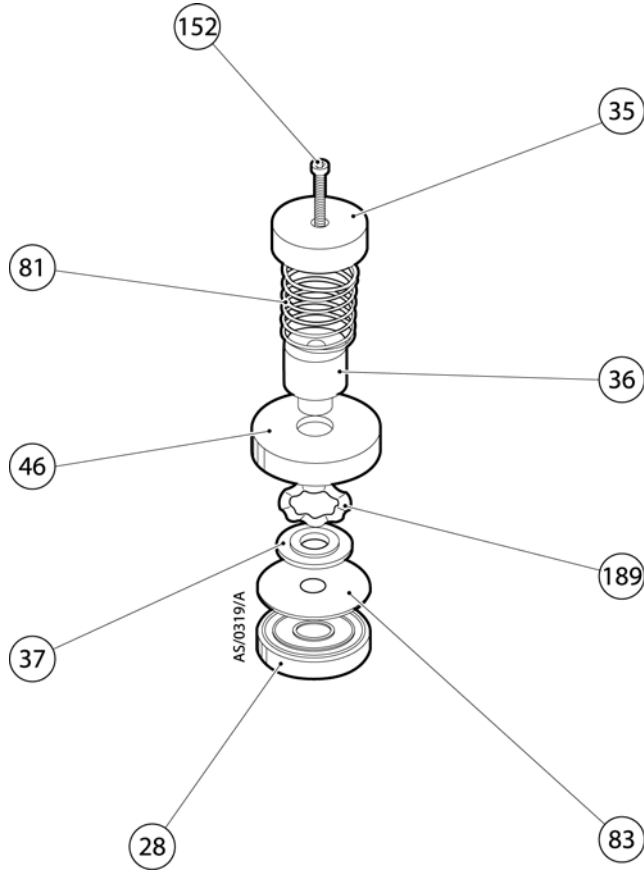

Table 17 - E1M80 oil distributor sub-assembly items

Item	Description	Code No.	Qty
28	Distributor body	A36501015	1
35	Spacer	A36401029	1
36	Distributor sleeve	A36401019	1
37	Distributor weight	A34301037	1
46	Cap	A36401028	1
81	Spring	A27102013	1
83	Rubber seal	A37159415	1
152	Hex hd. scr. ms. ni. pl. M5 x 60 lg.	218002339	1
189	Waved washer	218990201	1

Table 18 - E1M80 oil box sub-assembly items

Item	Description	Code No.	Qty
20	Oil box	A36501034	1
42	Filler plug - 1 inch BSP	A26002022	1
49	Label	A20001063	1
55	Sight glass bezel	A20416002	1
79	Sight glass seal	A26501012	1
80	Spray baffle	A25976034	1
87	Oil box gasket	A27159618	1
91	Sight glass	A29201006	1
93	Ball valve - 1/2 inch BSP	A28702003	1
114	Redcap -1/2 inch BSP	H01503333	1
116	Dowty seal - 1 inch BSP	H02104008	1
146	Rivet	211430301	4
169	Soc. hd. cap scr. M5 x 16 lg.	218091330	8
171	Soc. hd. cap scr. M6 x 12 lg.	218091369	3
176	Soc. hd. cap scr. M8 x 45 lg.	218091416	6
188	Rect. sect. s/coil spring washer M8	218982710	6
191	Hazard warning label	A20001084	1

Table 19 - E1M80 HV stator sub-assembly items

Item	Description	Code No.	Qty
2	Filter assy. (oil)	A22305050	1
4	Rotor- High Vac. (Spare)	A26401781	1
7	Tube assy. (ballast)	A36501038	1
8	Tube assy. (oil delivery)	A36501036	1
13	High Vac. stator	A34501002	1
14	Rear cover (Spare)	A34501708	1
15	Front bearing	A36501001	1
27	Oil pump housing	A36501014	1
41	Filter seal	A01403030	1
47	Clamp ring	A36401031	1
52	Oil pump blade	A20402418	2
53	Roller bearing	A20404012	2
65	Key - 8 x 7 x 20 lg.	A24301008	1
71	Exhaust baffle	A25970032	1
73	Clamp (oil delivery line)	A25970035	2
76	Seal retainer	A25971002	1
78	Exhaust valve plate	A25976005	1
86	Exhaust valve rubber	A27159509	1
89	Exhaust valve spacer	A27804004	4
94	Spring	A27102024	1
120	O-ring 9.6 mm i/d x 2.4 mm sect.	H02120031	1
123	O-ring 64.5 mm i/d x 3.0 mm sect.	H02120082	1
124	O-ring 159.5 mm i/d x 3.0 mm sect.	H02120101	1
129	O-ring 5/16 inch i/d x 3/32 inch sect.	H02125116	4
136	Oil seal 25 x 35 x 7 mm	H02109094	2
137	Oil seal 30 x 40 x 7 mm	H02109064	1
145	Spring pin \varnothing 1/4 inch x 1/2 inch lg.	211174099	1
149	Taper pin \varnothing 8 x 36 lg.	212192021	2
150	Taper pin \varnothing 8 x 60 lg.	212192026	2
158	C'sk. hd. scr. M5 x 10 lg.	218032328	3
162	Pan hd. scr. ssM5 x 10 lg.	218221328	3
168	Soc hd. cap scr. M5 x 10 lg.	218091328	2
170	Soc hd. cap scr. M5 x 25 lg.	218091332	4
171	Soc hd. cap scr. M6 x 12 lg.	218091369	2
172	Soc hd. cap scr. M6 x 16 lg.	218091370	4
175	Soc hd. cap scr. M8 x 25 lg.	218091412	10
231	Aluminium spacer	A26426001	1
235	High Vac. blade	A20402164	2

Table 20 - E1M80 motor plate sub-assembly items

Item	Description	Code No.	Qty
21	Motor mounting	A36501027	1
43	E1M80 Motor - see Table 1c		1
58	Fan	A22301003	1
67	Key - 8 x 5 x 20 lg.	A24301013	1
139	Flexible component	A21071033	1
140	Coupling flange	A21071037	1
141	Coupling flange	A21071038	1
142	Taper lock bush	A21071039	1
143	Taper lock bush	A21071040	1
148	Parallel dowel - ø8 x 24 lg.	212181076	2
168	Soc. hd. cap scr. M5 x 10 lg.	218091328	3
175	Soc. hd. cap scr. M8 x 25 lg.	218091412	4
177	Soc. hd. cap scr. M8 x 40 lg.	218091415	4
192	Electrical warning label	E20001063	1
193	Direction label	A20001085	1

This page has been intentionally left blank.

6 E2M80 major sub-assemblies

Figure 23 - E2M80 major sub-assemblies

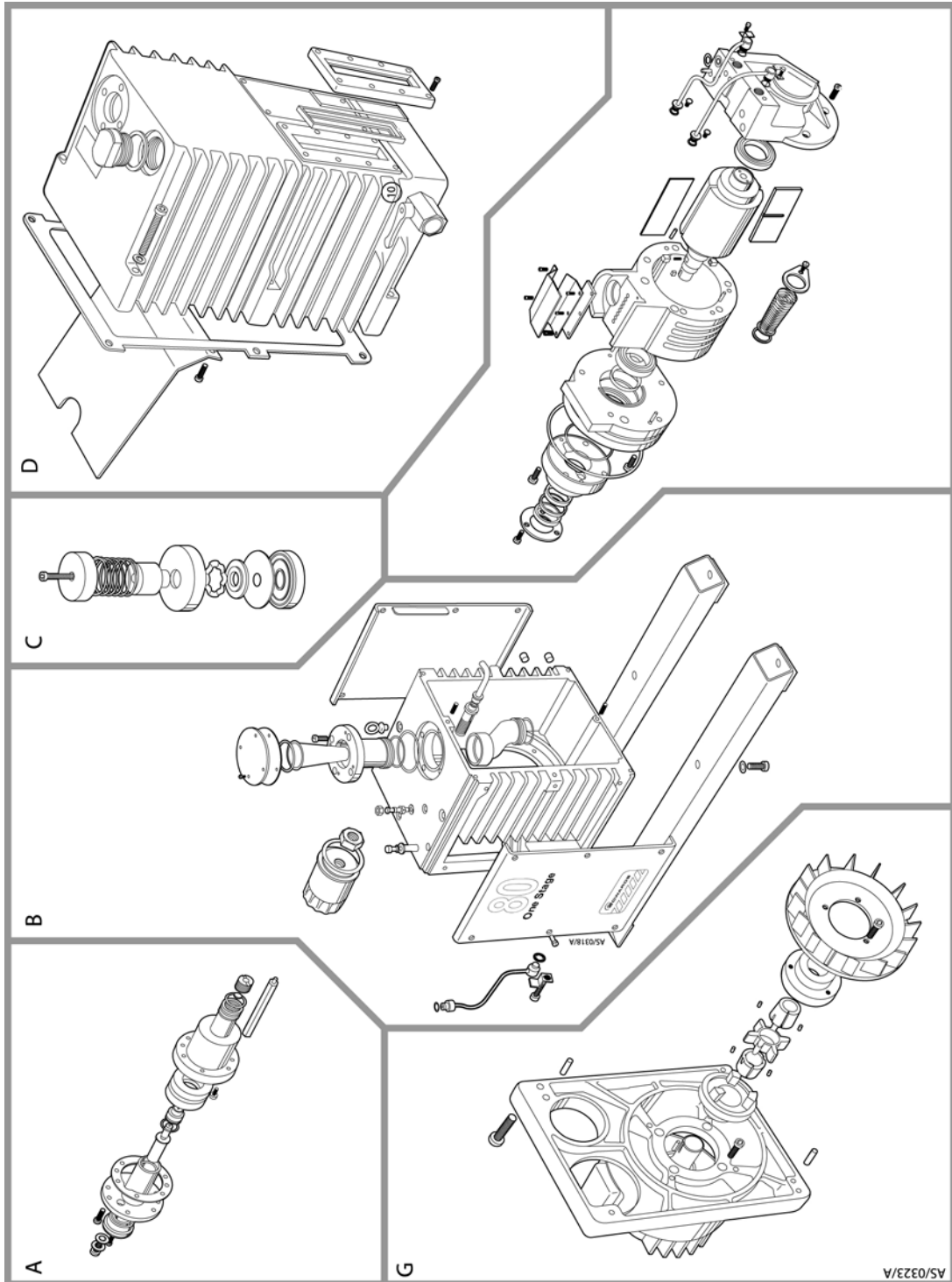

A E2M80 gas ballast valve sub-assembly

Figure 24 - (A) E2M80 gas ballast valve sub-assembly

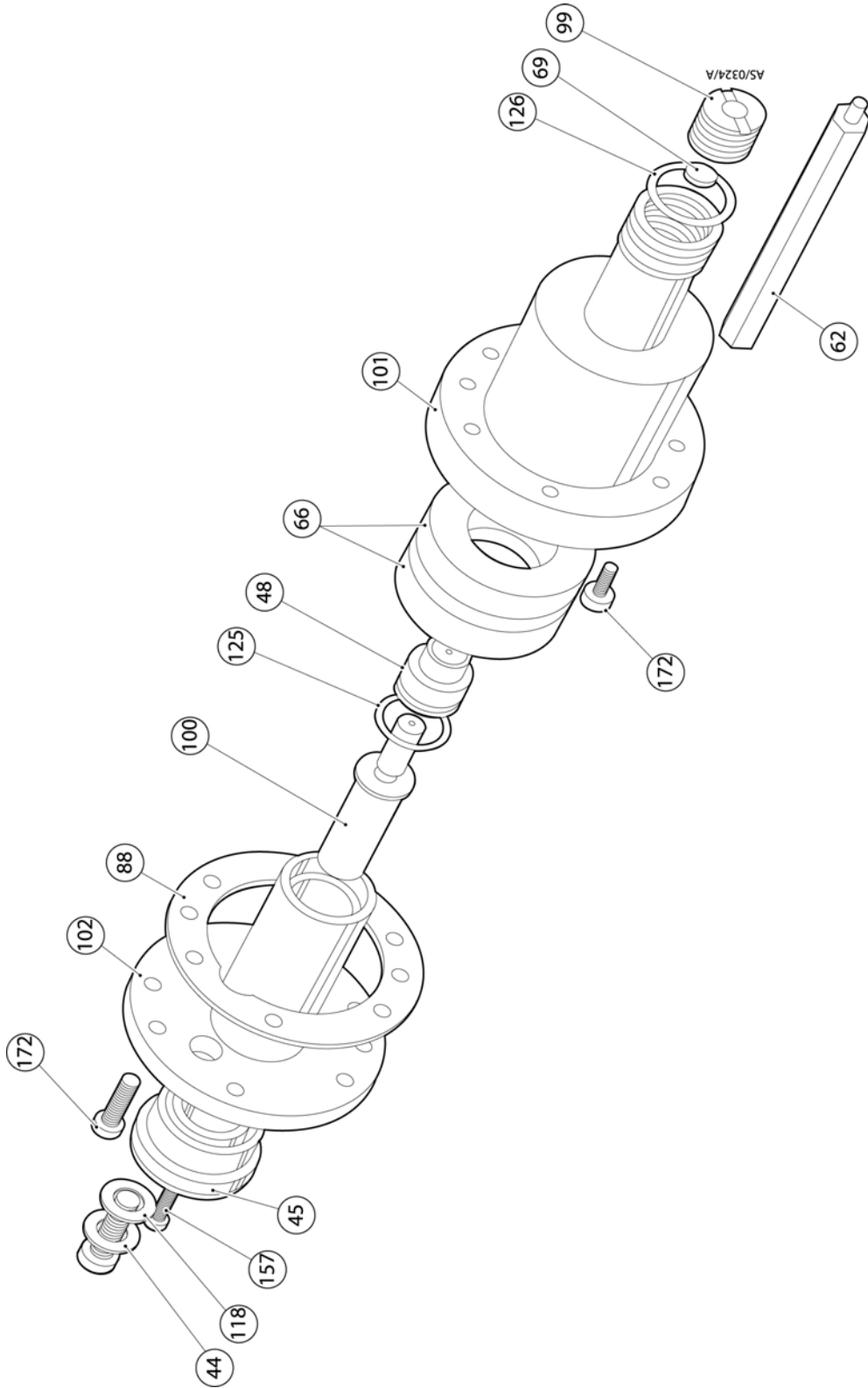
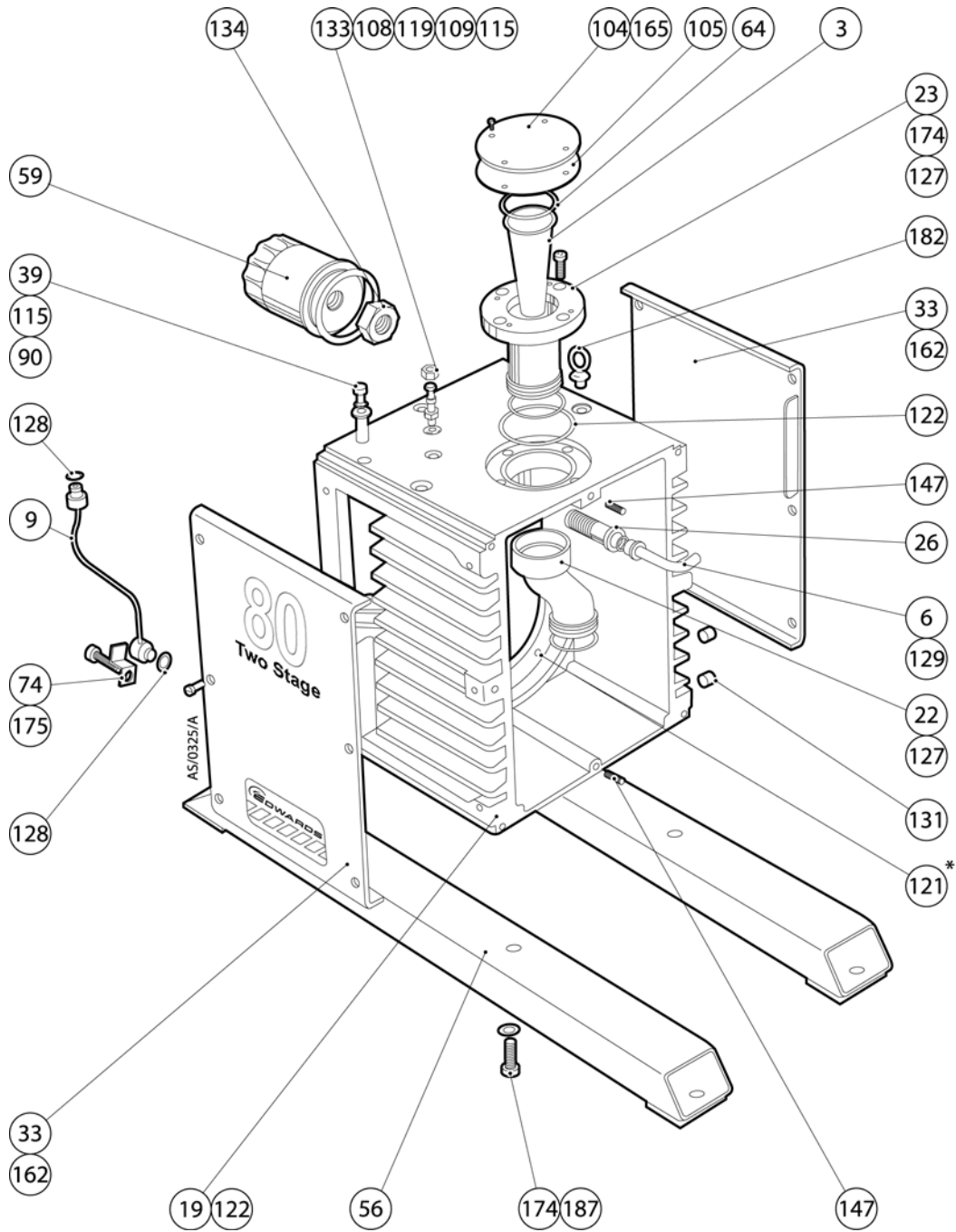

Table 21 - E2M80 gas ballast valve sub-assembly items

Item	Description	Code No.	Qty
44	Plug - 1/4 inch BSP	A26002018	1
45	Ballast knob	A19201013	1
48	Ballast piston	A19201007	1
62	Support pillar	A22404006	2
66	Ballast filter	A22305041	2
69	Ballast valve	A25904601	1
88	Body gasket	A27159428	1
99	Ballast plug	A36601034	1
100	Ballast spindle	A36601036	1
101	Ballast valve body	A34401008	1
102	Ballast valve bearing	A34401009	1
118	Dowty seal - 1/4 inch BSP	H02104002	1
125	O-ring 7/16 inch i/d x 3/32 inch sect	H02125011	1
126	O-ring 3/4 inch i/d x 1/8 inch sect.	H02126020	1
157	C'sk hd. scr. M4 x 16 1g.	218032290	1
172	Soc. hd. cap scr. M6 x 16 1g.	218091370	8

B E2M80 adaptor sub-assembly

Figure 25 - (B) E2M80 adaptor sub-assembly



* Used on item 15 (ref. Figure 28)

Table 22 - E2M80 adaptor sub-assembly items

Item	Description	Code No.	Qty
3	Filter assy. (inlet)	A22305035	1
6	Tube assy. (oil return)	A27879001	1
9	Tube assy. (oil pressure)	A27879007	
19	Adaptor	A36501045	1
22	Inlet connection	A36501009	1
23	Inlet flange	A36501032	1
26	Filter outlet	A36501013	1
33	Side panel	A36501046	2
39	Plug - 1/8 inch BSP	A01403074	1
56	Base runner	A20499015	2
59	Filter	A22304041	1
64	Circlip	A22426004	1
74	Clamp (oil pressure line)	A25970036	
90	1/8 inch BSP socket	A27911003	
104	Protective cover	B21023019	1
105	Dust cover	B21024001	
108	Blind tailpiece	C11001062	1
109	Adaptor- sc5 mm x 1/8 inch BSP	C11001180	
115	Dowty seal - 1/8 inch BSP	H02104001	2
119	O-ring 6.5 mm i/d x 2.4 mm sect.	H02120027	
121	O-ring 12.42 mm i/d x 1.78 mm sect. Fluoro	H02124119	
122	O-ring 61.6 mm i/d x 2.4 mm sect.	H02120057	1
127	O-ring 17/8 inch i/d x 3/16 inch sect.	H02125044	2
128	O-ring 3/8 inch i/d x 3/32 inch sect.	H02125115	2
129	O-ring 5/16 inch i/d x 3/32 inch sect.	H02125116	1
131	1/4 inch BSP hollow taper pressure plug	H03517003	2
133	Union nut - 3/8 inch BSP	M03400008	
134	Locknut - 3/4 inch x 16UNF ms. ni. pl.	216814314	1
147	Spring pin - $\varnothing 8$ x 24 lg.	212170186	2
162	Pan hd. scr. ss M5 x 10	218221328	12
165	Hex hd. scr. M8 x 12 lg.	218072409	2
174	Soc. hd. cap scr. M8 x 20 lg.	218091411	8
175	Soc. hd. cap scr. M8 x 25 lg.	218091412	1
182	Eyebolt - M12	218790005	2
187	Plain washer	218980210	4

C E2M80 oil distributor sub-assembly

Figure 26 - (C) E2M80 oil distributor sub-assembly

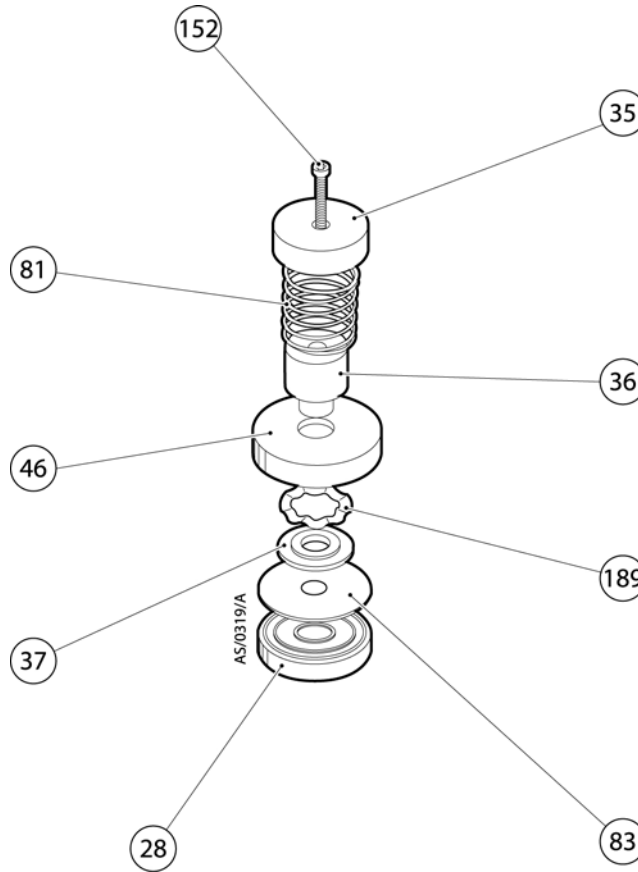

Table 23 - E2M80 oil distributor sub-assembly items

Item	Description	Code No.	Qty
28	Distributor body	A36501015	1
35	Spacer	A36401029	1
36	Distributor sleeve	A36401019	1
37	Distributor weight	A34301037	1
46	Cap	A36401028	1
81	Spring	A27102013	1
83	Rubber seal	A27159415	1
152	Hex hd. scr. ms. ni. pl. M5 x 60 lg.	218002339	1
189	Waved washer	218990201	1

D E2M80 oil box sub-assembly

Figure 27 - (D) Oil box sub-assembly

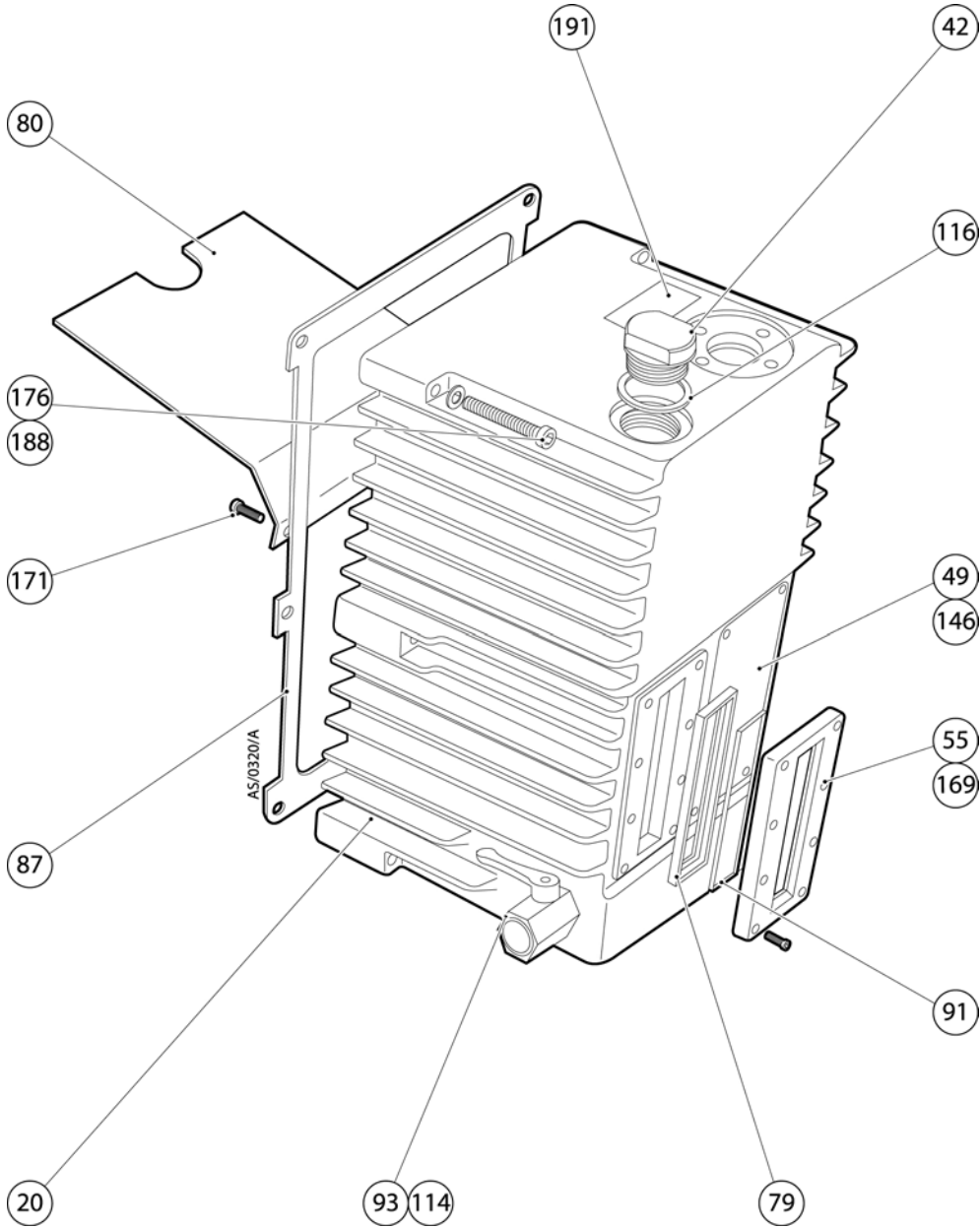

Table 24 - E2M80 oil box sub-assembly items

Item	Description	Code No.	Qty
20	Oil box	A36501034	1
42	Filler plug - 1 inch BSP	A26002022	1
49	Label	A20001063	1
55	Sight glass bezel	A20416002	1
79	Sight glass seal	A26501012	1
80	Spray baffle	A25976034	1
87	Oil box gasket	A27159618	1
91	Sight glass	A29201006	1
93	Ball valve -1/2 inch BSP	A28702003	1
114	Redcap - 1/2 inch BSP	H01503333	1
116	Dowty seal - 1 inch BSP	H02104008	1
146	Rivet	211430301	4
169	Soc. hd. cap scr. M5 x 16 lg.	218091330	8
171	Soc. hd. cap scr. M6 x 12 lg.	218091369	3
176	Soc. hd. cap scr. M8 x 45 lg.	218091416	6
188	Rect. sect. s/coil spring washer M8	218982710	6
191	Hazard warning label	A20001084	1

E E2M80 HV stator sub-assembly

Figure 28 - (E) E2M80 HV stator sub-assembly

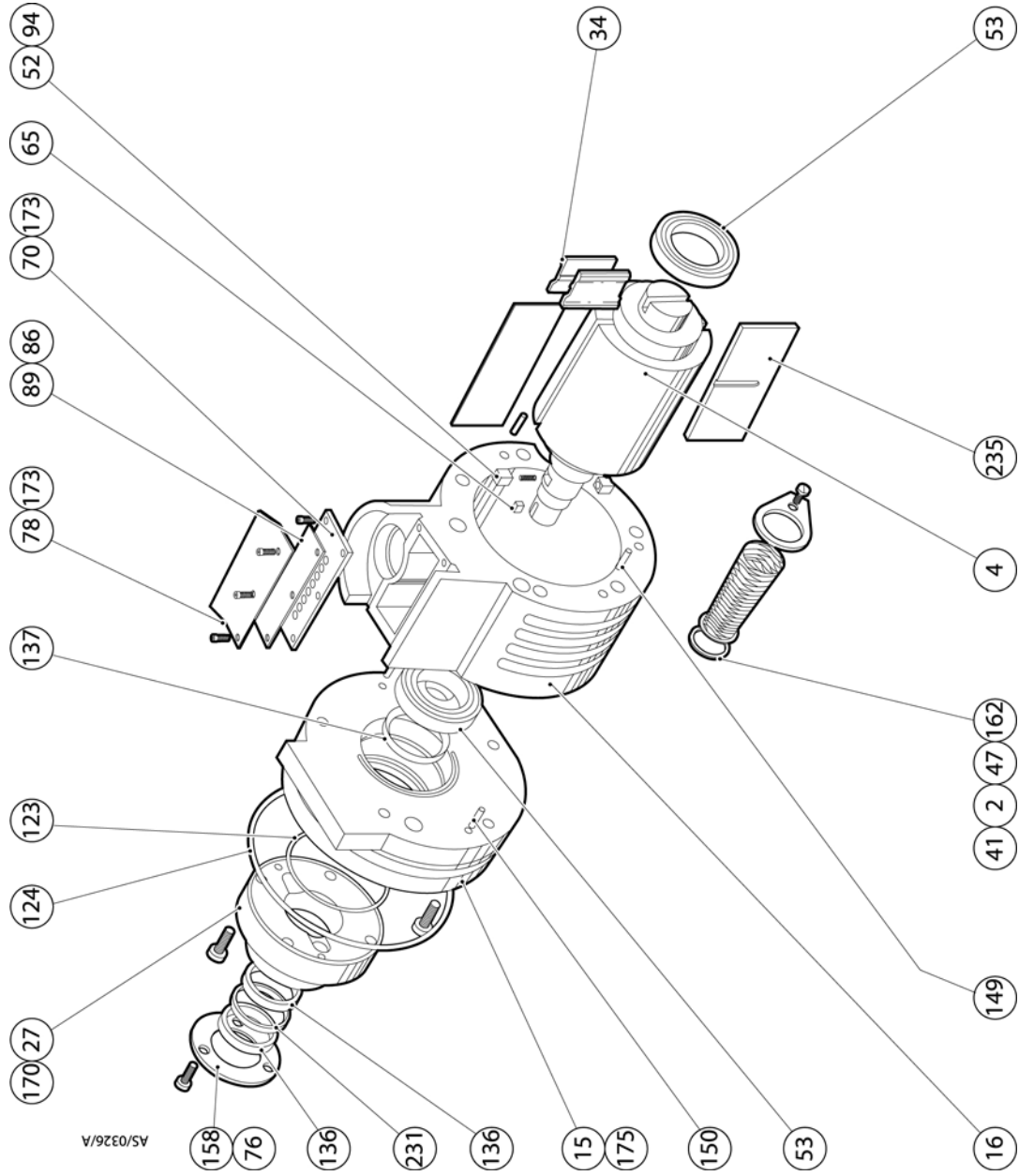

Table 25 - E2M80 HV stator sub-assembly items

Item	Description	Code No.	Qty
2	Filter assy. (oil)	A22305050	1
4	Rotor- High Vac. (Spare)	A26401781	1
15	Front bearing	A36501001	1
16	High Vac. stator	A36501002	1
27	Oil pump housing	A36501014	1
34	Drive member	A36501024	2
41	Filter seal	A01403030	1
47	Clamp ring	A36401031	1
52	Oil pump blade	A20402418	2
53	Roller bearing	A20404012	2
65	Key - 8 x 7 x 20 lg.	A24301008	1
70	Exhaust cover plate	A25942005	1
76	Seal retainer	A25971002	1
78	Exhaust valve plate	A25976005	1
86	Exhaust valve rubber	A27159509	1
89	Exhaust valve spacer	A27804004	4
94	Spring	A27102024	1
123	O-ring 64.5 mm i/d x 3.0 mm sect.	H02120082	1
124	O-ring 159.5 mm i/d x 3.0 mm sect.	H02120101	1
136	Oil seal 25 x 35 x 7 mm	H02109094	2
137	Oil seal 30 x 40 x 7 mm	H02109064	1
149	Taper pin Ø8 x 36 lg.	212192021	2
150	Taper pin Ø8 x 60 lg.	212192026	2
158	C'sk. hd. scr M5 x 10 lg.	218032328	3
162	Pan hd. scr. ssM5 x 10 lg.	218221328	1
170	Soc hd. cap scr. M5 x 25 lg.	218091332	4
173	Soc hd. cap scr. M6 x 20 lg.	218091371	8
175	Soc hd. cap scr. M8 x 25 lg.	218091412	5
231	Aluminium spacer	A26426001	1
235	High Vac. blade	A20402164	2

F E2M80 LV stator sub-assembly

Figure 29 - (F) E2M80 LV stator sub-assembly

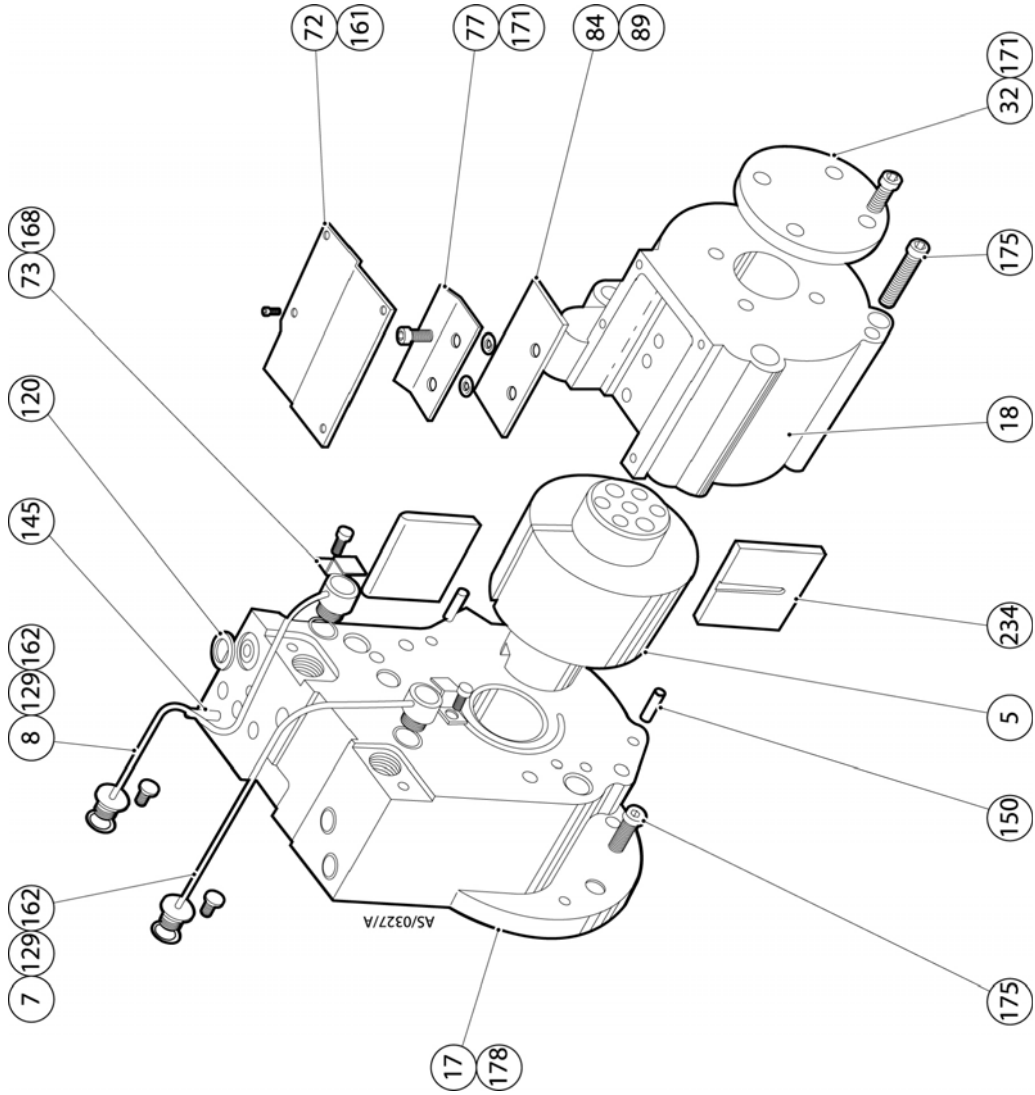

Table 26 - E2M80 LV stator sub-assembly items

Item	Description	Code No.	Qty
5	Low Vac. rotor assy. (Spare)	A26401742	1
7	Tube assy. (ballast)	A36501038	1
8	Tube assy. (oil delivery)	A36501036	1
17	Interstage	A36501035	1
18	Low Vac. stator (Spare)	A36501744	1
32	Cover plate	A36501021	1
72	Low Vac. exhaust baffle	A25970070	1
73	Clamp (oil delivery line)	A25970035	2
77	Low vac exhaust valve plate	A25976048	1
84	Low Vac. exh. valve rubber	A27159541	1
89	Exh. valve spacer	A27804004	2
120	O-ring 9.6 mm i/d x 2.4 mm sect.	H02120031	1
129	O-ring 5/16 inch i/d 3/32 inch sect	H02125116	4
145	Spring pin \varnothing 1/4 inch x 1/2 inch lg.	211174099	1
150	Taper pin \varnothing 8 x 60 lg.	212192026	2
161	Pan hd. scr. M4 x 8 lg.	218042287	2
162	Pan hd. scr. sl. ss. M5 x 10 lg.	218221328	2
168	Soc hd. cap scr. M5 x 10 lg.	218091328	2
171	Soc hd. cap scr. M6 x 12 lg.	218091369	6
175	Soc hd. cap scr. M8 x 25 lg.	218091412	9
178	Soc set scr. cup pt. M10 x 12 1g.	218121449	1
234	Low Vac. blade	A20402165	2

G E2M80 motor plate sub-assembly

Figure 30 - (G) E2M80 motor plate sub-assembly

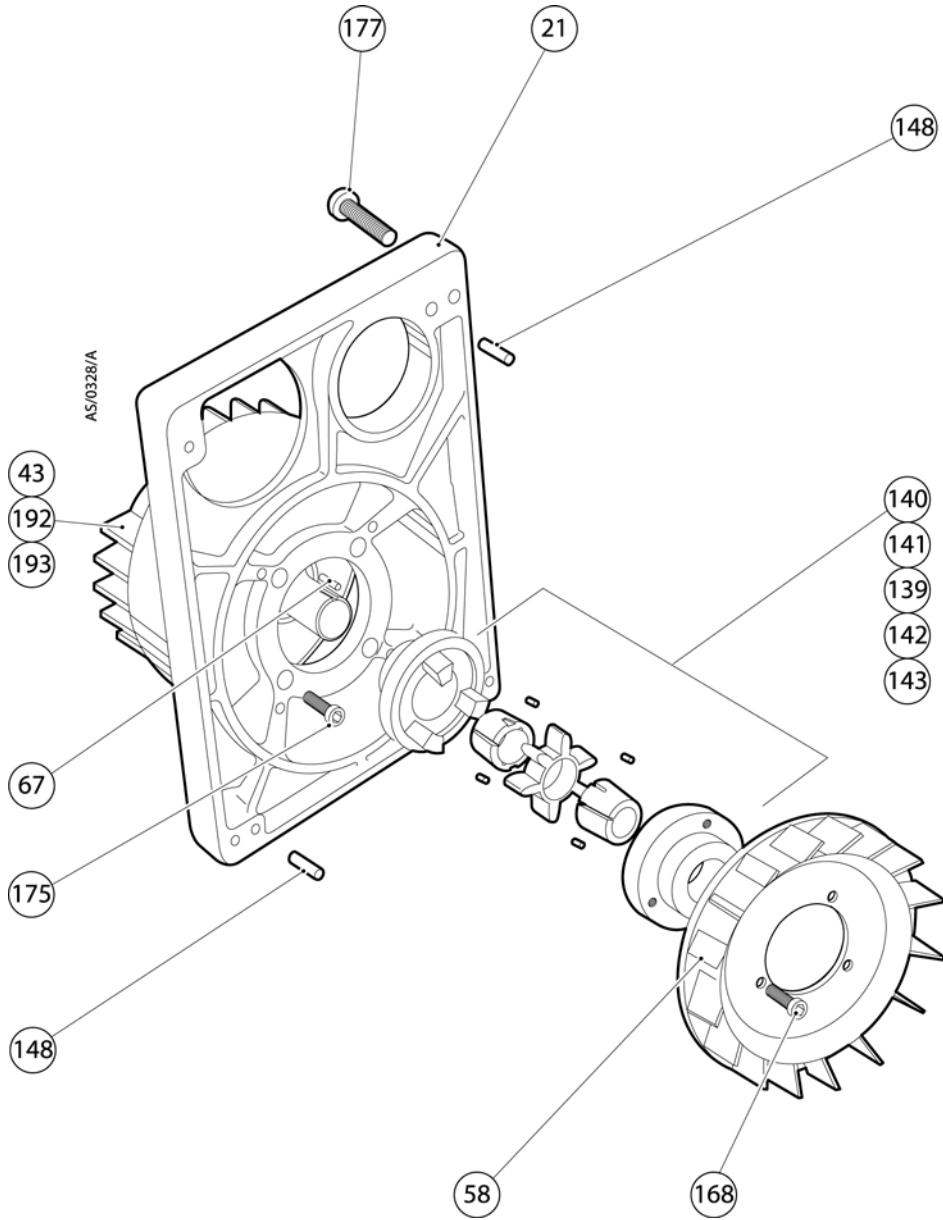

Table 27 - E2M80 motor plate sub-assembly items

Item	Description	Code No.	Qty
21	Motor mounting	A36501027	1
43	E2M80 Motor -see Table 1d		1
58	Fan	A22301003	1
67	Key- 8 x 5 x 20 lg.	A24301013	1
139	Flexible component	A21071033	1
140	Coupling flange	A21071037	1
141	Coupling flange	A21071038	1
142	Taper lock bush	A21071039	1
143	Taper lock bush	A21071040	1
148	Parallel dowel - ø8 x 24 lg.	212181076	2
168	Soc. hd. cap scr. M5 x 10 lg.	218091328	3
175	Soc. hd. cap scr. M8 x 25 lg.	218091412	4
177	Soc. hd. cap scr. M8 x 40 lg.	218091415	4
192	Electrical warning label	E20001063	1
193	Direction label	A20001085	1

This page has been intentionally left blank.

7 E1M/E2M40/80 ATEX special items

Figure 31 - E1M/E2M40/80 ATEX special items

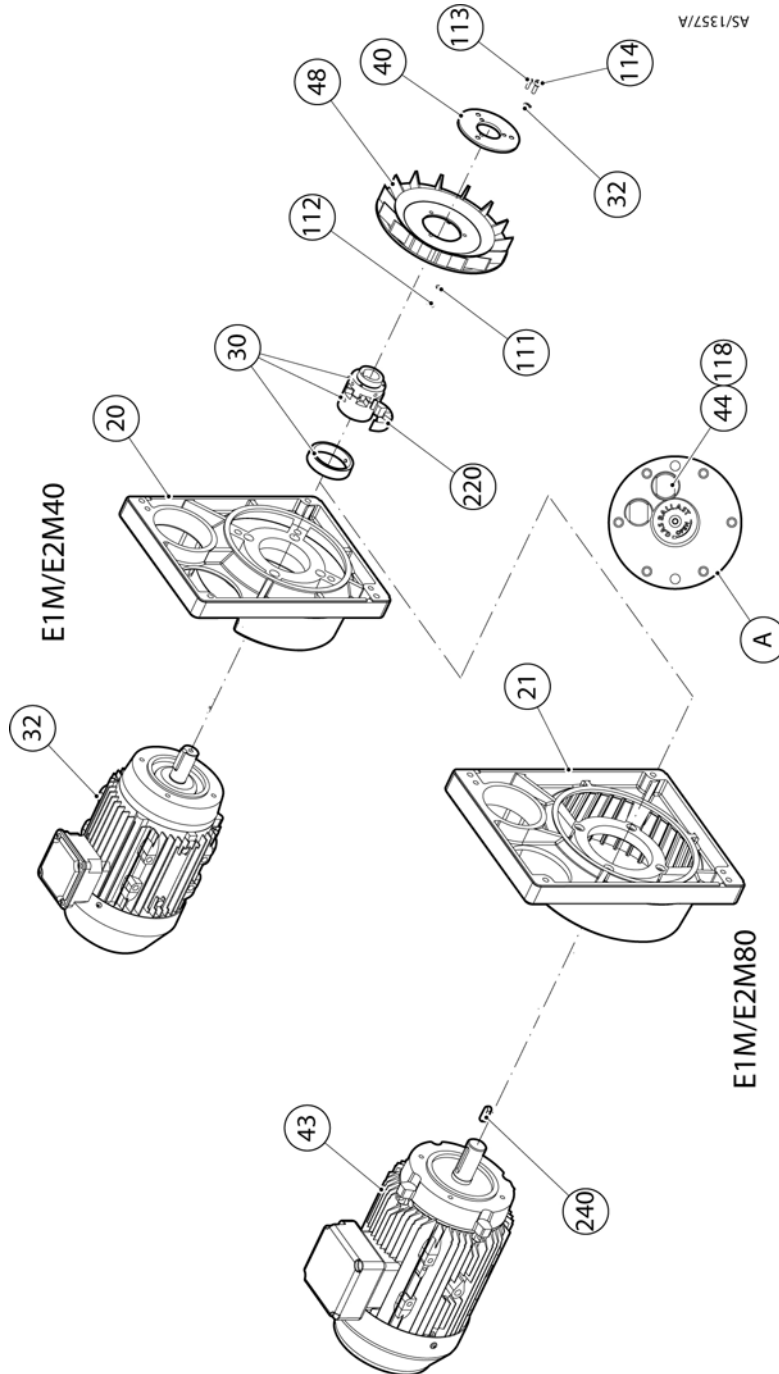

E1M/E2M40/80 ATEX special items

Table 28 - E1M/E2M40/80 ATEX special items

Item Number	Description	Qty	Part number
20	Mounting plate E1M/E2M40 (common part)	1	A36401008
21	Mounting plate E1M/E2M80 (common part)	1	A36501027
30	ATEX drive coupling (E1M/E2M40)	1	A21071113
30	ATEX drive coupling (E1M/E2M80)	1	A21071114
32	Motor spare E1M/E2M40 see Table 1e	1	A07128001
40	Fan adaptor	1	A21071116
43	Motor spare E1M/E2M80 see Table 1f	1	A07129001
44	1/4 inch BSP plug	1	A26002018
48	Fan (common part)	1	A22301003
111	M5 plain washer (per pump)	6	218980208
112	M5 full nut (per pump)	6	218980205
113	M4 x 12 cap hd screws (per pump)	3	218231289
114	M5 x 16 cap hd screws (per pump)	3	218231330
118	1/4 inch dowty seal	1	H02104002
220	ATEX elastic insert (spare)	1	A21071137
230	ATEX label (not shown)	1	A20001870
240	Motor key (E1M/E2M80 only)	1	A24301006

8 Spares kits and single spare items

Spares Kits available for the E1/E2M40 and E1/E2M80 series rotary vacuum pumps are listed in Table 29 and 30 below. Contents of individual kits are listed in Table 31 to 40.

The fine oil filter (Item Number A22304041) is available as a "single spare item".

Table 29 - E1/E2M40 spares kits

Description	Kit Item Number	Table Number
E1/E2M40 Clean and Overhaul Kit	A34401131	31
E1M40 Blade Kit	A34401050	32
E2M40 Blade Kit	A36401050	33
E1M40 Major Service Kit	A34401814	34
E2M40 Major Service Kit	A36401814	35

Table 30 - E1/E2M80 spares kits

Description	Kit Item Number	Table Number
E1/E2M80 Clean and Overhaul Kit	A34501131	36
E1M80 Blade Kit	A34501050	37
E2M80 Blade Kit	A36501050	38
E1M80 Major Service Kit	A34501814	39
E2M80 Major Service Kit	A36501814	40

8.1 E1/E2M40 clean and overhaul kit - A34401131

Table 31 - E1/E2M40 clean and overhaul kit items

Item	Description	Quantity	Code No.
30	Oil filter seal	1	A01403030
*36	Ballast piston	1	A19201007
50	Felt ballast filter	2	A22305041
59	Ballast valve	1	A25904601
69	Sight glass seal	1	A26501012
74	Distributor rubber	1	A27159415
76	HV exhaust rubber	1	A27159514
77	LV exhaust rubber	1	A27159515
78	Oil box gasket	1	A27159629
79	Body gasket	1	A27159428
80	Exhaust valve spacer	4	A27804004
85	Oil pump blade spring	1	A27102024
115	Dowty seal 1/8 inch BSP	2	H02104001
116	Dowty seal 1 inch BSP	1	H02104008
118	Dowty seal 1/4 inch BSP	1	H02104002
†	Dowty seal 3/4 inch BSP	1	H02104014
119	O-ring 5.6 mm i/d x 2.4 mm sect.	1	H02120027
120	O-ring 9.6 mm i/d x 2.4 mm sect	1	H02120031
121	O-ring 12.42 mm i/d x 1.78 mm sect. Fluoro	1	H02124119
122	O-ring 61.6 mm i/d x 2.4 mm sect	1	H02120057

Table 31 - E1/E2M40 clean and overhaul kit items (continued)

Item	Description	Quantity	Code No.
123	O-ring 64.5 mm i/d x 3.0 mm sect.	1	H02120082
124	O-ring 139.5 mm i/d x 3.0 mm sect.	1	H02120097
125	O-ring 7/16 inch i/d x 3/32 inch sect	1	H02125011
126	O-ring 3/4 inch i/d x 1/8 inch sect.	1	H02126020
127	O-ring 17/8 inch i/d x 3/16 inch sect.	2	H02125044
128	O-ring 3/16 inch i/d x 3/32 inch sect	2	H02125115
129	O-ring 5/16 inch i/d x 3/32 inch sect	5	H02125116
136	Uni-directional shaft seal 25 x 35 x 7 mm	2	H02109094
137	Weston oil seal 30 x 40 x 7 mm	1	H02109064
189	Waved washer	1	218990201
196	Exhaust warning label	1	A20001293

* E2M40 only.

† Required for pre-1988 "Fomblin" pump.

8.2 E1M40 blade kit - A34401050

Table 32 - E1M40 blade kit items

Item	Description	Quantity	Code No.
40	Oil pump blade	2	A20402418
85	Oil pump blade spring	1	A27102024
-	HV blade	2	A20402161

8.3 E2M40 blade kit - A36401050

Table 33 - E2M40 blade kit items

Item	Description	Quantity	Code No.
40	Oil pump blade	2	A20402418
85	Oil pump blade spring	1	A27102024
-	HV blade	2	A20402162
-	LV blade	2	A20402163

8.4 E1M40 major service kit - A34401814

Table 34 - E1M40 major service kit items

Item	Description	Quantity	Code No.
2	Oil filter assy.	1	A22305050
3	Inlet filter assy.	1	A22305035
30	Oil filter seal	1	A01403030
40	Oil pump blade	2	A20402418
-	HV blade	2	A20402161
43	Roller bearing	2	A20404011
49	Oil filter	1	A22304041

Table 34 - E1M40 major service kit items (continued)

Item	Description	Quantity	Code No.
50	Felt ballast filter	2	A22305041
55	Circlip	1	A22426004
59	Ballast valve	1	A25904601
69	Sight glass seal	1	A26501012
72	Compression spring	1	A27102013
74	Distributor rubber	1	A27159415
76	HV exhaust rubber	1	A27159514
78	Oil box gasket	1	A27159629
79	Body gasket	1	A27159428
80	Exhaust valve spacer	3	A27804004
83	Sight glass	1	A29201006
85	Oil pump blade spring	1	A27102024
115	Dowty seal 1/8 inch BSP	2	H02104001
116	Dowty seal 1 inch BSP	1	H02104008
118	Dowty seal 1/4 inch BSP	1	H02104002
*	Dowty seal 3/4 inch BSP	1	H02104014
119	O-ring 5.6 mm i/d x 2.4 mm sect.	1	H02120027
120	O-ring 9.6 mm i/d x 2.4 mm sect.	1	H02120031
121	O-ring 12.42 mm i/d x 1.78 mm sect. Fluoro	1	H02124119
122	O-ring 0616-24	1	H02120057
123	O-ring 0645-30	1	H02120082
124	O-ring 1395-30	1	H02120097
125	O-ring 7/16 inch i/d x 3/32 inch sect.	1	H02125011
126	O-ring 3/4 inch i/d x 1/8 inch sect.	1	H02126020
127	O-ring 17/8 inch i/d x 3/16 inch sect.	2	H02125044
128	O-ring 3/16 inch i/d x 3/32 inch sect.	2	H02125115
129	O-ring 5/16 inch i/d x 3/32 inch sect.	5	H02125116
136	Uni-directional shaft seal 25 x 35 x 7 mm	2	H02109094
137	Union oil seal 30 x 40 x 7 mm	1	H02109064
139	Flexible coupling element	1	A21071033
189	Waved washer	1	218990201

* Required for pre-1988 "Fomblin" pump.

8.5 E2M40 major service kit - A36401814

Table 35 - E2M40 major service kit items

Item	Description	Quantity	Code No.
2	Oil filter assy	1	A22305050
3	Inlet filter assy	1	A22305035
30	Oil filter seal	1	A01403030
36	Ballast piston	1	A19201007
40	Oil pump blade	2	A20402418
-	LV blade	2	A20402163
43	Roller bearing	2	A20404011

Table 35 - E2M40 major service kit items (continued)

Item	Description	Quantity	Code No.
-	HV blade	2	A20402162
49	Oil filter	1	A22304041
50	Felt ballast filter	2	A22305041
55	Circlip	1	A22426004
59	Ballast valve	1	A25904601
69	Sight glass seal	1	A26501012
72	Compression ring	1	A27102013
74	Distributor rubber	1	A7159415
76	HV exhaust rubber	1	A27159514
77	LV exhaust rubber	1	A27159515
78	Oil box gasket	1	A27159629
79	Body gasket	1	A27159428
80	Exhaust valve spacer	4	A27804004
83	Sight glass	1	A29201006
85	Oil pump blade spring	1	A27102024
115	Dowty seal 1/8 inch BSP	2	H02104001
116	Dowty seal 1 inch BSP	1	H02104008
118	Dowty seal 1/4 inch BSP	1	H02104002
*	Dowty seal 3/4 inch BSP	1	H02104014
119	O-ring 5.6 mm i/d x 2.4 mm sect.	1	H02120027
120	O-ring 9.6 mm i/d x 2.4 mm sect.	1	H02120031
121	O-ring 12.42 i/d x 1.78 sect. Viton	1	H02124119
122	O-ring 61.6 mm id x 2.4 mm sect.	1	H02120057
123	O-ring 64.5 mm i/d x 3.0 mm sect.	1	H02120082
124	O-ring 139.5 mm i/d x 3.0 mm sect.	1	H02120097
125	O-ring 7/16 inch i/d x 3/32 inch sect.	1	H02125011
126	O-ring 3/4 inch i/d x 1/8 inch sect.	1	H02126020
127	O-ring 17/8 inch i/d x 3/16 inch sect.	2	H02125044
128	O-ring 3/16 inch i/d x 3/32 inch sect.	2	H02125115
129	O-ring 5/16 inch i/d x 3/32 inch sect.	5	H02125116
136	Uni-directional shaft seal 25 x 35 x 7 mm	2	H02109094
137	Weston oil seal 30 x 40 x 7 mm	1	H02109064
139	Flexible coupling element	1	A21071033
189	Waved washer	1	218990201

* Required for pre-1988 "Fomblin" pump.

8.6 E1/E2M80 clean and overhaul kit - A34501131

Table 36 - E1/E2M80 clean and overhaul kit items

Item	Description	Quantity	Code No.
41	Oil filter seal	1	A01403030
* 48	Ballast piston	1	A19201007
66	Felt ballast filter	2	A22305041
69	Ballast valve	1	A25904601
79	Sight glass seal	1	A26501012
83	Distributor rubber	1	A27159415
84	LV exhaust rubber (old style)	1	A27159504
84	LV exhaust rubber (new style)	1	A27159541
86	HV exhaust rubber	1	A27159509
87	Oil box gasket	1	A27159618
89	Exhaust valve spacer	6	A27804004
94	Oil pump blade spring	1	A27102024
115	Dowty seal 1/8 inch BSP	2	H02104001
116	Dowty seal 1 inch BSP	1	H02104008
118	Dowty seal 1/4 inch BSP	1	H02104002
†	Dowty seal 3/4 inch BSP	1	H02104014
119	O-ring 6.5 mm i/d x 2.4 mm sect.	1	H02120027
120	O-ring 9.6 mm i/d x 2.4 mm sect.	1	H02120031
121	O-ring 12.42 i/d x 1.78 sect. Fluoro	1	H02124119
122	O-ring 61.6 mm i/d x 2.4 mm sect.	1	H02120057
123	O-ring 64.5 mm i/d x 3.0 mm sect.	1	H02120082
124	O-ring 159.5 mm i/d x 3.0 mm sect.	1	H02120101
125	O-ring 7/16 inch i/d x 3/32 inch sect.	1	H02125011
126	O-ring 3/4 inch i/d x 1/8 inch sect.	1	H02126020
127	O-ring 17/8 inch i/d x 3/16 inch sect.	2	H02125044
128	O-ring 3/8 inch i/d x 3/32 inch sect.	2	H02125115
129	O-ring 5/16 inch i/d x 3/32 inch sect.	5	H02125116
136	Uni-directional shaft seal 25 x 35 x 7 mm	2	H02109094
137	Weston oil seal 30 x 40 x 7 mm	1	H02109064
189	Waved washer	1	218990201
196	Exhaust warning label	1	A20001293

* E2M80 only

† Required for pre-1988 "Fomblin" pump.

8.7 E1M80 blade kit - A34501050

Table 37 - E1M80 blade kit items

Item	Description	Quantity	Code No.
52	Oil pump blade	2	A20402418
94	Oil pump blade spring	1	A27102024
-	HV blade	2	A20402164

8.8 E2M80 blade kit - A36501050

Table 38 - E2M80 blade kit items

Item	Description	Quantity	Code No.
34	Drive member	2	A36501024
52	Oil pump blade	2	A20402418
94	Oil pump blade spring	1	A27102024
-	LV blade	2	A20402165
-	HV blade	2	A20402164

8.9 E1M80 major service kit - A34501814

Table 39 - E1M80 major service kit items

Item	Description	Quantity	Code No.
2	Oil filter assy	1	A22305050
3	Inlet filter assy	1	A22305035
41	Oil filter seal	1	A01403030
-	HV blade	2	A20402164
52	Oil pump blade	2	A20402418
53	Roller bearings	2	A20404012
59	Filter	1	A22304041
64	Circlip	1	A22426004
66	Felt ballast filter	2	A22305041
69	Ballast valve	1	A25904601
79	Sight glass seal	1	A26501012
81	Spring	1	A27102013
83	Distributor rubber	1	A27159415
86	HV exhaust rubber	1	A27159509
87	Oil box gasket	1	A27159618
88	Body gasket	1	A27159428
89	Exhaust valve spacer	4	A27804004
91	Sight glass	1	A29201006
94	Oil pump blade spring	1	A27102024
115	Dowty seal 1/8 inch BSP	2	H02104001
116	Dowty seal 1 inch BSP	1	H02104008
118	Dowty seal 1/4 inch BSP	1	H02104002
*	Dowty seal 3/4 inch BSP	1	H02104014
119	O-ring 5.6 mm i/d x 2.4 mm sect.	1	H02120027
120	O-ring 9.6 mm i/d x 2.4 mm sect.	1	H02120031
121	O-ring 12.42 mm i/d x 1.78 mm sect. Fluoro	1	H02124119
122	O-ring 61.6 mm i/d x 2.4 mm sect.	1	H02120057
123	O-ring 64.5 mm i/d x 3.0 mm sect.	1	H02120082
124	O-ring 159.5 mm i/d x 3.0 mm sect.	1	H02120101
125	O-ring 7/16 inch i/d x 3/32 inch sect.	1	H02125011
126	O-ring 3/4 inch i/d x 1/8 inch sect.	1	H02126020
127	O-ring 17/8 inch i/d x 3/16 inch sect.	2	H02125044

Table 39 - E1M80 major service kit items (continued)

Item	Description	Quantity	Code No.
128	O-ring 3/8 inch i/d x 3/32 inch sect	2	H02125115
129	O-ring 5/16 inch i/d x 3/32 inch sect	5	H02125116
136	Uni-directional shaft seal 25 x 35 x 7 mm	2	H02109094
137	Weston oil seal 30 x 40 x 7 mm	1	H02109064
139	Flexible component	1	A21071033
189	Waved washer	1	218990201

* Required for pre-1988 "Fomblin" pump

8.10 E2M80 major service kit - A36501814

Table 40 - E2M80 major service kit items

Item	Description	Quantity	Code No.
2	Oil filter assy	1	A22305050
3	Inlet filter assy	1	A22305035
34	Drive member	2	A36501024
41	Oil filter seal	1	A01403030
48	Ballast piston	1	A19201007
-	LV blade	2	A20402165
-	HV blade	2	A20402164
52	Oil pump blade	2	A20402418
53	Roller bearings	2	A20404012
59	Filter	1	A22304041
64	Circlip	1	A22426004
66	Felt ballast filter	2	A22305041
69	Ballast valve	1	A25904601
79	Sight glass seal	1	A26501012
81	Spring	1	A27102013
83	Distributor rubber	1	A27159415
84	LV exhaust rubber (old style)	1	A27159504
84	LV exhaust rubber (new style)	1	A27159541
86	HV exhaust rubber	1	A27159509
87	Oil box gasket	1	A27159618
88	Body gasket	1	A27159428
89	Exhaust valve spacer	6	A27804004
91	Sight glass	1	A29201006
94	Oil pump blade spring	1	A27102024
115	Dowty seal 1/8 inch BSP	2	H02104001
116	Dowty seal 1 inch BSP	1	H02104008
118	Dowty seal 1/4 inch BSP	1	H02104002
*	Dowty seal 3/4 inch BSP	1	H02104014
119	O-ring 5.6 mm i/d x 2.4 mm sect	1	H02120027
120	O-ring 9.6 mm i/d x 2.4 mm sect.	1	H02120031
121	O-ring 12.42 mm i/d x 1.78 mm sect. Fluoro	1	H02124119
122	O-ring 61.6 mm i/d x 2.4 mm sect	1	H02120057

Table 40 - E2M80 major service kit items (continued)

Item	Description	Quantity	Code No.
123	O-ring 64.5 mm i/d x 3.6 mm sect.	1	H02120082
124	O-ring 159.5 mm i/d x 3.0 mm sect.	1	H02120101
125	O-ring 7/16 inch i/d x 3/32 inch sect	1	H02125011
126	O-ring 3/4 inch i/d x 1/8 inch sect.	1	H02126020
127	O-ring 1 7/8 inch i/d x 3/16 inch sect.	2	H02125044
128	O-ring 3/8 inch i/d x 3/32 inch sect.	2	H02125115
129	O-ring 5/16 inch i/d x 3/32 inch sect.	5	H02125116
136	Uni-directional shaft seal 25 x 35 x 7 mm	2	H02109094
137	Weston oil seal 30 x 40 x 7 mm	1	H02109064
139	Flexible component	1	A21071033
189	Waved washer	1	218990201

* Required for pre-1988 "Fomblin" pump.

Appendix A1 E2M40 LV stator sub-assembly modification

Gas ballast and filter tube assemblies have been modified (reference ECD 0322). Items 28 and 27 in Table A1 below supersede items 7 and 8 respectively in Table 13. This modification applies from E2M40 pump serial number 14812.

Table A1 - E2M40 LV stator sub-assembly items (ECD 0322)

Item	Description	Quantity	Code No.
5	Low Vac. rotor assy. (Spare)	1	A26401740
17	Interstage	1	A36401030
23	Low Vac. stator (Spare)	1	A36401712
24	End cover (Spare)	1	A36401713
27	Tube assy. (oil delivery)	1	A34401014
28	Tube assy. (ballast)	1	A34401015
61	Clamp (oil delivery line)	2	A25970035
63	Low Vac. exhaust baffle	1	A25970038
68	Low Vac. exh. plate	1	A25976007
77	Low Vac. exh. valve rubber	1	A27159515
80	Exh. valve spacer	1	A27804004
120	O-ring 9.6 mm i/d x 2.4 mm sect.	1	H02120031
129	O-ring 5/16 inch i/d x 3/32 inch sect.	4	H02125116
145	Spring pin \varnothing 1/4 inch x 1/2 inch lg.	1	211174099
149	Taper pin \varnothing 8 x 36 lg.	2	212192021
161	Pan hd. scr. M4 x 8 lg.	2	218042287
162	Pan hd. scr. SSM5 x 10 lg.	2	218221328
168	Soc hd. cap scr. M5 x 10 lg.	2	218091328
171	Soc hd. cap scr. M6 x 12 lg.	1	218091369
175	Soc hd. cap scr. M8 x 25 lg.	7	218091412
177	Soc hd. cap scr. M8 x 50 lg.	4	218091417
179	Soc hd. cap scr. M10 x 30 lg.	1	218091453
180	Soc set scr. cup pt. M10 x 12 lg.	1	218121449
229	Low Vac. blade	2	A20402624

Figure A1 - E2M40 LV stator sub-assembly (ECD 0322)

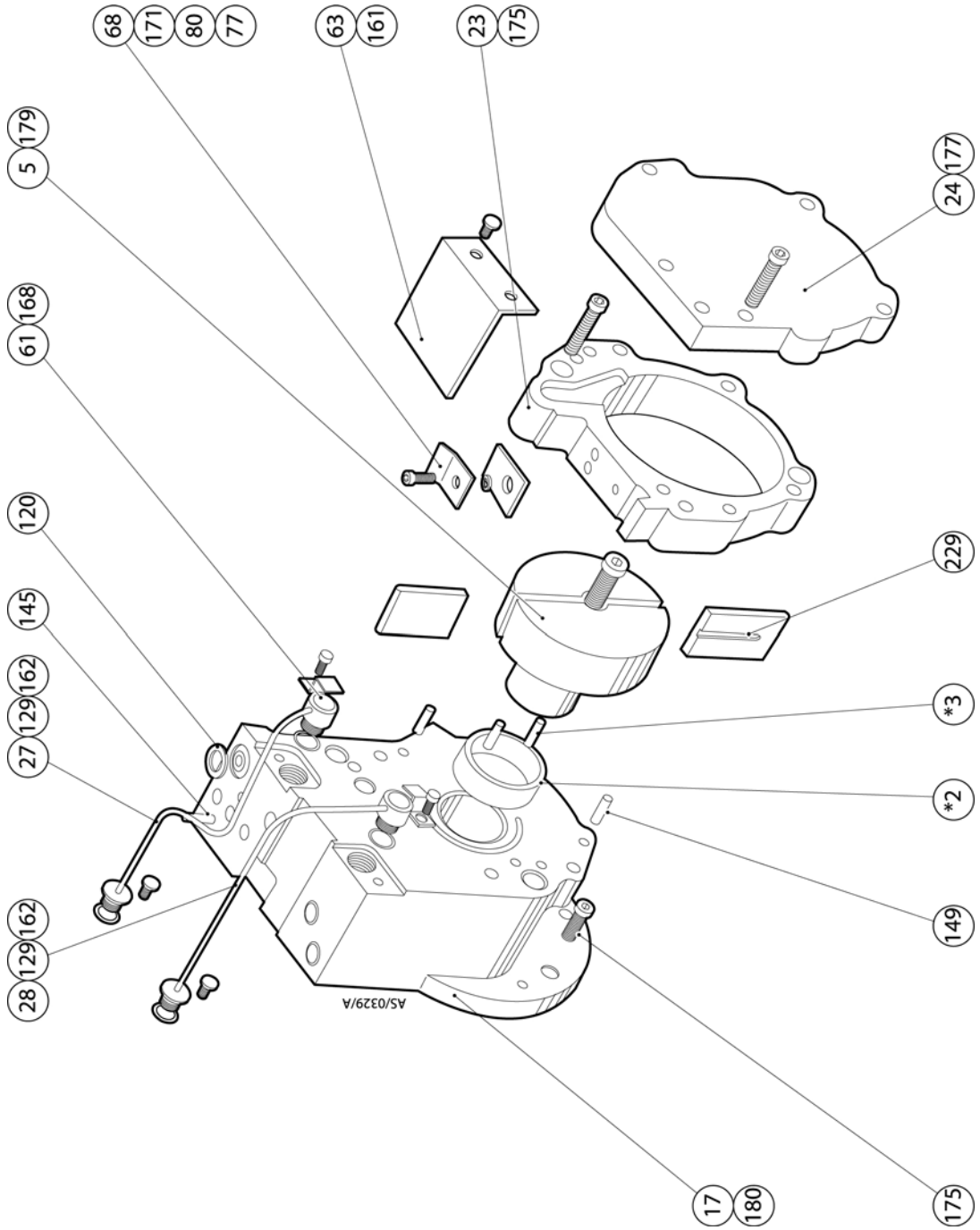

Appendix B 1 Exhaust warning label

This warning label item (196) shown in Figure B1 supersedes label item (191), and is fitted as standard to pumps from the following serial numbers onward:

E1M40 - Serial Number 2045

E2M40 - Serial Number 15605

E1M80 - Serial Number 1622

E2M80 - Serial Number 9409

Figure B1 - Exhaust warning label (ECDs 50924 and 51060)

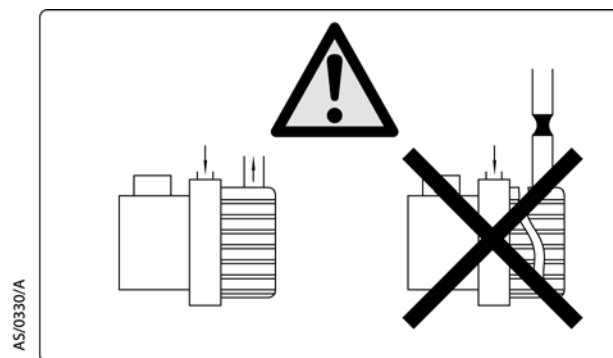

This label must be fitted to pumps of earlier manufacture when a clean and overhaul is performed. The label is included in the kit. The old label item (191) must be discarded from the pump.

This page has been intentionally left blank.