

PA810 Series

Digital Audio Baluns & Balun Panels

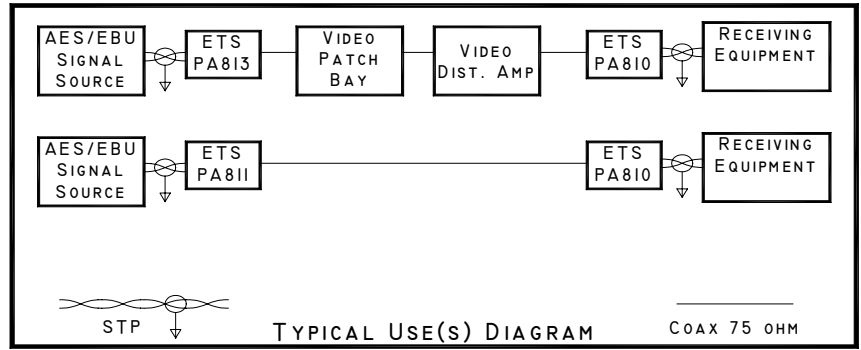

| Features/Advantages | Description | Applications |
|--|---|---|
| <ul style="list-style-type: none"> Converts AES/EBU digital audio between balanced 110Ω XLR and unbalanced 75Ω BNC Separate baluns, or rack-mountable panel versions Panel mount has monitor port for each channel Available in isolated versions*, to route signals via video patch bays, eliminate ground loops 10 dB pad available to attenuate signals to 1 V_{P-P} for compatibility with VDA and router equipment Metal cases, chassis Made in USA 100% tested | <p>ETS, long a leader in baluns for computer networks, applies our expertise in Balanced Line™ technology to the XLR to BNC Digital Audio Baluns (DAB) and DAB Panels. The PA810 Series of baluns and balun panels from ETS are designed to connect AES/EBU signals from XLR output equipment into standard 75Ω coax cabling systems. These baluns perform precise impedance matching and signal balancing, allowing AES/EBU signals to be transmitted with greater signal integrity and longer runs over coaxial cable than can be achieved with STP wiring. Isolated versions are available for VDA and router applications.</p> <p>The newest members of this family are the PA818-X Digital Audio Panels. Incorporating all of the functionality of our baluns in a convenient, 8 channel, single rack height unit, an isolated outputs and monitor ports for each channel are standard.</p> <p>The PA819 “Re-Balancer” balances signals into a real balanced line performance.</p> | <ul style="list-style-type: none"> Broadcast Control Rooms Recording Studios Post Production Facilities Satellite TV Facilities |

*NOTE: Versions of PA810, PA811 and PA813 available with isolation and with BNC male as custom order products.

| Specifications | | Product Ordering Information | |
|-------------------|-----------------------------------|---|--|
| Bandwidth | 20 kHz to 60 MHz (1 dB) | PA810 | AES/EBU Balun, FBNC to MXLR |
| Connectors | XLR to BNC | PA811 | AES/EBU Balun, FBNC to FXLR |
| Insertion Loss | < 0.15 dB | PA812 | AES/EBU Balun, FBNC to MXLR, 10dB [atten 1V _{P-P}] |
| Max Signal | 5V _{P-P} | PA813 | AES/EBU Balun, F-BNC to F-XLR, PAD to 1 V _{P-P} |
| Impedance Match | 75 Ω to 110Ω | PA818-F | AES/EBU Panel, (8) FXLR to FBNC, PAD to 1 V _{P-P} |
| Comm Mode Reject. | > 40 dB up to 40 MHz | PA818-H | AES/EBU Panel, (8): (4) as -F, (4) as -M |
| Distance | Up to 2500 ft - 75 ohm coax cable | PA818-FN | AES/EBU Panel, (8) FXLR to FBNC |
| Dimensions | Panels: 1 RU x 37mm deep | PA818-HN | AES/EBU Panel, (8): (4) as -FN, (4) as -M |
| | Baluns 20.3mm dia. x 89mm long | PA818-M | AES/EBU Panel, (8) MXLR to FBNC |
| Net Weight | Panel: 0.91 kg; Balun: 0.03 kg | PA819 | AES/EBU Rebalanced, MXLR to FXLR |
| | | * All PA818 panels have isolated outputs standard | |

© Copyright 2001-2009 Energy Transformation Systems

FatCat5 System panels and information outlets protected under US Patent Number 6,123,577. FatCat5, FatCat5 System, Chameleon Color Coding System, Balanced Star, Balanced Line, Monoline and Precision Wave are trademarks of Energy Transformation Systems. All other brand or product names are or may be trademarks of, and are used to identify, products or services of their respective owners.

Revised 10/15/2011



Ó ~ ÁOVUÁÚ!; â ~ & ÁeÁ
• çã^ [B] {

