

**G.703 E1**

**DIGITAL ACCESS UNITS**

SMALL PACK SERIES

E1

Fractional E1

Cascaded E1

Unframed E1

ACCESS UNITS

# **INSTALLATION and OPERATION MANUAL**

 **Megatel Industries Corp.**



# **Table of Contents**

---

<b>Chapter 1. Introduction</b> .....	1
1.0 Introduction .....	1
1.1 Functional Description .....	2
1.2 System Timing Considerations .....	5
1.3 Typical System Applications .....	10
1.4 E1 Signal Structure .....	12
1.5 Technical Specifications .....	14
<b>Chapter 2. Configuration and Operation</b> .....	19
2.0 Slide Switch Functions.....	19
2.1 DIP Switch Functions .....	19
2.2 Examples of DIP Switch Settings .....	29
2.3 G.703 Pack Factory Settings .....	34
2.4 Application Notes .....	35
<b>Chapter 3. Troubleshooting</b> .....	39
3.0 General .....	39
3.1 Connections .....	40
3.2 Configuration .....	40
3.3 Unit Testing .....	41
<b>Appendix A. Cable Definitions</b> .....	43
A.1 Pack Series DB25F Definition .....	43
A.2 RS-530 Cable Definition .....	44
A.3 V.35 Cable Definition .....	45
A.4 RS-449 Cable Definition .....	46
A.5 X.21 (DTE) Cable Definition .....	47
A.6 X.21 (DCE) Cable Definition .....	48
A.7 G.703 Port, RJ-45 Pin Assignment .....	49
A.8 G.703 E1 Cable (RJ-45) Pinout .....	49
A.9 Cable Ordering Information .....	50
Technical Inquiry Card .....	52

## ***Table of Contents***

---

### Revisions:

Page 51-53 added; Technical Inquiry Form; March 2, 2000

Page 15; added "Note for G703FE1-A" April 5, 2000

Page 54 added; Version 2.0 Addendum; September 25, 2000

Page 43; added pin 8 & 10 definitions to table; January 3, 2002

### 1.0 Introduction

The **G.703 E1 Pack Series** provides an economical digital access solution for E1 and Fractional E1 network services. A flexible selection of replaceable adapter cables provides a wide range of industry standard interfaces for both DTE or DCE devices, which may be linked to a **G.703 E1 Pack Series** at data rates (depending on model) of 64Kbps to 2048Kbps. User data is placed into the E1 frame, using only the required number of timeslots. Timeslot assignment is accomplished according to the Data Port speed and manual setting of DIP switches. The main E1 link may be clocked from the recovered receive clock (LBT), from the Data Port clock, or from an internal oscillator.

### Features

- LTU (Line Terminating Unit) built in unit.
- Single port access to E1 & Fractional E1 services.
- Interface conversion between G.703 E1 and RS-530, RS-449 (V.36), X.21, or V.35.
- Data rate: DIP selectable Sync Nx64Kbps - 2048Kbps. (**G703E1 & G703E1-U** excluded)
- Fully transparent signal conversion under unframed mode.
- Clock Regeneration from incoming HDB3 Data.
- Diagnostics Loopbacks both for G.703 (Recovery) and Data port sides.
- All 1's monitor.
- Decoded data in NRZ form.
- Cascadable, multiplexer function (**G703FE1-A** only)
- DC +9V input power.

### **1.1 Functional Description**

The **G.703 E1 Pack Series** are single port access units which, depending on model, provide E1 (**G703E1 & G703E1-U**), Fractional E1 (**G703FE1**), or Fractional cascade (multiplexing) E1 (**G703FE1-A**) access services. The **G.703E1 & G703FE1** operate on a line attenuation of up to 30 dB on twisted pair or coax cable, providing an approximate operating range of up to 1.5Km (using 22AWG wire). The **G.703FE1-A & G703E1-U** operate on a line attenuation of up to 43 dB on twisted pair or coax cable, providing an approximate operating range of up to 2Km (using 22AWG wire).

The **G.703 E1 Pack Series** supports local control and diagnostics via DIP Switch settings and a simple slide switch all located on the front panel. These features enable users to easily configure the unit, execute the loopback functions and monitor the network status locally.

The **G.703 E1 Pack Series** all operate from DC 9 volts, using a supplied AC adapter. The adapters are available with either a 110VAC (North America) or a 220VAC (Europe) input rating and with various plug configurations for world regions. The units are built in either a small compact aluminum or plastic case (**G703E1-U** uses a plastic case) that may be placed conveniently anywhere on a desktop or shelf.

The Small Pack Series sports four specific models with various functional differences as outlined below.

#### **Model: G703E1 (unframed E1)**

This model provides G.703 E1 access at the full unframed rate of 2.048Mbps only. The unit is housed in a metal case.

### **Model: G703FE1 (unframed / framed / fractional E1)**

This model provides fractional G.703 E1 access at rates of 64Kbps up to a maximum of 2.048Mbps in 64K multiples. The unit is housed in a metal case.

### **Model:G703FE1-A (cascaded E1)**

This model provides the same functions as the G703FE1 model with the addition of a cascade mode. In cascade mode, the unused timeslots may pass through the received E1 data transparently, allowing stacking of units in a multiplexer fashion. The unit is housed in a metal case.

### **Model: G703E1-U (unframed E1)**

This model provides identical functions as the G703E1 model in a slightly more compact and lighter weight plastic case. The unit operates in full unframed E1 (2.048Mbps) mode only.

The **G.703 E1 Pack Series** pack the data channel into user defined E1 link time slots (except for unframed models). The unused time slots may have IDLE code inserted (in fractional models) or have the receive side time slots' data inserted (in the cascade model).

The **G.703 E1 Pack Series** user data channel is RS-530 standard. Adapter cables provide interfaces for V.35, X.21, and RS-449. The desired interface may be set to either DCE or DTE mode via DIP switch settings, making it convenient to connect to a wide variety of terminal or communication equipment. For maximum flexibility, all framed models of the **G.703 E1 Pack Series** support data rates in multiples of 64Kbps up to 2.048Mbps and flexible time slot assignment, allowing the user to specify the selection of time slots carrying the data payload.

## **Chapter 1: Introduction**

---

The **G.703 E1 Pack Series** fully meet all of the E1 specifications including ITU recommendations G.703, G.704, G.706, G.732, and G.823.

The **G.703 E1 Pack Series** all have the ability to perform local loopback of either the G.703 signals or Data Port signals via a front panel slide switch. When used with a PCM transmission analyzer, the loopback function allows progressive BERT testing of the E1 link. Please refer to Chapter 3, Troubleshooting, for details.

Multiple clock source selection provides maximum flexibility in connecting both the E1 and user data interface. The E1 link may be clocked from the recovered E1 receive clock, from the user data port or from the internal oscillator. The next section will explain the timing modes available in detail.

### **1.2 System Timing Considerations**

The **G.703 E1 Pack Series** have the flexibility to meet the timing requirements of various system configurations. The timing mode for the E1 link and the user channel is selected by DIP switch settings.

The **G.703 E1 Pack Series** E1 link receive path always operates on the receive clock. The **G.703 E1 Pack Series** recovers the receive clock from the received E1 link data signal. The source of the **G.703 E1 Pack Series** E1 link transmit clock may be selected by the user. The following E1 link transmit timing modes and Data port transmit / receive modes are available:

- Recovery Timing
- Transparent Timing
- Data Port Timing
- Internal Oscillator

The following pages will explain each of the timing modes in more detail.

- **Recovery timing:**

In this mode, the **G.703 E1 Pack Series** E1 link transmit clock is locked to the recovered receive clock. This is usually the timing mode selected for network operation.

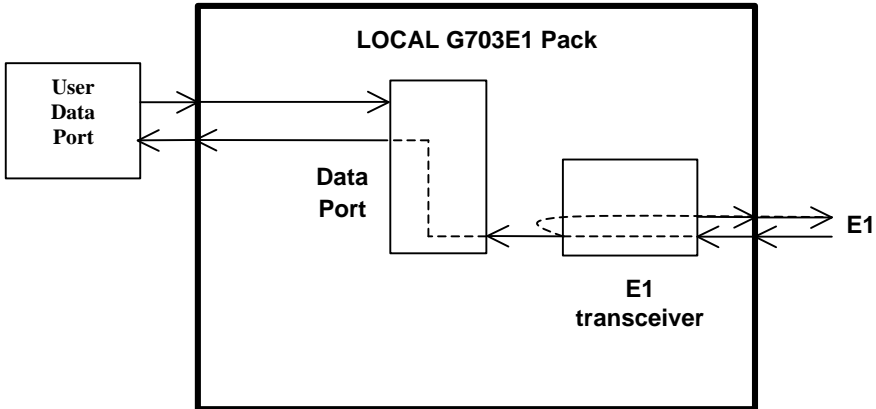

Figure 1-1: Recovery timing

When the user data port is in DTE mode, the E1 receive clock provides the clocking source for both the user data receive timing out the ETC pins and the user data transmit timing.

When the user data port is in DCE mode, the E1 receive clock provides the clocking source for both the user data receive timing out the RC/TC pins and the user data transmit timing.

## Chapter 1: Introduction

- **Internal timing:**

In this mode, the **G.703 E1 Pack Series** E1 link transmit clock is derived from the internal clock oscillator. This timing mode is necessary in point-to-point applications over leased line. In this case, one **G.703 E1 Pack Series** must be a timing source and use the internal oscillator, and the others must operate from the recovered clock.

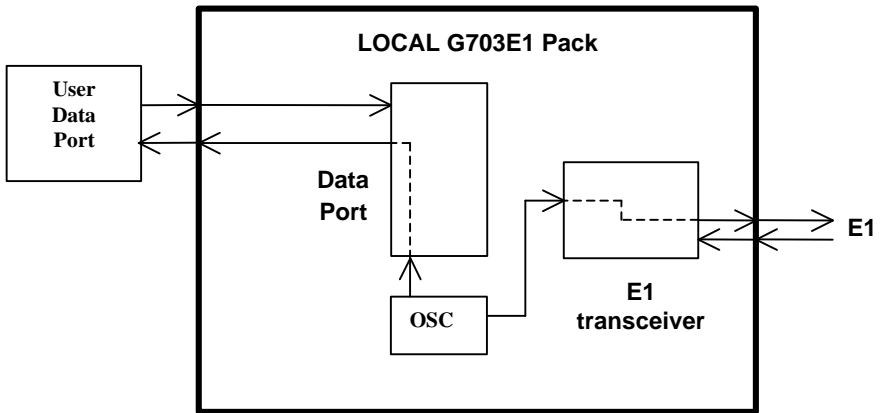

Figure 1-2: Internal Timing

When the user data port is in DTE mode, the internal oscillator provides the clocking source for both the user data receive timing out the ETC pins and the user data transmit timing.

When the user data port is in DCE mode, the internal oscillator provides the clocking source for both the user data receive timing out the RC/TC pins and the user data transmit timing.

- **Data Port timing:**

In this mode, the **G.703 E1 Pack Series** E1 link transmit clock is locked to the clock signal provided by the user Data Port connected to the data channel.

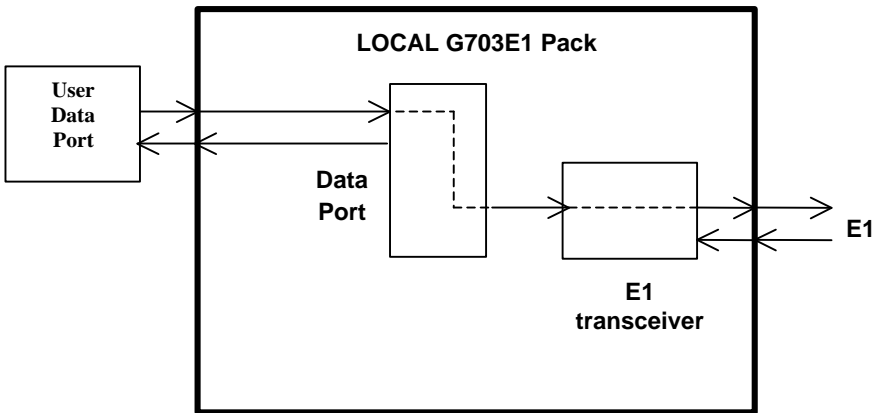

Figure 1-3: Data Port Timing

When the user data port is in DTE mode, the clock input from the RC pins provides the clocking source for both the user data receive timing out the ETC pins and the E1 transmit link.

When the user data port is in DCE mode, the clock input from the ETC pins provides the clocking source for both the user data receive timing out the RC/TC pins and the E1 transmit link.

- **Transparent timing:**

In this mode, the **G.703 E1 Pack Series** E1 link receive clock is the source for the data port receive clock while the E1 link transmit clock is locked to the clock signal provided by the user Data Port connected to the data channel.

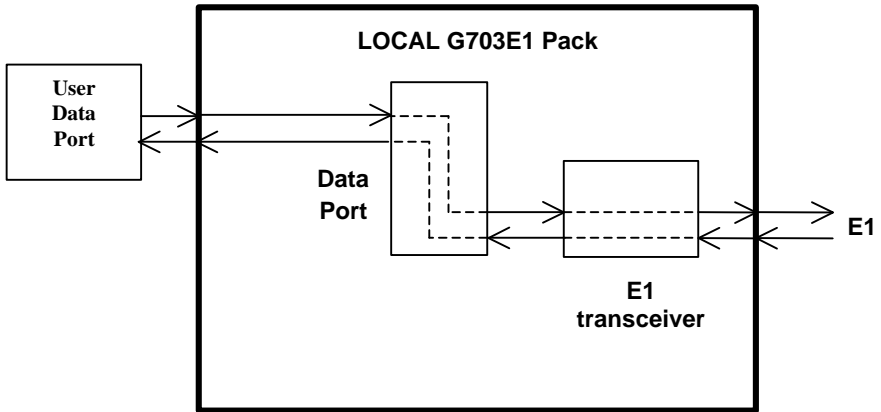

Figure 1-4: Transparent Timing

When the user data port is in DTE mode, the E1 receive clock provides the clocking source for the user data receive timing out the ETC pins. The user data transmit timing is input from the RC pins and provides the clock for the E1 transmit link.

When the user data port is in DCE mode, the E1 receive clock provides the clocking source for the user data receive timing out the RC/TC pins. The user data transmit timing is input from the ETC pins and provides the clock for the E1 transmit link.

## 1.3 Typical System Applications

### General

In a typical application (Figure 1-5), the **G.703 E1 Pack Series** is used in a point-to-point connection. The synchronous data channels of each router are connected over an E1 network connection.



Figure 1-5: Point-to-Point Application using **G703E1-U**.

Fractional E1 data service is based on the assumption that the user data rate is a fraction of the available E1 bandwidth, in multiples of 64K.



Figure 1-6: Fractional E1 Application using **G703FE1**.

In the next figure, the available E1 Time Slots are divided (Fractional E1) and cascaded (multiplexed). Various data interfaces may be employed in each **G.703 E1 Pack Series** to provide connections between hosts, clients or PBXs across the E1 transmission facility.

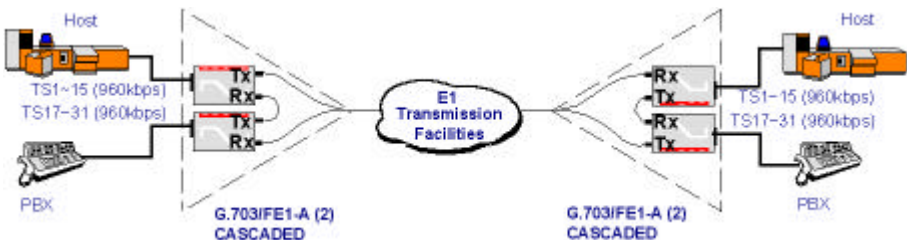

Figure 1-7: Cascaded application using G703FE1-A.

## **Chapter 1: Introduction**

---

In the previous example, the two hosts are connected with 960Kbps bandwidth using fifteen timeslots (TS1 ~ TS15). The PBXs are also using 960Kbps on fifteen timeslots (TS17 ~ TS31).

The framing mode used above is commonly referred to as PCM30. In this framing mode, timeslot zero is used for frame alignment (FAS) and timeslot 16 is used for signaling (CAS). Of the 32 timeslots available in the E1 frame, 30 are available for carrying the data payload. The next section will describe in more detail, the framing modes for E1 transmissions.

### **1.4 E1 signal structure**

The data transferred over the E1 line is organized into frames, with each E1 frame containing 256 bits. The 256 bits are comprised of a total of 32 time slots, each containing eight bits, that carry the data payload. The E1 line operates at a nominal rate of 2.048Mbps. If we divide that line rate by 32, the number of time slots, we find that the rate of each timeslot is 64Kbps

E1 transmission utilizes two main types of framing: Frame Alignment Signal (FAS) and Multi-Frame Alignment Signal (MFAS). Framing is necessary in order for equipment receiving the E1 signal to be able to identify and extract the individual channels. PCM-30 (CAS) transmission systems use MFAS framing along with the FAS framing. PCM-31 (CCS) transmission systems use only FAS framing.

#### **Frame Alignment Signal (FAS)**

The 2.048 Mbps frame consists of 32 individual time slots (numbered 0-31). As described previously, each time slot consists of an individual 64Kbps channel of data. In the FAS format, time slot 0 of every other frame is reserved for the frame alignment signal pattern. Alternate frames contain the FAS Distant Alarm indication bit and others bits reserved for national and international use.

#### **Multi-Frame Alignment Signal (MFAS)**

MFAS framing uses Channel Associated Signaling (CAS) to transmit A/B/C/D bit signaling information for each of 30 channels. This method uses the 32 time slot frame format with time slot 0 for the FAS and time slot 16 for the Multi-Frame Alignment Signal and the Channel Associated Signaling. This mode of framing is commonly used when connecting to PABX equipment.

## **Chapter 1: Introduction**

---

### **E1 line signal**

The basic E1 line signal is coded using the Alternate Mark Inversion (AMI) or HDB3 rule.

In AMI coding, “ones” are alternately transmitted as positive and negative pulses, whereas “zeros” are transmitted as a zero voltage level. AMI is not used in most 2.048Mbps transmissions because synchronization loss occurs during long strings of data zeros.

In HDB3 coding, a string of four consecutive zeros is replaced with a substitute string of pulses containing an intentional bipolar violation. The HDB3 code substitutions provide high pulse density so that the receiving equipment is able to maintain synchronization with the received signal.

### **E1 link line coding**

The **G703E1-U** model of the **G.703 E1 Pack Series** supports two E1 line codes:

- AMI coding.

- HDB3 coding.

All other models support only HDB3 coding.

### **E1 framing formats**

The **G.703 E1 Pack Series** supports three frame formats depending upon the model type:

Models: **G703E1** and **G703E1-U**

Unframed format only! (no FAS or CAS)

Models: **G703FE1** and **G703FE1-A**

Unframed format.

FAS (CCS, PCM-31) format.

MFAS (CAS, PCM-30) format.

### 1.5 Technical Specifications

#### E1 link

<b>Framing</b>	-Unframed/Framed (G703E1 & E1-U) -CCS (PCM31)/CAS (PCM30) -CRC4 ON/OFF
<b>Bit Rate</b>	2.048 Mbps
<b>Line Code</b>	-AMI (G703E1-U ONLY) -HDB3
<b>Line Impedance</b>	-75 ohms -120 ohms
<b>Relative Receive Level</b>	0 to -30dB (G703E1 & G703FE1) 0 to -43dB (G703FE1-A & G703E1-U)
<b>“Pulse” Amplitude</b>	-Nominal $2.37V \pm 10\%$ for 75 ohms -Nominal $3.00V \pm 10\%$ for 120 ohms
<b>“Zero” Amplitude</b>	$\pm 0.1V$
<b>Transmit Frequency Tracking</b>	
<b>Internal Timing</b>	$\pm 30$ ppm
<b>Loopback Timing</b>	$\pm 50$ ppm
<b>External Timing</b>	$\pm 100$ ppm
<b>Jitter Performance</b>	According to ITU G.823
<b>Complies With</b>	ITU G.703, G.704, G.706 and G.732
<b>Interface Connectors</b>	-shielded RJ-45 -BNC (x2)

## Chapter 1: Introduction

---

### User Data Port Channel

<b>Interface Types</b>	-RS-530 Standard, adapter cables for V.35, X.21, and RS-449
<b>I/F Connectors</b>	
<b>RS-530</b>	25 pin, D-type Female (on unit)
<b>Adapter Cables</b>	
<b>V.35 I/F</b>	34 pin, M-block Female or Male available
<b>X.21 I/F</b>	15 pin, D-type Female or Male available
<b>RS-449 I/F</b>	37 pin, D-type Female or Male available
<b>Line Code</b>	NRZ
<b>Data Rate</b>	<b>G703E1/E1-U:</b> 2048kbps unframed only <b>G703FE1/FE1-A:</b> n ´ 64kbps where n equal 1 to 31 in CCS (PCM31) and n equal 1 to 30 in CAS (PCM30)
<b>Clock Modes</b>	
<b>RECOVERY</b>	Receive and transmit clock (recovered) to the synchronous Data Port
<b>INT OSC</b>	Receive and transmit clock (internal oscillator) to the synchronous Data Port
<b>Transparent</b>	Receive clock to the synchronous, and transmit clock from the synchronous device
<b>Data Port</b>	Receive and transmit clock from the synchronous Data Port.
<b>Control Signals</b>	-CTS constantly ON -DSR constantly ON, except during test loops -DCD constantly ON, except during signal loss
<b>Time slot allocation</b>	Not Available in <i>G703E1</i> or <i>G703E1-U</i> User defined for <i>G703FE1</i> and <i>G703FE1-A</i>

**Note for G703FE1-A:**

CTS is internally connected to RTS.

DSR is internally connected to DTR.

## Chapter 1: Introduction

---

### LED indicators (G703E1/FE1/FE1-A metal case)

DTE	Green	Data Port set to DTE mode
DCE	Green	Data Port set to DCE mode
Rx Sig Loss	Red	E1 link signal loss
Tx Clk Loss	Red	E1 link Tx Clock loss
Alarm	Red	E1 link alarm, include: BPV error / CRC4 error / Frame slip / All ones(AIS) / Remote alarm
TD	Yellow	Transmit data (data port)
RD	Yellow	Receive data (data port)
Test	Red	Loopback active

### LED indicators (G703E1-U plastic case)

PWR	green	DC applied, power switch ON
Signal Loss	Red	E1 link signal loss
Timing Loss	Red	E1 link Tx Clock loss
TD	Yellow	Transmit data (data port)
RD	Yellow	Receive data (data port)
Test	Red	Loopback active

### Physical

	Metal Case type	Plastic Case type
Height:	30 mm	28 mm
Width:	99 mm	79 mm
Length: (excluding connectors)	170 mm	135 mm
Weight:	360 g	180 g

### Power supply

Voltage	DC 9V AC Adapter for 110VAC or 220VAC
Power consumption	less than 4 Watts (DC9V)

### Environment

Temperature	0-60C / 32-140F
Humidity	0 to 90% non-condensing

# Chapter 1: Introduction

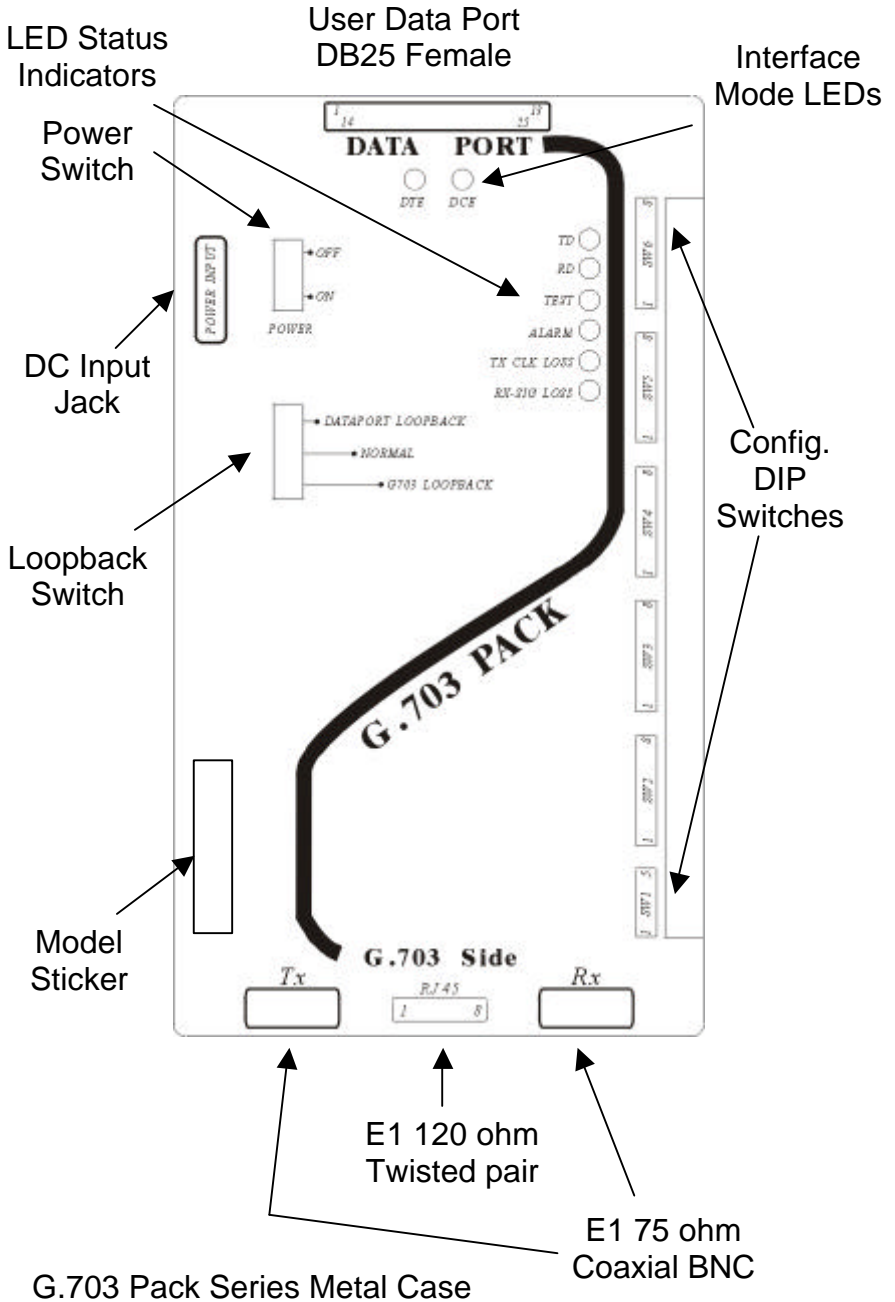

User Data Port  
DB25 Female

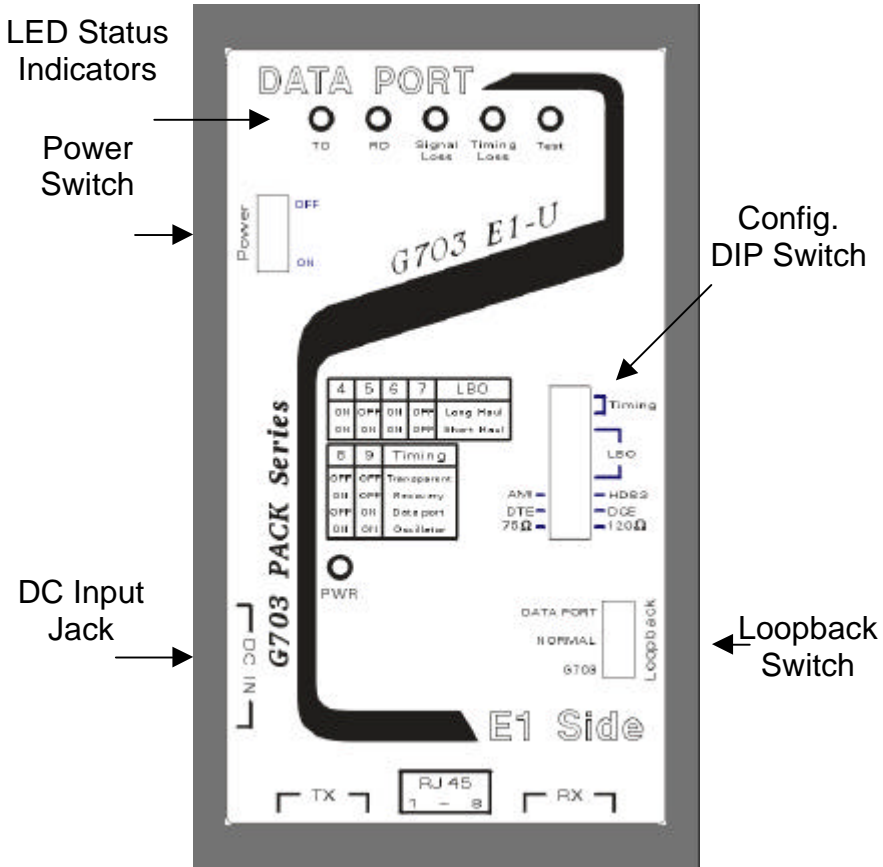

E1 120 ohm  
Twisted pair

E1 75 ohm  
Coaxial BNC

G.703 Pack Series Plastic Case

### 2.0 Slide Switch Functions

There are two slide switches on the unit. The **POWER** switch is a two position slide switch that controls the flow of DC power to the internal circuitry.

**NOTE:** Changes to the DIP switch settings are only recognized during CPU initialization. Use the **POWER** switch to cycle the DC off and then on. This will RESET the CPU and it will “read” the new DIP switch settings.

The other slide switch on the **G703E1 Small Pack Series** is for loopback operations. The middle position is for normal operation. The loopback positions provide an internal loopback on either the Data Port or the E1 Recovery Port.

### 2.1 DIP Switch Functions

Refer to the following tables for the functions of the DIP switches located along the side of the **G703E1 Small Pack Series**. The **G703FE1** and **G703FE1-A** provide a total of 31 DIP switches for timeslot setting. Each switch will activate or idle one 64Kbps timeslot (follow the  $N \times 64$  formula). On the **G703E1**, these switches have no function, as it operates in unframed mode only.

Fractional E1 uses only a fraction of the total available timeslots. For example, if you wish to translate only 192K from a 2048K E1 line, you only need to set three dip switches ( $192K \div 64K = 3$ ). You may select any three of the 32 timeslots, except TS0. TS0 is required for frame alignment when running in frame mode. If CAS (PCM30) framing is required, TS16 will also be unavailable for data transmission.

**NOTE:** If you are running under CAS mode, do not set DIP Sw4-1 (Time Slot number 16) on, the unit will enter “test mode”.

## Chapter 2: Configuration and Operation

Check carefully, this table is for the **G703E1** only.

SW. No.	DIP SW. STATUS					FUNCTIONS	Remarks	
SW1	1	2	3	4	5	E1 Line Impedance Setting		
	ON	ON	OFF	OFF	OFF	120 ohm line impedance		
	OFF	OFF	ON	ON	ON	75 ohm line impedance		
SW2	1	OFF				NA (Not Applicable)	The <b>G703E1</b> does not support fractional E1 services.	
		ON				NA		
	2	thru			8	NA		
SW3	1	thru			8	NA		
SW4	1	thru			8	NA		
SW5	1	thru			8	NA		
SW6	1	2				Rx/Tx timing source	(transparent)	
		OFF	OFF					Rx<Recovery,Tx<Data port
		OFF	ON					Rx/Tx<Data port
		ON	OFF					Rx/Tx<Recovery
		ON	ON					Rx/Tx<Internal Oscillator
		3	OFF					Rx Clk Polarity-Normal
			ON					Rx Clk Polarity-Inverted
		4	OFF					Tx Clk Polarity-Normal
			ON					Tx Clk Polarity-Inverted
		5	OFF					NA
		ON				NA		
	6	OFF				NA		
		ON				NA		
	7	OFF				NA		
		ON				NA		
	8	OFF				Data port is DCE		
		ON				Data port is DTE		

Table 2-1, **G703E1 Pack** DIP Switch Quick Reference.

Refer to the sticker on the unit and check the appendix for any updated information.

## Chapter 2: Configuration and Operation

Check carefully, this table is for the **G703FE1** only.

SW. No.	DIP SW. STATUS					FUNCTIONS	Remarks
SW1	1	2	3	4	5	E1 Line Impedance Setting	
	ON	ON	OFF	OFF	OFF	120 ohm line impedance	
	OFF	OFF	ON	ON	ON	75 ohm line impedance	
SW2	1	OFF				Unframed	
		ON				Framed	
	2	thru			8	Timeslot 1 thru 7	These switches are ignored if SW2-1 is set OFF (Unframed)
SW3	1	thru		8	Timeslot 8 thru 15		
SW4	1	thru		8	Timeslot 16 thru 23		
SW5	1	thru		8	Timeslot 24 thru 31		
SW6	1	2				Rx/Tx timing source	(transparent)
	OFF	OFF				Rx<Recovery, Tx<Data port	
	OFF	ON				Rx/Tx<Data port	
	ON	OFF				Rx/Tx<Recovery	
	ON	ON				Rx/Tx<Internal Oscillator	
	3	OFF				Rx Clk Polarity-Normal	
		ON				Rx Clk Polarity-Inverted	
	4	OFF				Tx Clk Polarity-Normal	
		ON				Tx Clk Polarity-Inverted	
	5	OFF				CRC4 Disabled	
	ON				CRC4 Enabled		
6	OFF				CAS/PCM30 mode		
	ON				CCS/PCM31 mode		
7	OFF				Unused Timeslot - MARK(FF)		
	ON				Unused Timeslot - FLAG(7E)		
8	OFF				Data port is DCE		
	ON				Data port is DTE		

Table 2-2, **G703FE1 Pack** DIP Switch Quick Reference.

Refer to the sticker on the unit and check the appendix for any updated information.

## Chapter 2: Configuration and Operation

Check carefully, this table is for the **G703FE1-A** only.

SW. No.	DIP SW. STATUS					FUNCTIONS	Remarks
SW1	1	2	3	4	5	E1 Line Impedance Setting	
	OFF	OFF	OFF	OFF	OFF	120 ohm line impedance	Note 1
	ON	ON	ON	ON	ON	75 ohm line impedance	
SW2	1	OFF ON				Unframe Frame	Note 2
	2	thru 8				Timeslot 1 thru 7	
SW3	1	thru 8				Timeslot 8 thru 15	Cascaded units MUST NOT be assigned identical or overlapping timeslots.
SW4	1	thru 8				Timeslot 16 thru 23	
SW5	1	thru 8				Timeslot 24 thru 31	
SW6	1	2				Rx/Tx timing source	Cannot be used while sw6-7 ON
	OFF		OFF			Rx<Recovery,Tx<Data port	
	OFF		ON			Rx/Tx<Data port	
	ON		OFF			Rx/Tx<Recovery	
	ON		ON			Rx/Tx<Internal Oscillator	
	3	OFF ON				Rx Clk Polarity-Normal Rx Clk Polarity-Inverted	
	4	OFF ON				Tx Clk Polarity-Normal Tx Clk Polarity-Inverted	
	5	OFF ON				CRC4 Disabled CRC4 Enabled	
	6	OFF ON				CAS/PCM30 mode CCS/PCM31 mode	
	7	OFF ON				Unused Timeslot - MARK(FF) Unused Timeslot - PASS THRU	
						When cascading, you <b>MUST</b> set this switch <b>ON</b>	
8	OFF ON				Data port is DCE Data port is DTE		

Note 1: Version prior to "0101" set termination as per G703FE1

Note 2: When set to Unframed, timeslot switches are ignored.

Table 2-3, **G703FE1-A Pack** DIP Switch Quick Reference.

Refer to the sticker on the unit and check the appendix for any updated information.

## Chapter 2: Configuration and Operation

Check carefully, this table is for the **G703E1-U** only.

SW. No.	Switch Status				FUNCTIONS	Remarks
1	OFF				120 ohm E1 line impedance	(RJ-45 connection)
	ON				75 ohm E1 line impedance	(BNC connection)
2	OFF				Data Port is DCE	(connect to DTE)
	ON				Data Port is DTE	(connect to DCE)
3	OFF				Line Code is HDB3	
	ON				Line Code is AMI	
	4	5	6	7	LBO	(Line Build Out)
	ON	OFF	ON	OFF	Long Haul	
	ON	ON	ON	OFF	Short Haul	
	8		9		Timing	
	OFF	OFF			Rx<Recovery, Tx<Data Port	(Transparent)
	ON	OFF			Rx/Tx<Recovery	
	OFF	ON			Rx/Tx<Data Port	
	ON	ON			Rx/Tx<Internal Oscillator	

Table 2-4, **G703E1-U Pack** DIP Switch Quick Reference.

Refer to the sticker on the unit and check the appendix for any updated information.

### G703E1 Pack Series DIP setting details (metal case).

<b>DIP SW2: SETTING FRAME/UNFRAME &amp; TIME SLOT 1-7</b>			
DIPSW NO.	SW STATE	FUNCTION	REMARK
1	OFF	UNFRAME MODE	NOTE 1,3
	ON	FRAME MODE	NOTE 2,3
2	OFF	TIME SLOT 1 IDLE	
	ON	TIME SLOT 1 ACTIVE	
3	OFF	TIME SLOT 2 IDLE	
	ON	TIME SLOT 2 ACTIVE	
4	OFF	TIME SLOT 3 IDLE	
	ON	TIME SLOT 3 ACTIVE	
5	OFF	TIME SLOT 4 IDLE	
	ON	TIME SLOT 4 ACTIVE	
6	OFF	TIME SLOT 5 IDLE	
	ON	TIME SLOT 5 ACTIVE	
7	OFF	TIME SLOT 6 IDLE	
	ON	TIME SLOT 6 ACTIVE	
8	OFF	TIME SLOT 7 IDLE	
	ON	TIME SLOT 7 ACTIVE	

Table 2-5, **G703FE1, FE1-A Pack** Setting Time Slot 1-7.

**NOTE 1:** In UNFRAMED MODE, the Clock Rate is FIXED at 2048KHz, therefore the settings of TIME SLOT 1-31 DIP settings do not matter.

**NOTE2:** In FRAMED MODE, the Clock Rate =  $64K \times N$  (N = NUMBER OF TIME SLOTS active).

**NOTE3:** In the **G703E1** unit, DIP SW2-SW5 are completely ignored.

## Chapter 2: Configuration and Operation

<b>DIP SW3: SETTING TIME SLOT 8-15</b>			
DIPSW NO.	SW STATE	FUNCTION	REMARK
1	OFF	TIME SLOT 8 IDLE	
	ON	TIME SLOT 8 ACTIVE	
2	OFF	TIME SLOT 9 IDLE	
	ON	TIME SLOT 9 ACTIVE	
3	OFF	TIME SLOT 10 IDLE	
	ON	TIME SLOT 10 ACTIVE	
4	OFF	TIME SLOT 11 IDLE	
	ON	TIME SLOT 11 ACTIVE	
5	OFF	TIME SLOT 12 IDLE	
	ON	TIME SLOT 12 ACTIVE	
6	OFF	TIME SLOT 13 IDLE	
	ON	TIME SLOT 13 ACTIVE	
7	OFF	TIME SLOT 14 IDLE	
	ON	TIME SLOT 14 ACTIVE	
8	OFF	TIME SLOT 15 IDLE	
	ON	TIME SLOT 15 ACTIVE	

Table 2-6, **G703FE1, FE1-A Pack** Setting Time Slot 8-15.

<b>DIP SW4: SETTING TIME SLOT 16-23</b>			
DIPSW NO.	SW STATE	FUNCTION	REMARK
1	OFF	TIME SLOT 16 IDLE	
	ON	TIME SLOT 16 ACTIVE	Note 1
2	OFF	TIME SLOT 17 IDLE	
	ON	TIME SLOT 17 ACTIVE	
3	OFF	TIME SLOT 18 IDLE	
	ON	TIME SLOT 18 ACTIVE	
4	OFF	TIME SLOT 19 IDLE	
	ON	TIME SLOT 19 ACTIVE	
5	OFF	TIME SLOT 20 IDLE	
	ON	TIME SLOT 20 ACTIVE	
6	OFF	TIME SLOT 21 IDLE	
	ON	TIME SLOT 21 ACTIVE	
7	OFF	TIME SLOT 22 IDLE	
	ON	TIME SLOT 22 ACTIVE	
8	OFF	TIME SLOT 23 IDLE	
	ON	TIME SLOT 23 ACTIVE	

Table 2-7, **G703FE1, FE1-A Pack** Setting Time Slot 16-23.

Note 1: If you are running under CAS mode, do not set DIP Sw4-1 on, the unit will enter "test mode".

## Chapter 2: Configuration and Operation

DIP SW5: SETTING TIME SLOT 24-31				
DIPSW NO.		SW STATE	FUNCTION	REMARK
1		OFF	TIME SLOT 24 IDLE	
		ON	TIME SLOT 24 ACTIVE	
2		OFF	TIME SLOT 25 IDLE	
		ON	TIME SLOT 25 ACTIVE	
3		OFF	TIME SLOT 26 IDLE	
		ON	TIME SLOT 26 ACTIVE	
4		OFF	TIME SLOT 27 IDLE	
		ON	TIME SLOT 27 ACTIVE	
5		OFF	TIME SLOT 28 IDLE	
		ON	TIME SLOT 28 ACTIVE	
6		OFF	TIME SLOT 29 IDLE	
		ON	TIME SLOT 29 ACTIVE	
7		OFF	TIME SLOT 30 IDLE	
		ON	TIME SLOT 30 ACTIVE	
8		OFF	TIME SLOT 31 IDLE	
		ON	TIME SLOT 31 ACTIVE	

Table 2-8, **G703FE1, FE1-A Pack** Setting Time Slot 24-31.

DIP SW6: FUNCTIONS					
DIP SW NO.		SW STATE		FUNCTION	REMARK
1	2	OFF	OFF	RX timing from recovery, TX timing from data port.	Reference
		OFF	ON	RX and TX timing all from data port.	DTE/DCE timing
		ON	OFF	RX and TX timing all from recovery.	
		ON	ON	RX and TX timing all from int. osc.	Source select Table 2-11.
3		OFF		RX clock polarity: NORMAL	
		ON		RX clock polarity: INVERT	
4		OFF		TX clock polarity: NORMAL	
		ON		TX clock polarity: INVERT	
5		OFF		CRC4 select: DISABLE	NO USE ON-G703E1
		ON		CRC4 select: ENABLE	NO USE ON-G703E1
6		OFF		SIGNALING mode select: CAS	NO USE ON-G703E1
		ON		SIGNALING mode select: CCS	NO USE ON-G703E1
7		OFF		IDLE code select: MARK(0xFF)	NO USE ON-G703E1
		ON		IDLE code select: FLAG(0x7E)	NO USE ON-G703E1
8		OFF		DATA PORT set to DCE	
		ON		DATA PORT set to DTE	

Table 2-9, **G703E1/FE1** DIP SW6 Functions.

## Chapter 2: Configuration and Operation

DIP SW6: FUNCTIONS					
DIP SW NO.		SW STATE		FUNCTION	COMMENT
1	2	OFF	OFF	RX timing from recovery, TX timing from data port.	Reference
		OFF	ON	RX and TX timing all from data port.	DTE/DCE timing
		ON	OFF	RX and TX timing all from recovery.	
		ON	ON	RX and TX timing all from int. osc.	Source select Table 2-11.
3	OFF	RX clock polarity: NORMAL			
	ON	RX clock polarity: INVERT			
4	OFF	TX clock polarity: NORMAL			
	ON	TX clock polarity: INVERT			
5	OFF	CRC4 select: DISABLE			
	ON	CRC4 select: ENABLE			
6	OFF	SIGNALING mode select: CAS			
	ON	SIGNALING mode select: CCS			
7	OFF	IDLE code select: MARK(0xFF)			Normal
	ON	IDLE code select: Pass Through			Cascade
8	OFF	DATA PORT set to DCE			
	ON	DATA PORT set to DTE			

Table 2-10, **G703FE1-A** DIP SW6 Functions.

DTE/DCE TIMING SOURCE SELECT TABLE					
DIP SW6 SETTING		DTE MODE		DCE MODE	
1	2	RX TIMING	TX TIMING	RX TIMING	TX TIMING
OFF	OFF	Recover from E1 port Output to ETC pins.	Source from data port. Input from RC pins.	Recover from E1 port. Output to RC/TC pins.	Source from data port. Input from ETC pins.
OFF	ON	Source from data port. Input from RC pins. Output to ETC pins.	Source from data port. Input from RC pins.	Source from data port. Input from ETC pins. Output to RC/TC pins.	Source from data port. Input from ETC pins.
ON	OFF	Recover from E1 port Output to ETC pins.	Source from E1 port.	Recover from E1 port. Output to RC/TC pins.	Source from E1 port.
ON	ON	From internal oscillator. Output to ETC pins.	From internal oscillator.	From internal oscillator. Output to RC/TC pins.	From internal oscillator.

Table 2-11, **G703E1 Pack Series** Timing Source.

## Chapter 2: Configuration and Operation

LED INDICATORS TABLE		
LED NAME	COLOR	INDICATION
DTE	GREEN	DATA PORT DTE MODE & POWER ON
DCE	GREEN	DATA PORT DCE MODE & POWER ON
TD	YELLOW	TRANSMIT DATA STATUS (ON:1/OFF:0/FLASH:CHANGE)
RD	YELLOW	RECEIVE DATA STATUS (ON:1/OFF:0/FLASH:CHANGE)
TEST	RED	LOOPBACK TEST (ON:TEST/OFF:NORMAL)
ALARM	RED	DETAIL SEE NEXT TABLE (ON:TEST/OFF:NORMAL)
TX CLOCK LOSS	RED	TRANSMIT CLOCK LOSS
RX SIGNAL LOSS	RED	RECEIVE SIGNAL LOSS

Table 2-12, **G703E1 Pack Series** LED Indicators.

The following table displays all of the possible alarm conditions that will result in lighting the alarm LED.

ALARM LED INDICATOR TABLE				
UNFRAME	FRAME MODE			
	CAS		CCS	
MODE	CRC4 OFF	CRC4 ON	CRC4 OFF	CRC4 ON
HDB3 CODE VIOLATION	HDB3 CODE VIOLATION	HDB3 CODE VIOLATION	HDB3 CODE VIOLATION	HDB3 CODE VIOLATION
RX DATA ALL ONES	RX REMOTE ALARM	RX REMOTE ALARM	RX REMOTE ALARM	RX REMOTE ALARM
	RECEIVE FAS LOSS	RECEIVE FAS LOSS	RECEIVE FAS LOSS	RECEIVE FAS LOSS
	RECEIVE CAS LOSS	RECEIVE CAS LOSS		CRC4 ERROR
	MF SYNC LOSS	MF SYNC LOSS		
		CRC4 ERROR		

Table 2-13, **G703E1 Pack Series** Alarm LED Indicator.

### 2.2 Examples of DIP Switch Settings

(**G703FE1-A** version 0101 or later)

Example 1: Set line impedance to 75 ohms.

DIP SW1				
1	2	3	4	5
ON	ON	ON	ON	ON

Example 2a: Set line impedance to 120 ohms.

DIP SW1				
1	2	3	4	5
OFF	OFF	OFF	OFF	OFF

Example 2b: Set line impedance to 120 ohms. (**G703E1 / FE1**)

DIP SW1				
1	2	3	4	5
		OFF	OFF	OFF
ON	ON			

## Chapter 2: Configuration and Operation

Example 3: UNFRAME mode, Clock rate fixed 2048Khz, DIPSW2-1 OFF. (**G703FE1** and **G703FE1-A** only)

Receive timing from E1 RX recovery, Transmit timing from data port, DIP SW6-1&2 OFF.

Data port set to DCE mode, DIP SW6-8 OFF.

Data port receive clock polarity: NORMAL, DIP SW6-3 OFF.

Data port transmit clock polarity: NORMAL, DIP SW6-4 OFF.

NOTE: X means “Don’t Care”

DIP SW2							
1	2	3	4	5	6	7	8
OF	X	X	X	X	X	X	X
	X	X	X	X	X	X	X

DIP SW3							
1	2	3	4	5	6	7	8
X	X	X	X	X	X	X	X
X	X	X	X	X	X	X	X

DIP SW4							
1	2	3	4	5	6	7	8
X	X	X	X	X	X	X	X
X	X	X	X	X	X	X	X

DIP SW5							
1	2	3	4	5	6	7	8
X	X	X	X	X	X	X	X
X	X	X	X	X	X	X	X

DIP SW6							
1	2	3	4	5	6	7	8
OF	OF	OF	OF	X	X	X	OF
				X	X	X	

## Chapter 2: Configuration and Operation

Example 4: FRAME & CAS mode (PCM30), DIP SW2-1 ON, DIP SW6-6 OFF. (**G703FE1** and **G703FE1-A** only)

Clock rate 64Khz insert in time slot 12, DIP SW3-5 ON.

CRC4 OFF, DIP SW6-5 OFF.

IDLE time slot code select: MARK(0xFF), DIP SW6-7 OFF.

Receive & Transmit timing from E1 RX recovery, DIP SW6-1 ON, DIP SW6-2 OFF.

Data port receive clock polarity: INVERT, DIP SW6-3 ON.

Data port transmit clock polarity: NORMAL, DIP SW6-4 OFF.

Data port set to DTE mode, DIP SW6-8 ON.

DIP SW2							
1	2	3	4	5	6	7	8
	OF	OF	OF	OF	OF	OF	OF
ON							

DIP SW3							
1	2	3	4	5	6	7	8
OF	OF	OF	OF		OF	OF	OF
				ON			

DIP SW4							
1	2	3	4	5	6	7	8
OF	OF	OF	OF	OF	OF	OF	OF

DIP SW5							
1	2	3	4	5	6	7	8
OF	OF	OF	OF	OF	OF	OF	OF

DIP SW6							
1	2	3	4	5	6	7	8
	OF		OF	OF	OF	OF	
ON		ON					ON

## Chapter 2: Configuration and Operation

Example 5: FRAME & CCS mode (PCM31), DIP SW2-1 ON, DIP SW6-6 ON.

Clock rate 1024Khz insert in time slot 1, 2, 3, 4, 6, 8, 10, 12, 16, 18, 24, 25, 26, 27, 30, 31. (**G703FE1** and **G703FE1-A** only)

CRC4 ON, DIP SW6-5 ON.

IDLE time slot code select: FLAG(0x7E), DIP SW6-7 ON.

Receive & Transmit timing from DATA PORT, DIP SW6-1 OFF, DIP SW6-2 ON.

Data port receive clock polarity: NORMAL, DIP SW6-3 OFF.

Data port transmit clock polarity: INVERT, DIP SW6-4 ON.

Data port set to DTE mode, DIP SW6-8 ON.

DIP SW2							
1	2	3	4	5	6	7	8
					OF		OF
ON	ON	ON	ON	ON		ON	

DIP SW3							
1	2	3	4	5	6	7	8
	OF		OF		OF	OF	OF
ON		ON		ON			

DIP SW4							
1	2	3	4	5	6	7	8
	OF		OF	OF	OF	OF	OF
ON		ON					

DIP SW5							
1	2	3	4	5	6	7	8
				OF	OF		
ON	ON	ON	ON			ON	ON

DIP SW6							
1	2	3	4	5	6	7	8
OF		OF				OF	
	ON		ON	ON	ON		ON

## Chapter 2: Configuration and Operation

Example 6: FRAME & CCS mode, DIP SW2-1 ON, DIP SW6-6 ON.

Clock rate 1984Khz insert in time slot 1~31, DIP SW3~DIP

SW6 all ON. (**G703FE1** and **G703FE1-A** only)

CRC4 OFF, DIP SW6-5 OFF.

IDLE time slot code select: MARK(0xFF), DIP SW6-7 OFF,  
(No idle time slot).

Receive & Transmit timing from E1 RX recovery, DIP SW6-1 ON, DIP SW6-2 OFF.

Data port receive clock polarity: INVERT, DIP SW6-3 ON.

Data port transmit clock polarity: INVERT, DIP SW6-4 ON.

Data port set to DTE mode, DIP SW6-8 ON.

DIP SW2							
1	2	3	4	5	6	7	8
ON	ON	ON	ON	ON	ON	ON	ON

DIP SW3							
1	2	3	4	5	6	7	8
ON	ON	ON	ON	ON	ON	ON	ON

DIP SW4							
1	2	3	4	5	6	7	8
ON	ON	ON	ON	ON	ON	ON	ON

DIP SW5							
1	2	3	4	5	6	7	8
ON	ON	ON	ON	ON	ON	ON	ON

DIP SW6							
1	2	3	4	5	6	7	8
	OF			OF		OF	
ON		ON	ON		ON		ON

## Chapter 2: Configuration and Operation

---

### 2.3 G.703 E1, FE1, FE1-A Pack factory settings.

DIP SW1				
1	2	3	4	5
ON	ON	ON	ON	ON

G703FE1-A version 0101 or later  
others set off,off,on,on,on

DIP SW2							
1	2	3	4	5	6	7	8
OF	OF	OF	OF	OF	OF	OF	OF

DIP SW3							
1	2	3	4	5	6	7	8
OF	OF	OF	OF	OF	OF	OF	OF

DIP SW4							
1	2	3	4	5	6	7	8
OF	OF	OF	OF	OF	OF	OF	OF

DIP SW5							
1	2	3	4	5	6	7	8
OF	OF	OF	OF	OF	OF	OF	OF

DIP SW6							
1	2	3	4	5	6	7	8
OF	OF	OF	OF	OF	OF	OF	OF

UNFRAME mode;  
Clock : 2048Kbps;  
Line Impedance : 75 ohms; (for **G703FE1-A** Model)  
RX timing from Recovery;  
TX timing from Data Port;  
TX/RX clock polarity : Normal;

### 2.4 Application Notes

**Fig 1 : G703E1 Point-to-Point application**

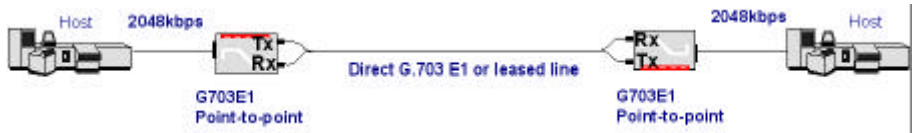

In the above point-to-point application, the **G703E1** packs are connected by a direct wire connection over 4 wire leased line. The G.703 E1 line is running in unframed mode at the full 2.048Mbps speed. Since the units are not connected to a network, one of the units must be set to be the timing source for the E1 link. Either one of the **G703E1**'s timing source (SW6-1&2) must be set to Data Port, Internal, or Recovery/Data port (transparent) timing. The other **G703E1** MUST then be set to Recovery for reliable operation.

**Fig 2 : G703E1 Point-to-Point network application**



In this point-to-point application, both **G703E1**'s are connected to an E1 transmission facility. This could be a series of PCM multiplexers than run through a very high-speed backbone connection. In any case, the transmission system is designed to be transparent. The clock source is from the network, therefore both **G703E1**'s timing source (SW6-1&2) should be set to Recovery. The frame mode and line code of each **G703E1** pack MUST match. In this example, the frame mode is unframed while the recommended line code is HDB3.

### Fig 3 : G703FE1 Point-to-Point network application



In the above point-to-point network application, both **G703FE1**'s timing source (SW6-1&2) should be set to Recovery. The frame modes (PCM30/PCM31) CRC, line code (AMI/HDB3), and timeslot assignment must match for each **G703FE1**. Unused timeslots may be set to MARK (0xff) or Flag (0x7e) depending upon setting of SW6-7.

### Fig 4 : G703FE1-A Cascade application

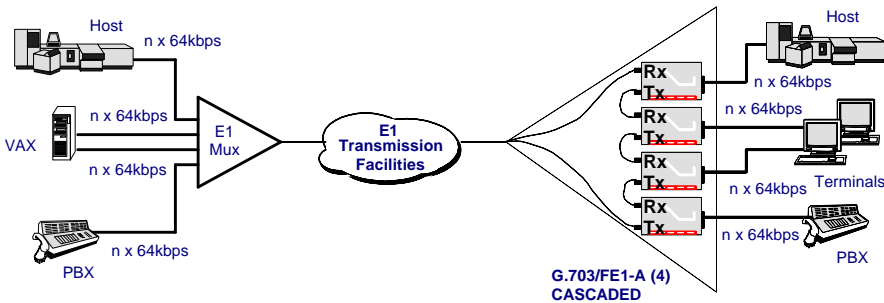

In the above figure, four **G703FE1-A**'s are cascaded. All access units' Dip Switches SW6-7 MUST be set to "ON" when cascaded. The timing source for all the **G703FE1-A**'s is from the network. Therefore, all timing sources should be set to "RECOVERY" (SW6-1&2; ON-OFF). The devices connected to the Data Port side (depicted on the right side of the figure), MUST derive their timing clock from the **G703FE1-A**'s recovered clock. Any combination of Data Port interface (RS-530, RS-449, V.35 and X.21) may be used. Timeslot selection is user configurable and must match the setup of the E1 Mux on the left side of the example.

### Fig 5 : G703FE1-A Cascade application

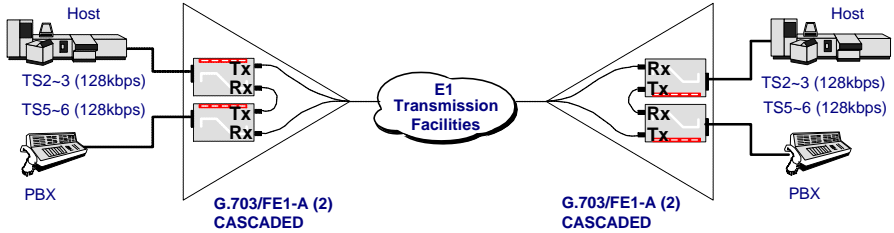

In this figure, the **G703FE1-A**'s are cascaded on both sides of the E1 transmission medium. The host-to-host connections are using the two timeslots 2 and 3 (SW2-3&4;ON-ON), for a combined bandwidth of 128kbps. If the cascaded pairs were directly connected, then one of the four **G703FE1-A**'s would have its timing source set either to the "DATA PORT" (SW6-1&2;OFF-ON) or to "Internal Oscillator" (SW6-1&2;ON-ON). The other three access units would be set to "RECOVERY" (SW6-1&2;ON-OFF). In the above network application, all units would be set to "Recovery" (SW6-1&2; ON-OFF). All access units' Dip Switches SW6-7 MUST be set to "ON" when cascading.

## **Chapter 2: Configuration and Operation**

---

### **3.0 General**

As in troubleshooting any type of computer, network, or communication problem, it is very important to follow a very logical procedure. During any troubleshooting session, the importance of taking notes cannot be overstated. It is very easy to forget connections or settings when troubleshooting a large network. Notes will help in logically checking all items and will also serve as a valuable aid in writing a system log or other report to your supervisor or your customer following successful completion of work. Notes also serve as important tools for future troubleshooting or for training of new personnel or just simply as a memory refresher.

When dealing with troubleshooting of first time installation problems, the best place to start is with double-checking of configuration settings and connections. It is very easy to misinterpret a DIP switch setting and cause the failure of a link. Initial configuration problems will also cause either immediate failure or inconsistent operations. Although the G703E1 Pack Series all comply with ITU G.703 recommendations, it is very important to understand the differences in terminology between different equipment manufactures. A thorough understanding of the settings and configuration of related equipment is mandatory when integrating many vendors' equipment.

Having the proper tools is also important in any troubleshooting endeavor. When troubleshooting E1 connections a transmission analyzer is an invaluable tool in isolating configuration, line or hardware problems. CTC Union's BTM-10 E1 Transmission Analyzer is an excellent choice. The unit is very portable, battery operated, with built-in keyboard and LCD display. The tester is designed to do BERT (Bit Error Rate) testing via E1 connection or via Data Port connection at speeds up to 2.048Mbps.

## **Chapter 3: Troubleshooting**

---

### 3.1 Connections

When checking for connection related problems, start by looking for physical defects in the connectors themselves. Check for broken or bent pins, corrosion and mis-wiring. Check cables for pinching that could indicate a broken or shorted wiring. For twisted pair wiring, confirm that a wire pair actually goes to the proper transmit or receive signal pairs. Build yourself an RJ-45 break-out-box from a pigtail converter. Loop back the pairs in the BOB and confirm continuity with a multi-meter.

### 3.2 Configuration

When physical connections have been confirmed, start looking for configuration problems. Confirm that the proper line code is being used. The PACK Series all support AMI and HDB3 line codes. In almost all instances, the line code will be HDB3. Confirm settings.

Framing errors can result if setting errors are made. Confirm the mode, whether unframed, framed PCM31 or framed PCM30 and whether CRC is enabled or not. If both sides of the E1 link are using different framing, there will be alarm indications.

Data errors may result if the timeslot assignments in fractional mode do not match. Check the settings carefully. For reduced monthly charges, a customer may only request a fraction of the E1 bandwidth. In this instance, an ISP may provide a fraction of the full 2.048Mbps bandwidth to a customer by utilizing Fractional E1. If only 512Kbps is requested, only eight (8) timeslots are required to carry the data payload. Carefully check the settings at the central site and confirm that the same eight timeslots are active on each end of the link.

## Chapter 3: Troubleshooting

---

### 3.3 Unit Testing

The examples given here all refer to use of CTC Union's BTM-10 E1 Transmission Analyzer. To test any of the PACK Series units alone, connect either an RJ-45 E1 cable or two coaxial cables between the Device Under Test (DUT) and the BTM-10 tester.



Figure 3-1: Test setup, E1 link

Configure the PACK Series unit for unframed, HDB3 line code, termination (75 ohm, if using coaxial connections or 120 ohm for twisted pair) and internal clock source. **Place the loopback switch on the G.703 side.** Configure the analyzer for E1 BERT, unframed, 75 ohm termination, HDB3 line code, external Tx and Rx clock, QRSS pattern and run "forever". Run the BERT. Confirm 2.048Mbps rate and no receive errors. If testing a remote link, inject a forced error and confirm loopback receipt of one error.

## Chapter 3: Troubleshooting

The BTM-10 may also be configured to do high-speed BERT from its data port. Alternatively, our HCT-6000 or HCT-BERT 2M analyzers may be configured to connect to the data port side of the DUT. In this setup, the unit and the link may be tested.

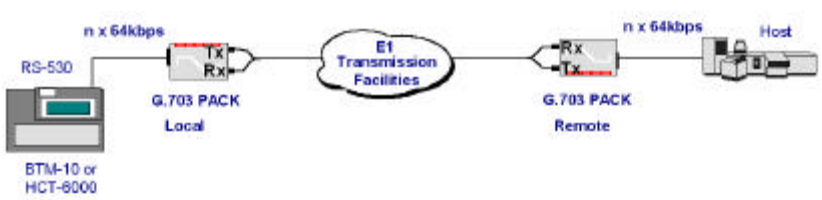

Figure 3-2: Link testing with BTM-10 or HCT-6000

In this example, the E1 units are connected to a network and derive their timing from the network (recovery). The tester is connected directly to the RS-530 interface of the data port. The clock on the tester is set to "external". Set up for BERT test and run a pattern to the data port. Place the loopback switch of the local unit to "Data Port". The receive data will be OK if the cabling and interface are functioning properly. Remove the local data port loopback. To test the local unit and the E1 link, place the remote unit in "G.703" loopback. Now the BERT pattern should be sent to the remote unit and looped back to the local side. To test end-to-end, apply a loop at the remote host using a loopback connector.

## Appendix A: Cable Definitions

### A.1 Pin Definitions of G703E1 Pack Series Data Port

G703E1 Pack Series DB25 Data Port PIN DEFINITIONS				
DB25 FEMALE PIN NUMBER	PIN NAME	DTE MODE	DCE MODE	COMMENT
1	SHIELD			
2	TD(A)	OUTPUT	INPUT	
3	RD(A)	INPUT	OUTPUT	
4	RTS(A)	*	*	NOTE 1
5	CTS(A)	*	*	NOTE 1
6	DSR(A)	*	*	NOTE 2
7	GROUND			
8	DCD(A)	NONE	OUTPUT	
9	RC(B)	INPUT	OUTPUT	
10	DCD(B)	NONE	OUTPUT	
11	ETC(B)	OUTPUT	INPUT	
12	TC(B)	INPUT	OUTPUT	
13	CTS(B)	*	*	NOTE 3
14	TD(B)	OUTPUT	INPUT	
15	TC(A)	INPUT	OUTPUT	
16	RD(B)	INPUT	OUTPUT	
17	RC(A)	INPUT	OUTPUT	
18	POWER IN			
19	RTS(B)	*	*	NOTE 3
20	DTR(A)	*	*	NOTE 2
22	DSR(B)	*	*	NOTE 4
23	DTR(B)	*	*	NOTE 4
24	ETC(A)	OUTPUT	INPUT	
25	GROUND			NOTE 5

Table A-1, Pin Definitions of **G703E1 Pack Series** Data Port

NOTE 1: RTS(A) AND CTS(A) INTERNALLY CONNECTED TOGETHER.

NOTE 2: DSR(A) AND DTR(A) INTERNALLY CONNECTED TOGETHER.

NOTE 3: RTS(B) AND CTS(B) INTERNALLY CONNECTED TOGETHER.

NOTE 4: DSR(B) AND DTR(B) INTERNALLY CONNECTED TOGETHER.

NOTE 5: This pin is used by the **HCT-6000** and **HCT-BERT/2M** to determine the presence of the **G703E1 Pack Series Access Unit**.

## Appendix A: Cable Definitions

---

### A.2

#### RS-530 Cables, 25 conductor round, 1 to 1, 100cm.

Male DB25 PIN		Male(or Female) DB25 PIN
1	<----->	1
2	<----->	2
3	<----->	3
4	<----->	4
5	<----->	5
6	<----->	6
7	<----->	7
8	<----->	8
9	<----->	9
10	<----->	10
11	<----->	11
12	<----->	12
13	<----->	13
14	<----->	14
15	<----->	15
16	<----->	16
17	<----->	17
18	<----->	18
19	<----->	19
20	<----->	20
21	<----->	21
22	<----->	22
23	<----->	23
24	<----->	24
25	<----->	25

## Appendix A: Cable Definitions

---

### A.3

### V.35 Cables, multi-conductor round, 100cm.

Male DB25		Male(or Female) MB34
PIN		PIN
2	<----->	P
14	<----->	S
3	<----->	R
16	<----->	T
4	<----->	C
5	<----->	D
6	<----->	E
20	<----->	H
8	<----->	F
24	<----->	U
11	<----->	W
15	<----->	Y
12	<----->	AA
17	<----->	V
9	<----->	X
1	<----->	A
7	<----->	B
22	<----->	J

NOTE: TWISTED PAIRS;

P,S  
R,T  
U,W  
Y,AA  
V,X

## Appendix A: Cable Definitions

---

### A.4

### RS-449 Cables, multi-conductor round, 100cm.

	Male DB25		Male(or Female) DB37
	PIN		PIN
	1	<----->	1
	7	<----->	19,20,37
(the following are all twisted pairs)			
	2	<----->	4
	14	<----->	22
	3	<----->	6
	16	<----->	24
	4	<----->	7
	19	<----->	25
	5	<----->	9
	13	<----->	27
	6	<----->	11
	22	<----->	29
	20	<----->	12
	23	<----->	30
	8	<----->	13
	10	<----->	31
	24	<----->	17
	11	<----->	35
	15	<----->	5
	12	<----->	23
	17	<----->	8
	9	<----->	26

## Appendix A: Cable Definitions

---

### A.5

### X.21 (DTE) Cables, multi-conductor round, 100cm.

Male DB25 PIN		Male(or Female) DB15 PIN
1	<----->	1
7	<----->	8
(the following are all twisted pairs)		
2	<----->	2
14	<----->	9
3	<----->	4
16	<----->	11
4	<----->	3
19	<----->	10
8	<----->	5
10	<----->	12
17	<----->	6
9	<----->	13

Note: This cable for DTE mode of Pack Series.

## Appendix A: Cable Definitions

---

### A.6 X.21 (DCE) Cables, multi-conductor round, 100cm.

Female DB25 PIN		Male(or Female) DB15 PIN
1	<----->	1
7	<----->	8
(the following are all twisted pairs)		
2	<----->	2
14	<----->	9
3	<----->	4
16	<----->	11
4	<----->	3
19	<----->	10
8	<----->	5
10	<----->	12
15,17	<----->	6
9,12	<----->	13

Note: This cable for DCE mode of Pack Series.

## Appendix A: Cable Definitions

---

### A.7 G.703 Port, RJ-45 Pin Assignment

- 1 NC
- 2 GND
- 3 Tx (-)
- 4 Rx (-)
- 5 Rx (+)
- 6 Tx (+)
- 7 GND
- 8 NC

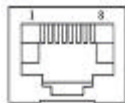

### A.8 G.703 E1 Cable (RJ-45) Pinout

RJ-45 Plug		RJ-45 Plug
PIN		PIN
1	<----->	1
2	<----->	2
3	<----->	4
4	<----->	3
5	<----->	6
6	<----->	5
7	<----->	7
8	<----->	8

## Appendix A: Cable Definitions

---

### A.9 Cable Ordering Information

MODEL	Description	Order No.
H6-EXT	DB25-M to DB25-F 1 meter (RS-530)	58-D2MD2F005
232CON-M	DB25-M to DB25-M 1 meter (RS-530)	58-D2MD2M000
V35CON2-M	DB25-M to MB34-M 1 meter (V.35)	58-D2MM3M001
V35CON2-F	DB25-M to MB34-F 1 meter (V.35)	58-D2MM3F001
449CON-M	DB25-M to DB37-M 1 meter (RS-449)	58-D2MD3M000
449CON-F	DB25-M to DB37-F 1 meter (RS-449)	58-D2MD3F000
X21-DTE/M	DB25-M to DB15-M 1 meter (X.21 DTE)	58-D1MD2M003
X21-DTE/F	DB25-M to DB15-F 1 meter (X.21 DTE)	58-D1FD2M003
X21-DCE/M	DB25-M to DB15-M 1 meter (X.21 DCE)	58-D1MD2M004
X21-DCE/F	DB25-M to DB15-F 1 meter (X.21 DCE)	58-D1FD2M004

# Megatel Industries

TEL: 610-239-8812

FAX: 610-239-8395

Attn : Technical Support Division

info@megatelindustries.com

From Company: \_\_\_\_\_

www.megatelindustries.com

Name: \_\_\_\_\_

Tel: ( ) \_\_\_\_\_

Fax:( ) \_\_\_\_\_

■ MODEL: • G703E1 • G703FE1 • G703FE1-A

■ ACTIVITY:As attached in DIP switch setting table

■ SYS CONFIGURATION:

■ Question:



# Technical Inquiry Form

MODEL No.: • G703E1 • G703FE1 • G703FE1-A

Please fill in the DIP switches configuration with '\*' marks into the following table. Send it to us by fax, and we will reply to you immediately.

SW NO.	DIP	FUNCTION	Your Setting		CTC Suggestion	
			ON	OFF	ON	OFF
SW1	1	E1 Line Impedance Setting				
	2	E1 Line Impedance Setting				
	3	E1 Line Impedance Setting				
	4	E1 Line Impedance Setting				
	5	E1 Line Impedance Setting				
SW2	1	Unframed/ framed				
	2	Timeslot 1				
	3	Timeslot 2				
	4	Timeslot 3				
	5	Timeslot 4				
	6	Timeslot 5				
	7	Timeslot 6				
	8	Timeslot 7				
SW3	1	Timeslot 8				
	2	Timeslot 9				
	3	Timeslot 10				
	4	Timeslot 11				
	5	Timeslot 12				
	6	Timeslot 13				
	7	Timeslot 14				
	8	Timeslot 15				
SW4	1	Timeslot 16				
	2	Timeslot 17				
	3	Timeslot 18				
	4	Timeslot 19				
	5	Timeslot 20				
	6	Timeslot 21				
	7	Timeslot 22				
	8	Timeslot 23				
SW5	1	Timeslot 24				
	2	Timeslot 25				
	3	Timeslot 26				
	4	Timeslot 27				
	5	Timeslot 28				
	6	Timeslot 29				
	7	Timeslot 30				
	8	Timeslot 31				
SW6	1	Rx/Tx timing source				
	2	Rx/Tx timing source				
	3	Rx Clk Polarity				
	4	Tx Clk Polarity				
	5	CRC4				
	6	CAS/PCM30 or CCS/PCM31				
	7	Unused Timeslot				
	8	Data port				

## Technical Inquiry Form

MODEL No.: • G703E1-U

Please describe your application environment and fill in the following DIP switch configuration table with ‘☒’ marks. Send to us by fax, and we will reply immediately.

DIP SW	FUNCTION	CUSTOMER SETTING		CTC SUGGESTION	
		ON	OFF	ON	OFF
1	Line impedance				
2	Data port				
3	Line code				
4	LBO				
5	LBO				
6	LBO				
7	LBO				
8	Timing source				
9	Timing source				

**Remarks:** Be sure the Loopback SW is in the “normal” position.  
**Your application :**

Commencing with the **G703 Pack Series** production in September 2000, the **G703/FE1** and **G703/FE1-A** have been upgraded to version V2.0. The V2.0 units may easily be identified by their off-white color cases.

The table below displays the “**G703/FE1 V2.0 DIP Switch Quick Reference**” table .The “**G703/FE1-A V2.0 DIP Switch Quick Reference**” table remains the same as the original “**G703/FE1-A DIP Switch Quick Reference**” table.

Check carefully, this table is for the **G703FE1 V2.0** only.

SW. No.	DIP SW. STATUS	FUNCTIONS	Remarks
SW1	1 2 3 4 5	E1 Line Impedance Setting	
	OFF OFF OFF OFF OFF	120 ohm line impedance	
	ON ON ON ON ON	75 ohm line impedance	
SW2	1 OFF	Unframed	These switches are ignored if SW2-1 is set OFF (Unframed)
	ON	Framed	
	2 thru 8	Timeslot 1 thru 7	
SW3	1 thru 8	Timeslot 8 thru 15	
SW4	1 thru 8	Timeslot 16 thru 23	
SW5	1 thru 8	Timeslot 24 thru 31	
SW6	1 2	Rx/Tx timing source	(transparent)
	OFF OFF	Rx<Recovery,Tx<Data port	
	OFF ON	Rx/Tx<Data port	
	ON OFF	Rx/Tx<Recovery	
	ON ON	Rx/Tx<Internal Oscillator	
	3 OFF	Rx Clk Polarity-Normal	
	ON	Rx Clk Polarity-Inverted	
	4 OFF	Tx Clk Polarity-Normal	
	ON	Tx Clk Polarity-Inverted	
	5 OFF	CRC4 Disabled	
ON	CRC4 Enabled		
6	OFF	CAS/PCM30 mode	
	ON	CCS/PCM31 mode	
7	OFF	Unused Timeslot - MARK(FF)	
	ON	Unused Timeslot – FLAG(7E)	
8	OFF	Data port is DCE	
	ON	Data port is DTE	

**Add. 1-1, G703FE1 V2.0 Pack DIP Switch Quick Reference.**



 **Megatel Industries Corp.**

**6 Crimson Drive  
Norristown, PA 19401, USA  
TEL: 610-239-8812 FAX: 610-239-8395  
[Http://www.megatelindustries.com](http://www.megatelindustries.com)  
[info@megatelindustries.com](mailto:info@megatelindustries.com)**