



**INSTALLATION INSTRUCTIONS  
POLARIS GENERAL  
ROOF  
PART # 88-1620A**

**IMPORTANT NOTICES**

**READ AND UNDERSTAND THESE INSTRUCTIONS COMPLETELY BEFORE INSTALLATION TO AVOID INJURY TO YOURSELF, DAMAGE TO THE VEHICLE OR ACCESSORY.**

- For proper installation, **TWO** people are required.
- Torque specifications must be followed when tightening bolts. Over-tightening any and/or all screws will cause cracks around mounting holes which is not covered by any warranty.
  - As specified on carton label, once protective film on shields is removed, product cannot be returned.
- As specified on carton label, damage caused by packaging staples is not covered by warranty. All staples must be removed prior to removing product from carton.
- Failure to follow these installation instructions completely may void any warrantable components and result in product damage or personal injury.
- Do not use Loctite or any other similar fastener adhesive. These types of products react to plastics and cause cracking. Not covered by any warranty.
- Our windshields are made from the highest quality material providing optimum transparency and clarity. Blurriness and/or extrusion marks may or may not appear when looking through windshield from a wide, side-angle. This is normal for all extruded clear plastic materials.
- The application of improper cleaners, abrasive and/or dirty cleaning towels can severely damage the product. Failure to follow cleaning recommendation (provided herewith) may void any warrantable components.

**DEALER**

These instructions contain important information for future reference and must be given to the customer at time of purchase or upon completion of installation.

**Parts List** (parts available with kit only and not available separately)

ITEM	PART NAME	DESCRIPTION	QTY
A	Roof (front part)	CNC roof made of 3/16" thick high density polyethylene	1
B	Roof (rear part)	CNC roof made of 3/16" thick high density polyethylene	1
C	Co-extruded bulb seal	Includes: 114" Co-extruded bulb seal <b>[end user to cut to exact length]</b>	1
INSTRUCTION BAG	D	Foam cushion Included: 48" of 1" x 1/16" self-adhesive foam cushion <b>[end user to cut to exact length]</b>	1
	E	Nuts & bolts Includes: 6 metal plate hooks, 21 philips truss screws M6 x 20, 30 plastic washers M6, 9 locknuts M6 and 2 well-nuts M6	1
	F	Wet-nap Includes: wet-nap	2

**1. Installation**

- a) Temporarily remove the OEM steel plate (4 screws) located under the OEM front visor as shown below. Keep all parts; some will be reinstalled during roof installation.

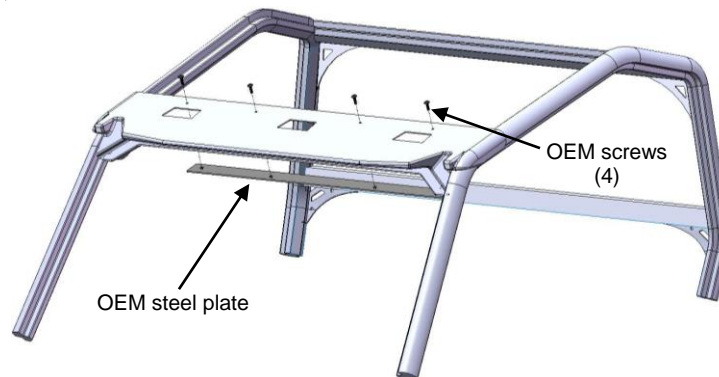

# IMPORTANT NOTICES

**Over-tightening any and/or all screws will cause cracks around mounting holes which is not covered by any warranty.**

- b) Apply the self-adhesive foam cushion (Item D) to the front side of the rear roof (Item B) as shown. For proper installation, the roof must be free of any dust or any other contamination. Using a pen, screwdriver or any other similar pointy tool, pierce through the foam cushion using the rear roof mounting holes as guides (9 locations).

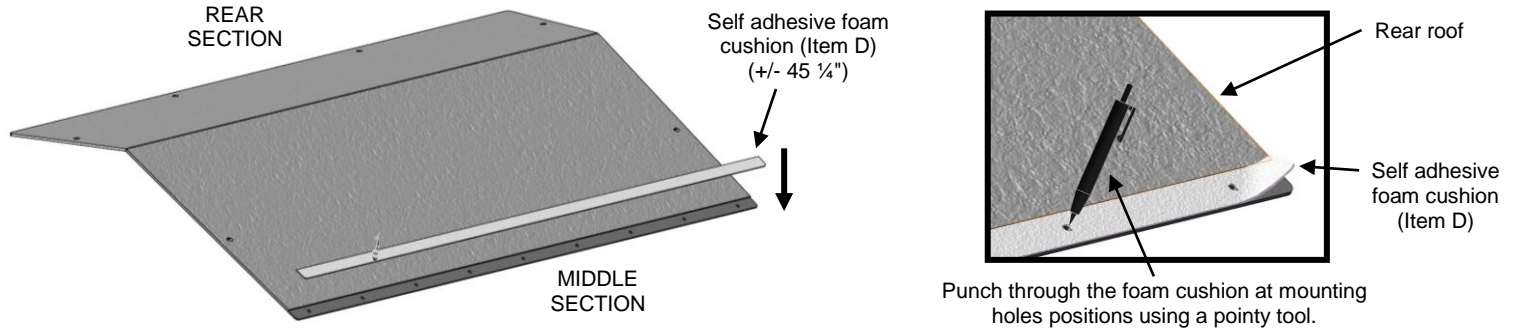

- c) Assemble the front and the rear roof together using supplied hardware (Item E) as shown below.

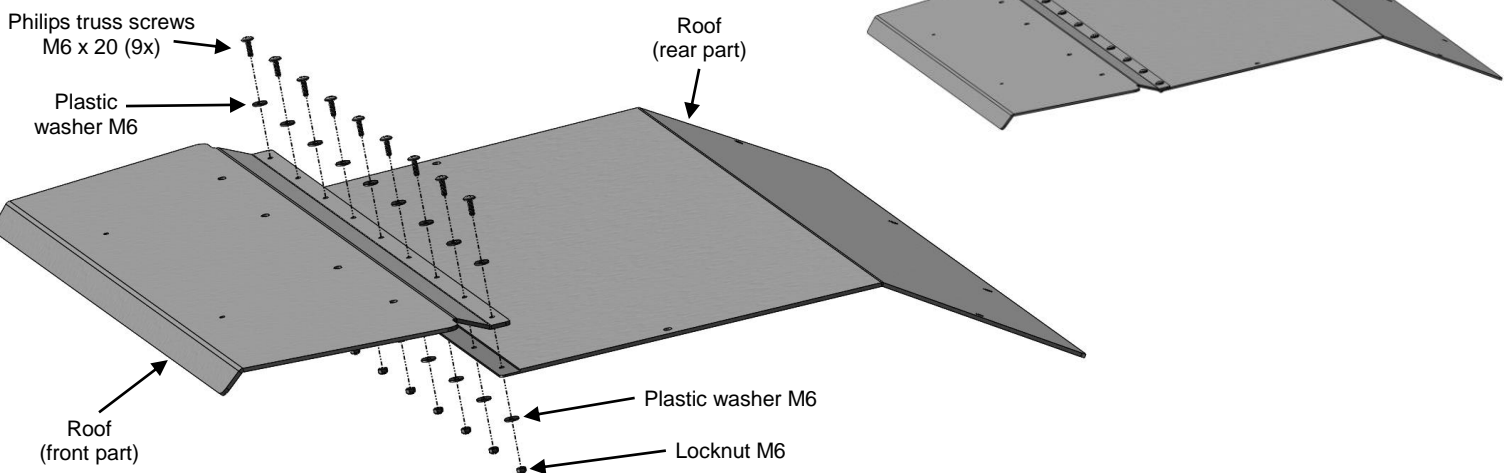

- d) Find a clean flat area where you can safely lay down the assembled roof and apply the co-extruded bulb seal (Item C) as shown below using manual pressure to ensure good adhesion and cut any excess.

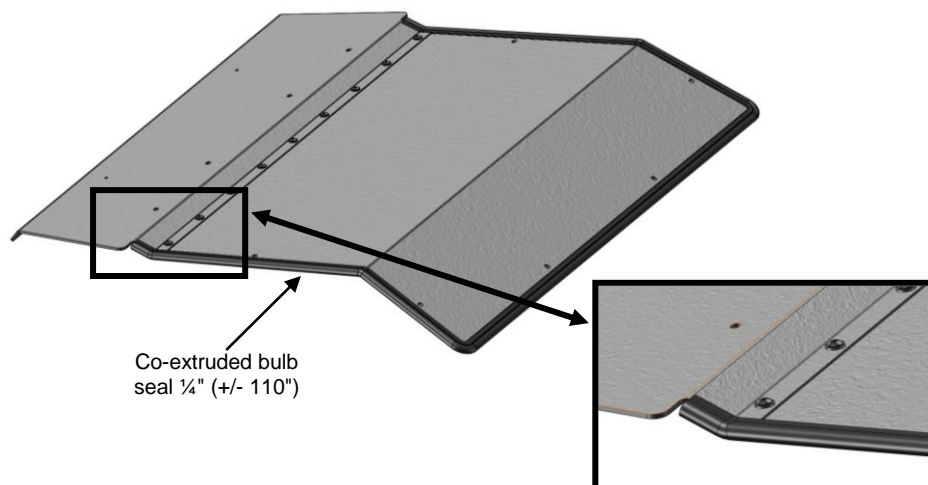

# IMPORTANT NOTICES

**Over-tightening any and/or all screws will cause cracks around mounting holes which is not covered by any warranty.**

- e) Temporarily install the roof to the vehicle using supplied hardware (Item E) as shown below. Adjust the position of the roof and (as per fig. E2 & E3) drill 2 mounting holes of 1/4" diameter through the first layer of the OEM front visor using the front roof mounting holes as guides. **Caution: only the first layer of the OEM front visor must be drilled.**

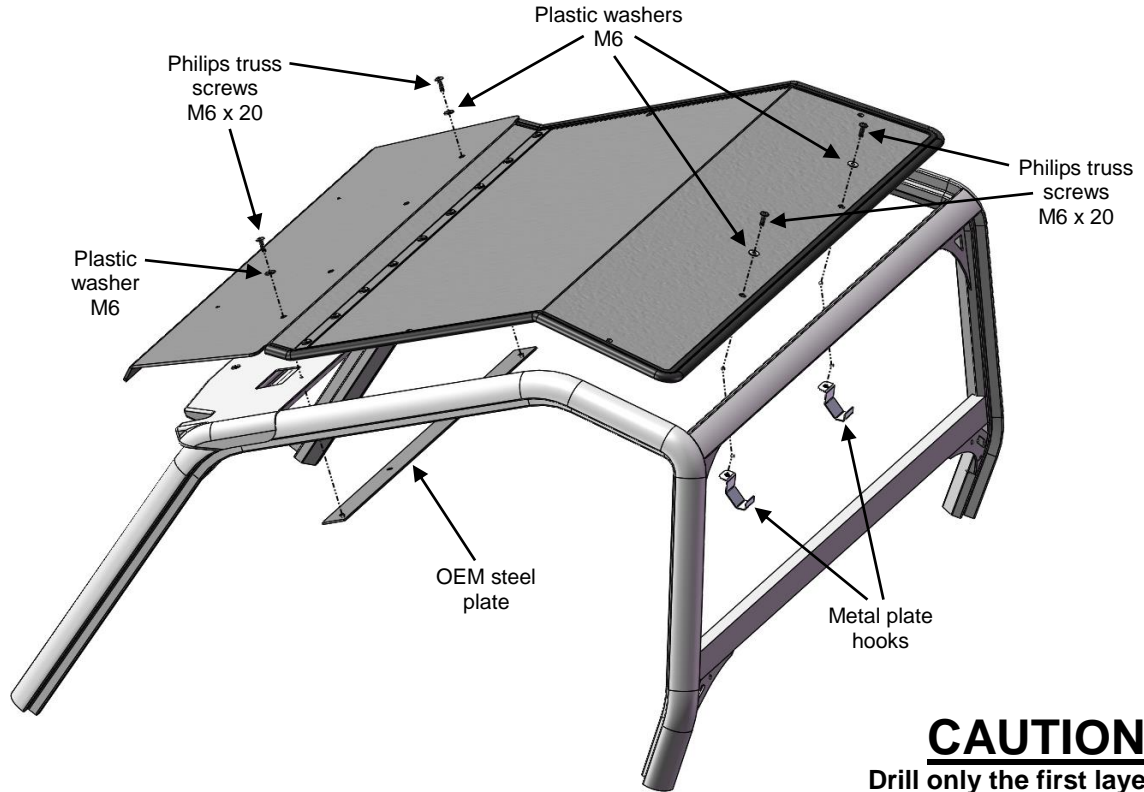

**CAUTION!!**  
**Drill only the first layer of the OEM front visor**

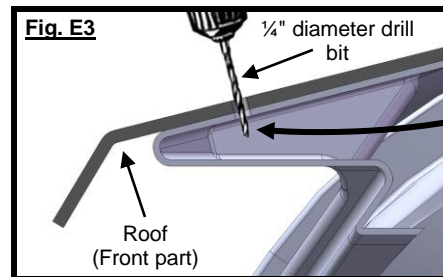
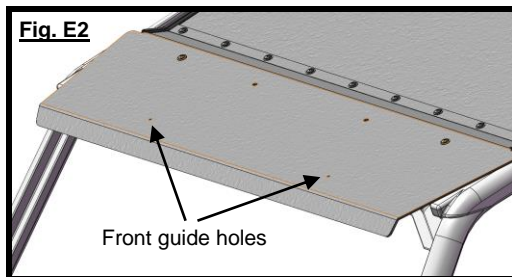

- f) Before completing the roof installation, the 2 holes that have been drilled on the OEM front visor at the previous step need to be enlarged to a diameter of 1/2". To achieve this operation, the roof must be temporarily removed.

**Caution: only the first layer of the OEM front visor must be drilled.**

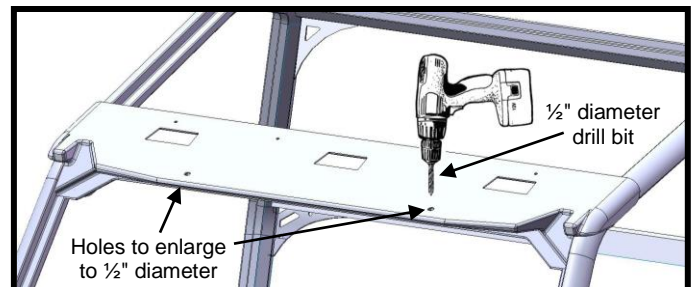

# IMPORTANT NOTICES

**Over-tightening any and/or all screws will cause cracks around mounting holes which is not covered by any warranty.**

- g) Install the roof to the vehicle using supplied hardware (Item E) as shown below. Adjust the position of the roof and tighten.

**Caution: over tightening any hardware could cause irreversible damage to the roof.**

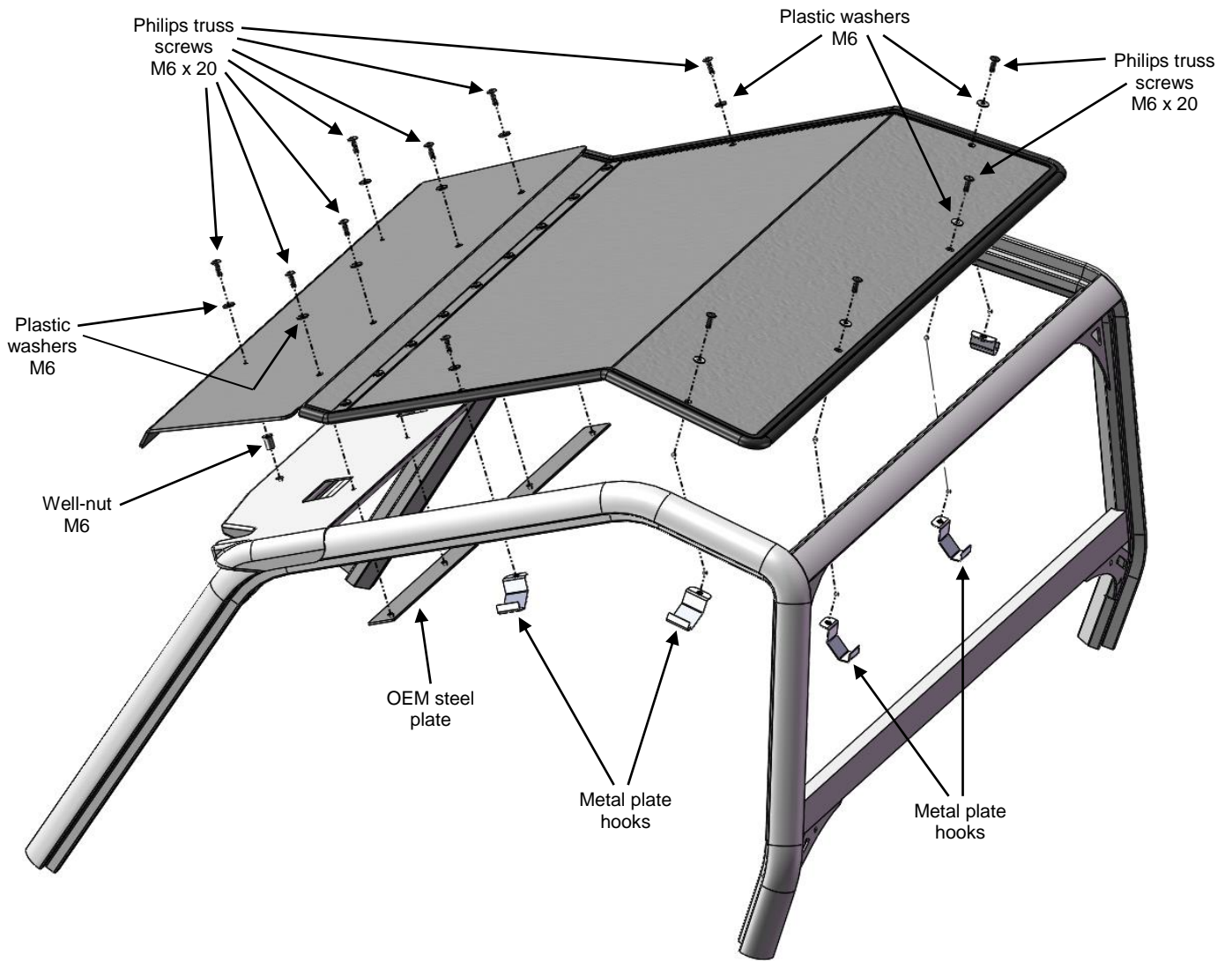

## 2. Maintenance and Care

Tighten all hardware after first use and periodically thereafter.