

# RK-FR-H520-HL

Honda Foreman/ Rubicon 520 & Rancher 420 ATV (Non-Power Steering)  
Radiator Relocation Kit



# HL

**HIGHLIFTER**

**SEIZMIK™**

  
**FALCON RIDGE**

 **SNORKEL  
YOUR ATV**

**SYSTEM 3**  
OFF-ROAD  
Traction. Strength. Style.

**EPI**  
PERFORMANCE



[sales@highlifter.com](mailto:sales@highlifter.com)



800-699-0947 | 8:00am - 5:00pm CST



7455 Atkinson Drive, Shreveport, LA 71129



[www.highlifter.com](http://www.highlifter.com)

Parts Available For These Popular Brands and Others

**POLARIS**

**can-am**



**HONDA**

**Kawasaki**



**YAMAHA**

## READ BEFORE INSTALLATION

### WARNING:

Be advised that there are certain hazards of burning or scalding, that are created by installing radiators with potentially boiling hot fluids in locations other than those selected by the ATV manufacturer. By relocating the radiator, the customer and installer indicate that they understand and accept all risks and liability that are or may be created by moving the vehicles radiator to a non standard location.

The purchaser and installer hereby release High Lifter, it's officers, and employees from any and all potential responsibility that may arise from installation of this radiator relocation kit. It is also the duty of the installer or purchaser to inform the rider or next owners of these potential hazards.

Upon completion verify all hoses and wires are not touching or rubbing the plastic. Vibration **WILL** rub a hole in the lines very quickly. Zip-tie all lines and hoses securely.

## PARTS DIAGRAM

**NOTICE: SOME PARTS AND PHOTOS WILL VARY FROM ONE MODEL TO ANOTHER.**

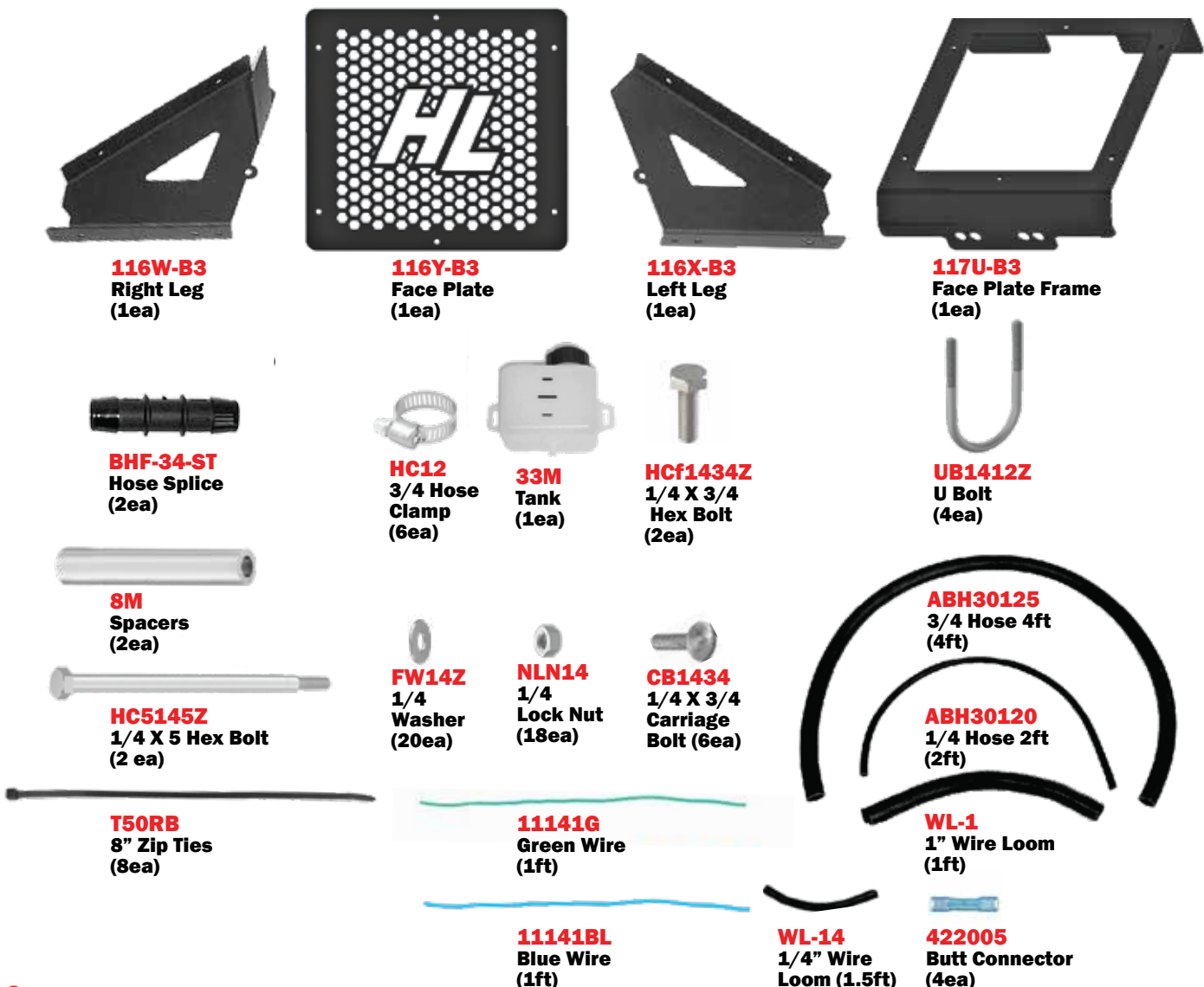

1

These items will need to be removed from the ATV, but leave the radiator attached to the fan and bracket. FOLLOW THE PROCEEDING STEPS FOR SPECIFIC INSTRUCTIONS ON REMOVAL.

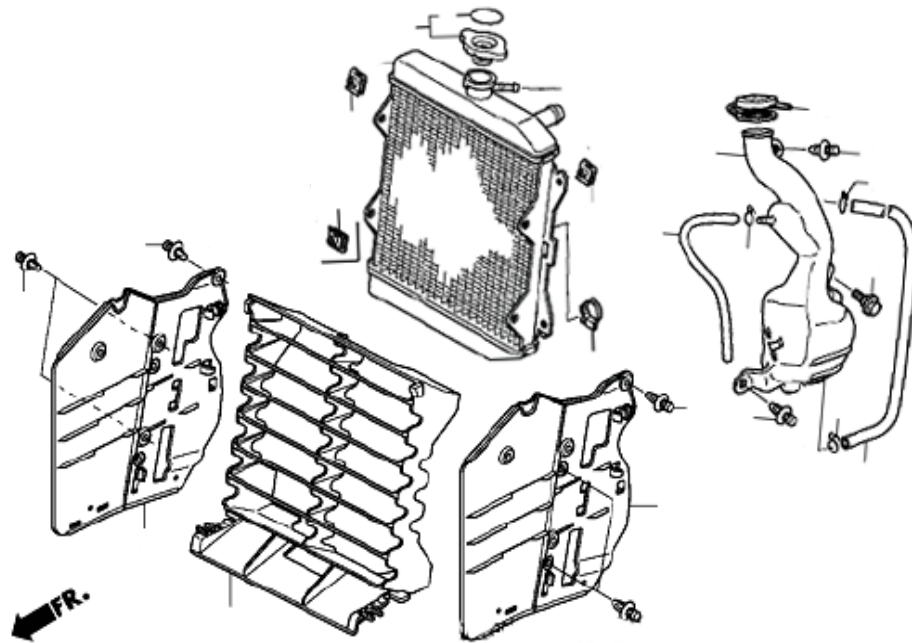

REMOVING STOCK COMPONENTS

2



Remove the cover from the top of the ATV to access the radiator, then unplug the radiator fan plug.



Dispose of used fluid according to your local regulations. Use care in disposal, antifreeze is toxic.

## REMOVING STOCK COMPONENTS

---

3



Remove the **plastic covers** to access the radiator.

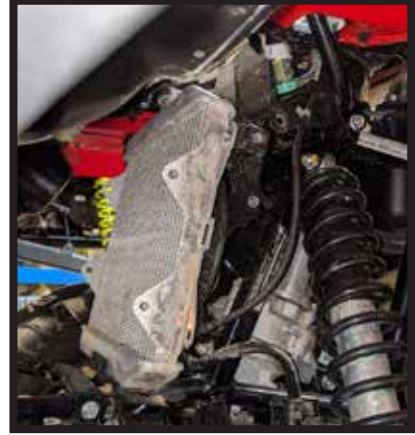
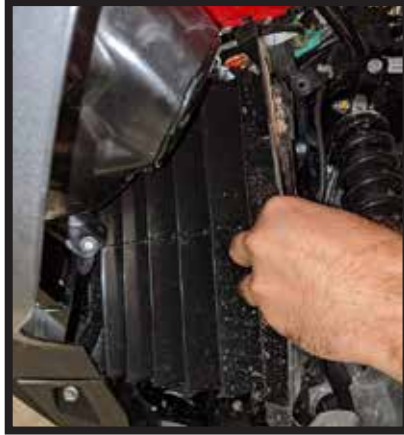

Begin to disconnect **hoses** and **drain fluid** from the radiator, being sure to leave **stock radiator hoses attached to the engine**.

## REMOVING STOCK COMPONENTS

---

4

Remove radiator assembly from the ATV and set aside.

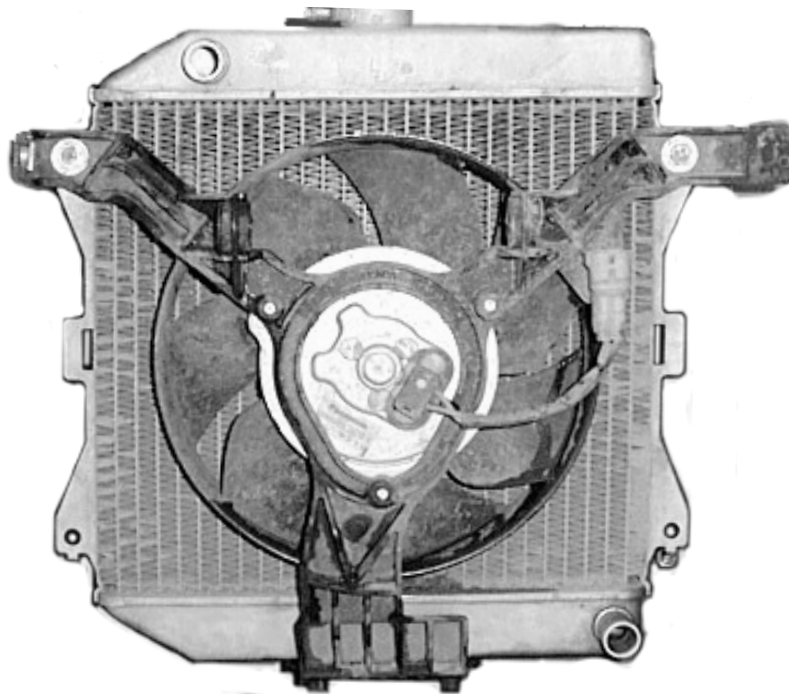



## ASSEMBLING RADIATOR MOUNT

---

5

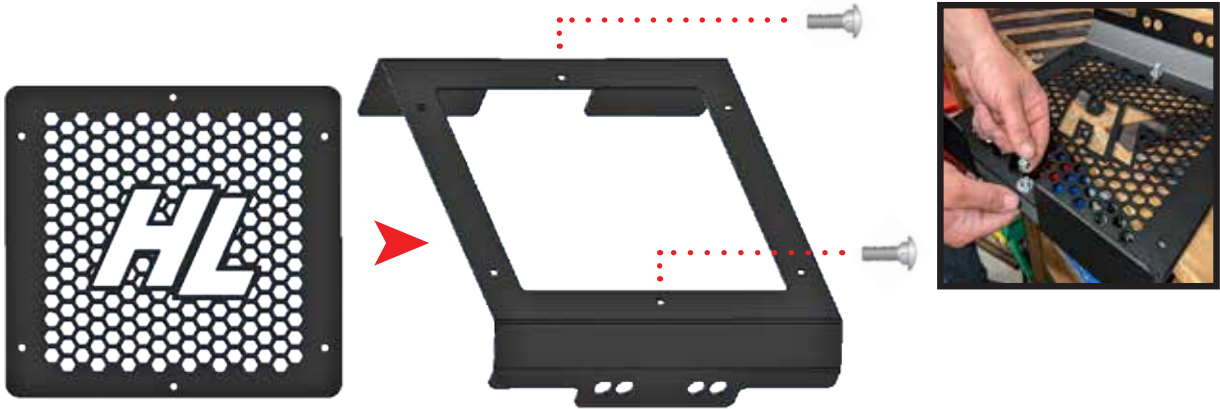

Start preassembling the the radiator mount by placing the **face plate BEHIND** the **plate frame** and install the **two 1/4 X 3/4 carriage bolts** to the center bolt holes then back it with the **two 1/4 washers** and **1/4 lock nuts** provided.

---

6



Attach the **left** and **right leg**, then begin installing the remainder of the **carriage bolts washers** and **lock nuts** and tighten them. **(6 total)**



7



Where the bottom of the stock radiator attaches to the frame there are two **rubber grommets** that you will need to **remove** and place in the two center holes at the base of the new **face plate**.

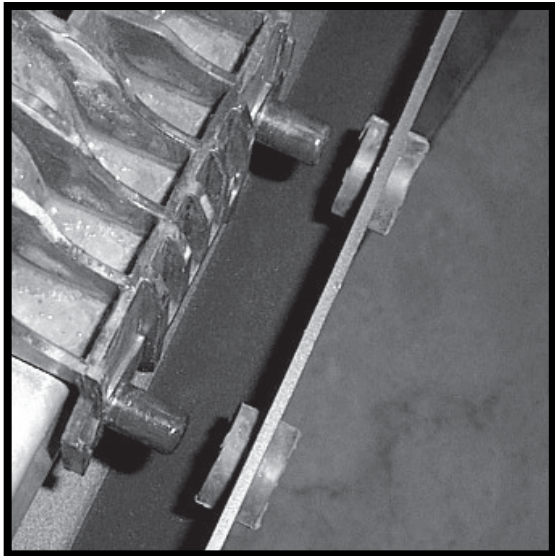

Once they are installed you will need to then insert the bottom of the radiator into the **grommets**.



FAN INSTALL

Trim Brackets

8

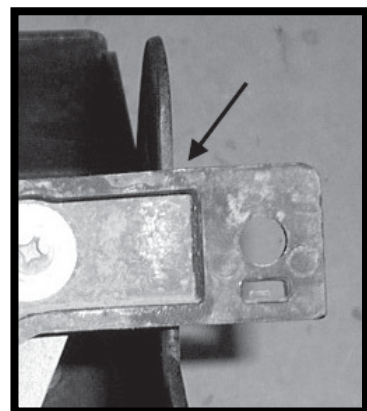
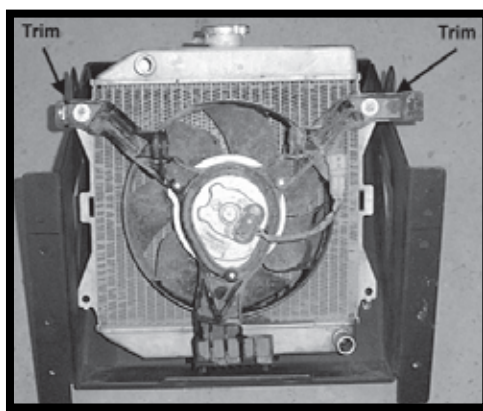
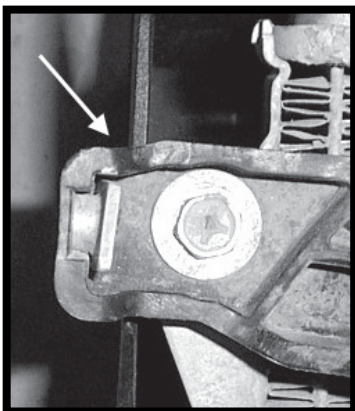

You will need to **trim** the stock **radiator fan brackets**, so that it will fit into the new shroud.



9

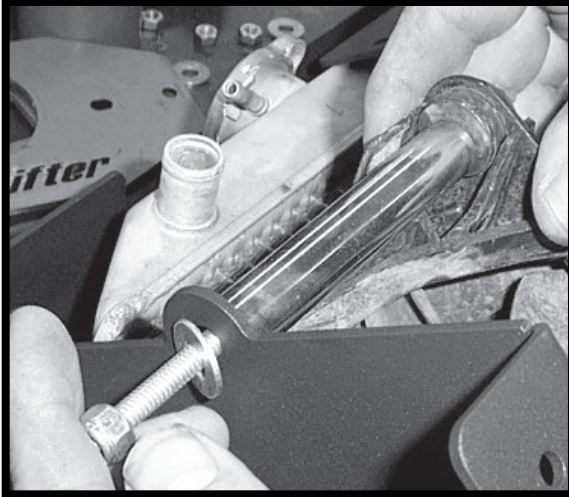

Next use the two **large spacers** and **1/4 X 5 bolts** to connect the fan to the brackets.

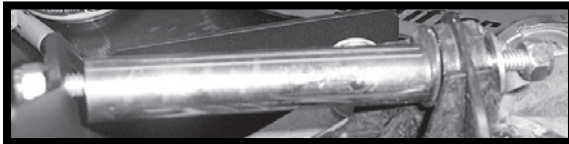

Place a **1/4" washer** on the bolt, push it through the connecting point of the frame. Next place a **spacer** on the bolt, then slide the bolt through the fan and secure it with **1/4" washer** and **1/4 lock nut**.

## FAN INSTALL

10

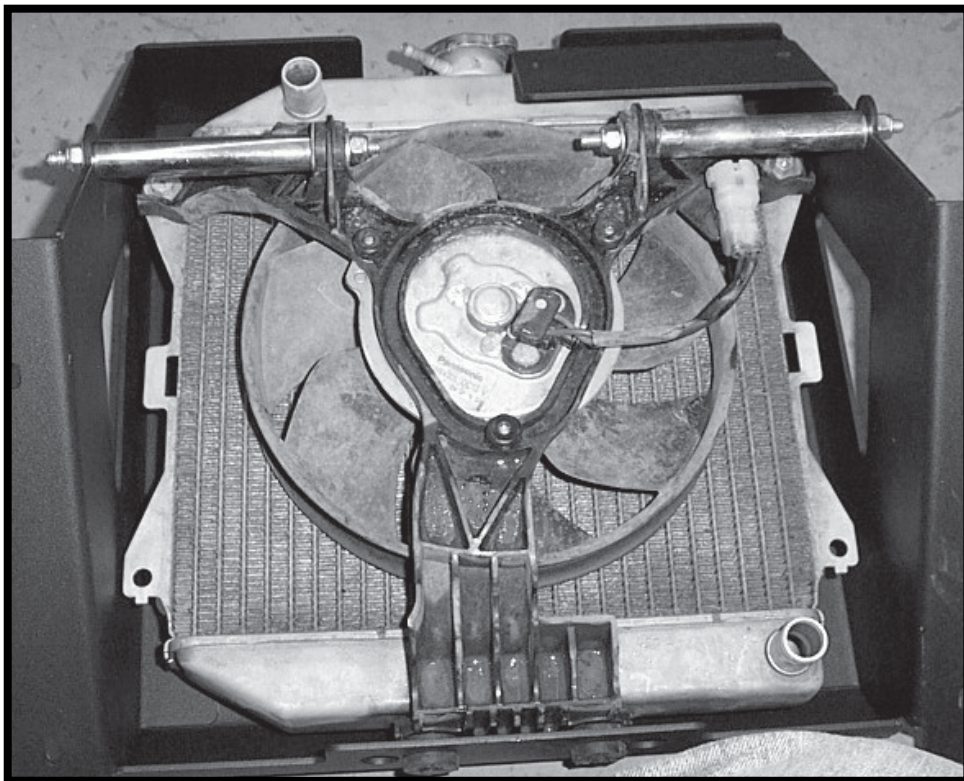

Once that is complete, your results should look like this.

11



Cut the **blue and green wire** half way between the **plug** and the **motor** on the back of the fan.

12

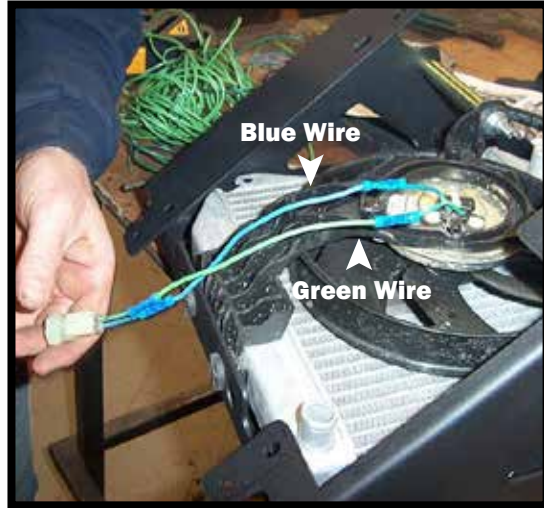

Using the **butt connectors** and **wire** provided, extend the **fan plug**. Attach the **green to green** and **blue to blue**.



**NOTE:** Once you have connected the wires, **wrap them in black tape** for added protection. Then **wrap them in 1/4 wire loom**.

Once the kit is assembled, place the kit on the front rack and loosely connect the **U-bolts** to the frame to prepare wire and hose routing.



## HOSE & WIRE ROUTING

13



Mark all holes to be drilled for the radiator hose then remove the radiator from the rack.

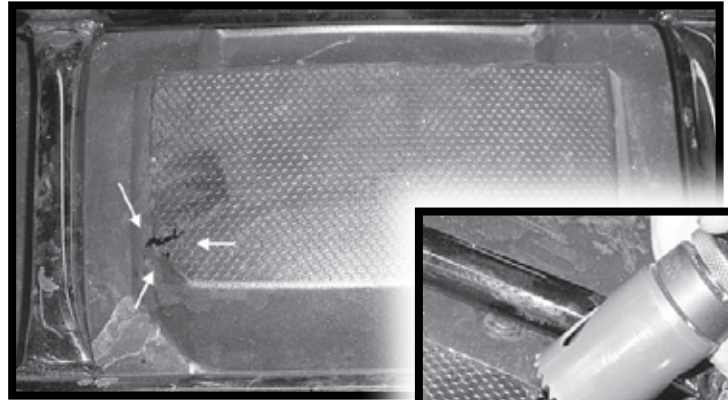

With a hole saw, drill the hole in the plastic, it needs to be **1 3/8"** in diameter.

14

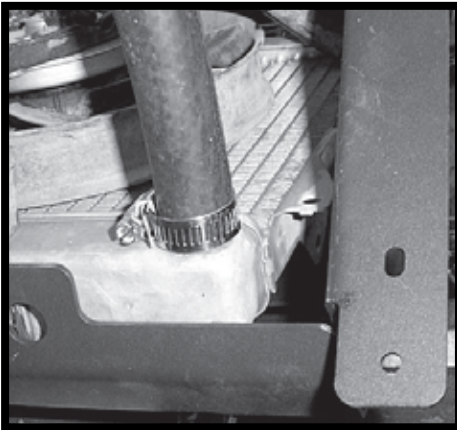

Connect **2ft of hose** to the bottom of the radiator. Secure the hose to the lower portion of the radiator with the **clamp** provided.

Cut **1"** wire loom in half and wrap the hose before inserting it through the plastic.



You need to insert the hose through the hole you drilled in the plastic as you are installing the radiator relocation kit to the rack.

15

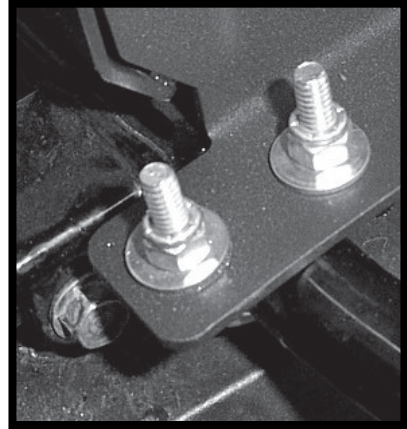
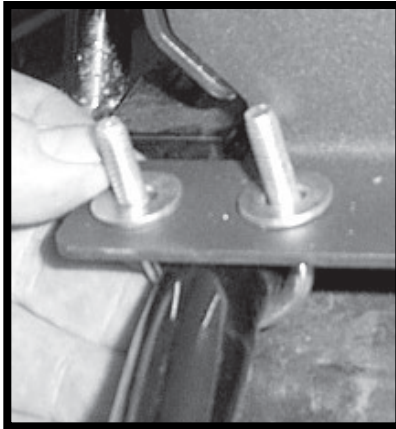
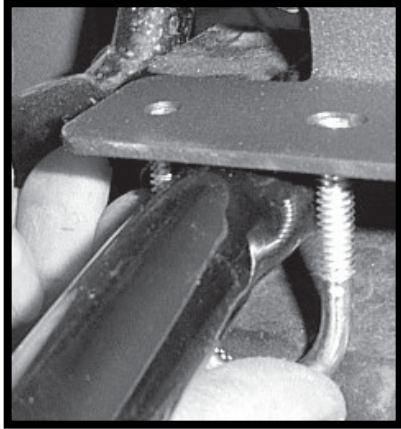

Connect the radiator to the rack using the 1/4 x 1" bolts, U-bolts, 1/4" washers and 1/4" lock nuts provided in the kit.

Access Panel Modification

16

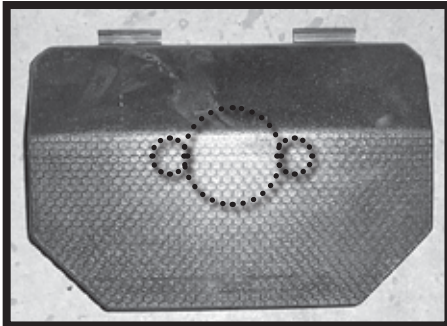

Locate the access panel and cut a 1 3/8" in hole in the center. If you DO NOT have a rotary tool we recommend you to use a 1/2" drill bit to drill out holes on the side for extra wiring space BEFORE drilling the 1 3/8" hole.

Mounting Tank

17

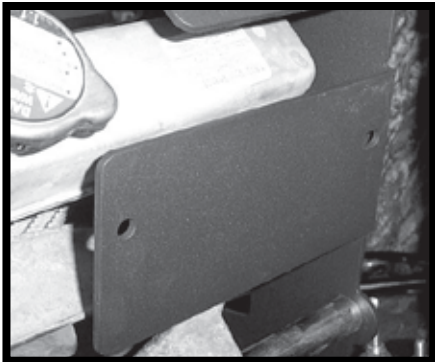

Located on the right leg of the relocation kit, connect the overflow tank to the mount. Use the 1/4" x 3/4" hex bolts, 1/4" washers, and 1/4" lock nuts provided.



18

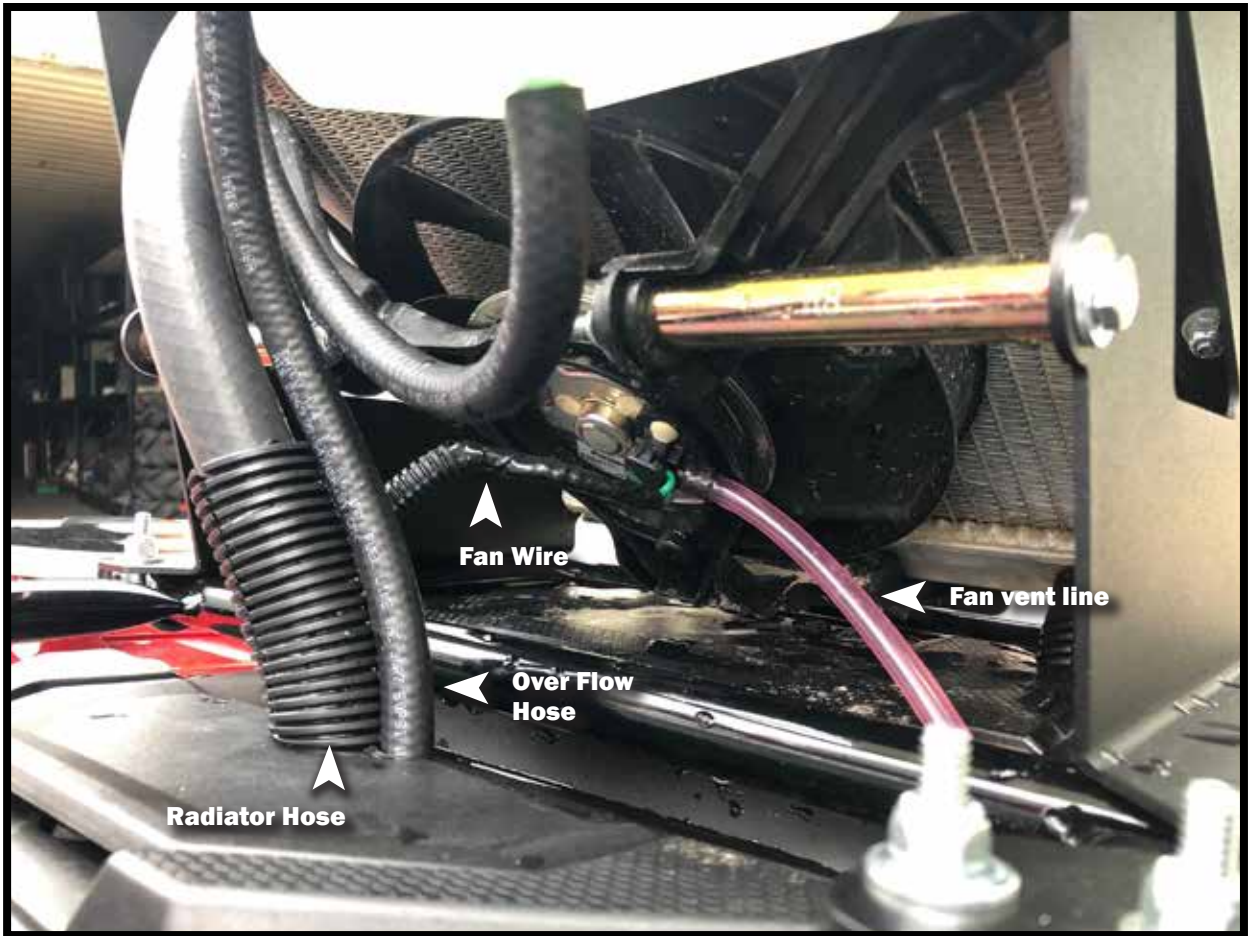

**IMPORTANT:** Place the **remaining loom** around the **hose** to keep it from rubbing on the rack and plastic fenders. If the hose is left unprotected the vibration of the hose against the rack and fenders will form a hole, causing fluid to leak out, potentially **RESULTING IN ENGINE DAMAGE**. **MAKE SURE ALL HOSES AND WIRES ARE COATED WITH LOOM.**

Fan and Hoses

19

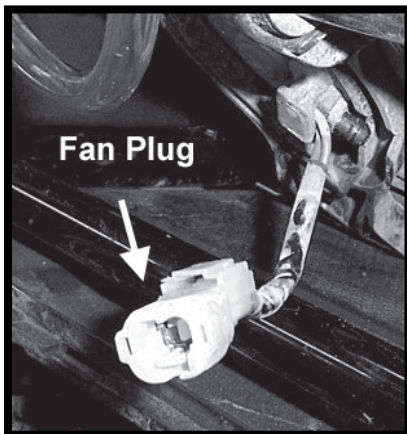

Push the fan wire through the access panel and reconnect it.

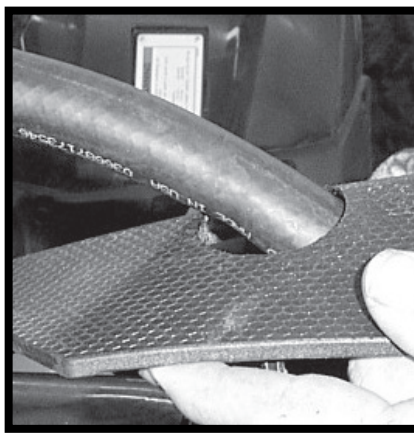

Now run 2 ft of hose through the access panel and cover it with loom.





20



Route the hose through the **access panel** down, and leave hoses hanging below. Then connect the other **end of hose to the top of the radiator** with a **clamp**.

Use the **zip ties** provided in the kit to secure all **lines, hoses, and wires**, so that they do not allow rubbing.

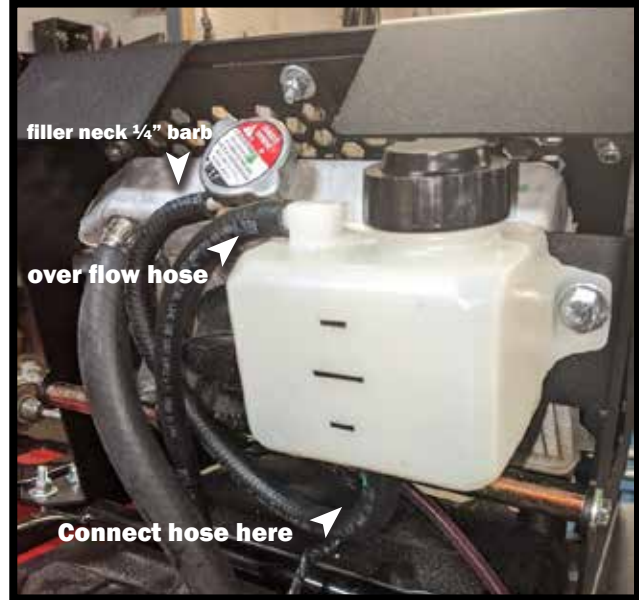

Connected to the radiator **filler neck** is a **1/4" barb**, cut **10"** of the **black 1/4"** hose provided, then connect the **1/4"** black hose to the **barb** on the **filler neck** and to the **1/4"** barb on the **bottom of the over flow tank**.

Using the remaining **1/4"** black hose provided, **route the over flow hose** from the tank down through **access panel**.

21

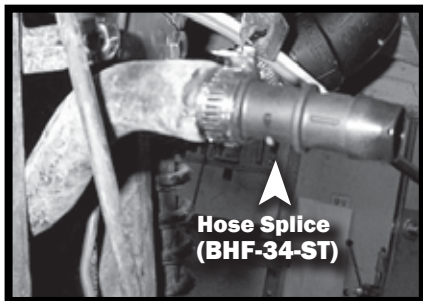

Once you have pushed the hoses through, connect the **inlet and outlet hoses** to the hoses you **left connect to the engine**. Secure the **hoses** to the **fitting** with the **clamps** provided in the kit.

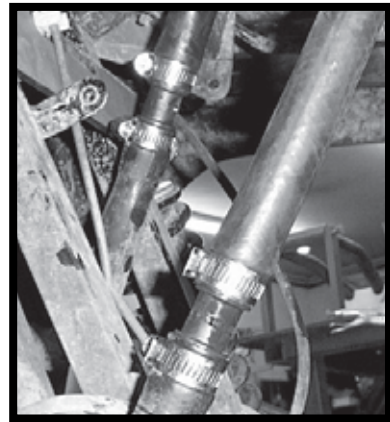
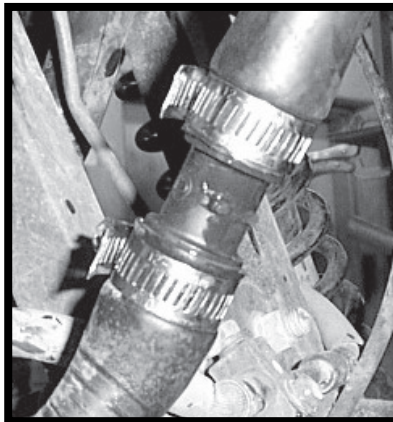

Fill radiator with factory approved fluids and check levels after a short distance. Air can get trapped in the system, so be sure that the levels are efficient. **The tank should be on the middle mark.**

**CONGRATULATIONS! Enjoy Your new High Lifter Radiator Relocation Kit!**



Thank You  
For Choosing  
**HIGHLIFTER**

# HIGHLIFTER



## HIGH LIFTER LIMITED LIFETIME WARRANTY

High Lifter offers a Limited Lifetime Warranty to the original purchaser that our product shall be free from defects in material and workmanship for the life of the product if utilized in accordance with the manufacturer's instructions for installation and operation of said products.

### LIMITED LIFETIME WARRANTY EXTENDS TO THE FOLLOWING PRODUCT LINES:

- **Lift Kits (Signature, Standard and Big Lifts)**
- **Control Arms**
- **Trailing Arms**
- **Radiator Relocation Kits**
- **Portal Gear Lifts**
- **Wheel Spacers**
- **Tow Hooks**
- **Control Arm Link Kits**

Damages to vehicle or any other object during the installation, use, or removal of High Lifter products are not covered under this warranty. Normal wear items included with any of the products covered under this Limited Lifetime Warranty are excluded from coverage. These items include, but are not limited to heim joints, tie rods, bearings, bushings, seals, gaskets, zinc plating, painted and powder coated finishes. Other exclusions of coverage under this warranty include, but are not limited to: damage or product failure due to improper installation, lack of maintenance, product modification, abuse, collision or use on vehicles for which product was not designed, repairs performed by anyone other than approved High Lifter personnel or made using non-High Lifter components. This warranty is valid for the original purchaser only and is non-transferable. High Lifter reserves the right to inspect any product before determining if the claim is valid and covered under this warranty. Claims determined to be caused by reasons other than a manufacturer defect will be rejected and an estimate for repair or cost of a replacement product if a repair is not possible, will be provided.

**This warranty is exclusive and is in lieu of any implied warranty of merchantability, fitness for a particular purpose or other warranty of quality, whether express or implied, except the warranty of title.**

### WARRANTY PROCESSING

If you suspect your product is defective, **DO NOT** disassemble the product to determine the cause without prior approval as it may void your warranty status. This is especially true with our Portal Gear Lift. To begin the claim process, please e-mail our warranty team at [warranty@highlifter.com](mailto:warranty@highlifter.com) and include the following in the e-mail:

- Your full name, address and contact phone number.
- The year, make and model of your vehicle
- The part number of the product
- Photos of the product installed, and vehicle product is installed on
- Proof of Purchase (Required for all warranty claims and you must be the original purchaser)

Once a claim is created, you will receive a return authorization number (RMA). Write this number on the outside of the box containing your defective product and include it along with your name and contact information inside the box. Product must be returned in the original box or a box of equal strength and packaging. Product sent without an RMA number visible on the outside of the box or sent COD will be refused. Ship your product to the following address:

#### High Lifter Products

**Attn: Returns 7455 Atkinson Drive. Shreveport, LA 71129**

Once your product is received, we often have your replacement or repaired product shipped back to you within 3-business days of receiving it. Please note that High Lifter is not responsible for shipping charges on product returned for warranty or repair, including duties and fees required by those residing outside the United States.

**THANK YOU FOR CHOOSING  
HIGHLIFTER**