

INSTALLATION INSTRUCTIONS

Power Steering Kit: for Arctic Cat[®] Wildcat Trail

Item	Description
A	Motor Mount
B	Stiffener
C	Support Plate
D	Upper Shaft
S	Lower Shaft

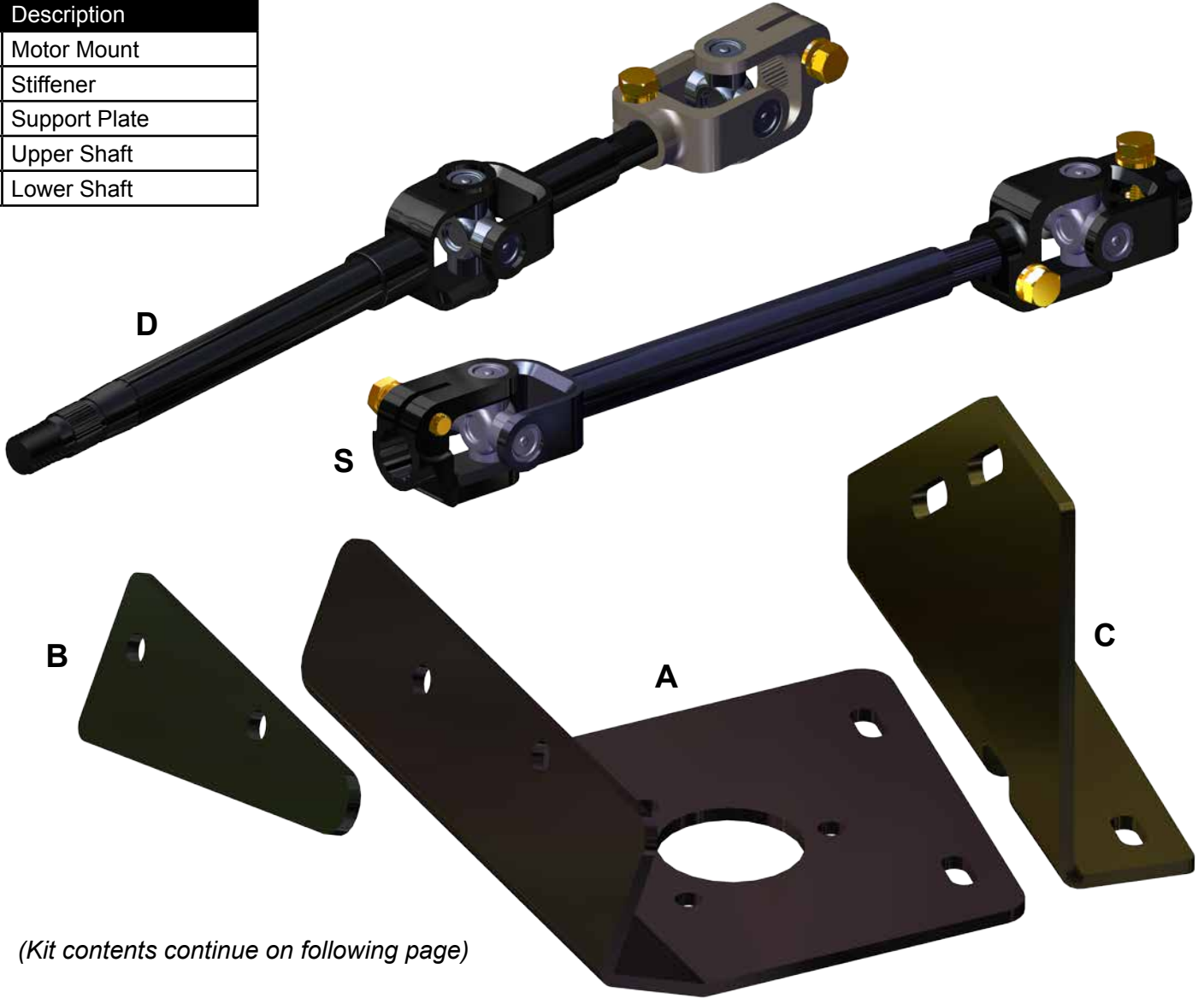

(Kit contents continue on following page)

Read instructions and view illustrations before beginning.

Need help with your installation?



sales@superatv.com



www.superatv.com



1-812-574-7777



8:00am - 9:00pm EST M-Th
8:00am - 7:00pm EST Friday
9:00am - 2:00pm EST Saturday

Thank You

For Choosing

SUPERATV[®].COM

Liability Statement

SuperATV's[®] products are designed to best fit user's ATV/UTV under stock conditions. Adding, modifying, or fabricating any factory or aftermarket parts will void any warranty provided by SuperATV[®] and is not recommended. SuperATV's[®] products could interfere with other aftermarket accessories. If user has aftermarket products on machine, contact SuperATV[®] to verify that they will work together.

Although SuperATV[®] has thousands of satisfied customers, user should be aware that installing lift kits, long travel, or suspension kits, tires, etc. will change the ride of machine and may increase maintenance and part wear. Operating any off-road machine while, or after, consuming alcohol and/or drugs increases risk of bodily harm or death. No warranty or representation is made as to this product's ability to protect user from severe injury or death. SuperATV[®] urges operators and occupants to wear a helmet and appropriate riding gear at all times.

By purchasing and installing SuperATV[®] products, user agrees that should damages occur, SuperATV[®] will not be held responsible for loss of time, use, labor fees, replacement parts, or freight charges. SuperATV[®], nor any 3rd party, will not be held responsible for any direct, indirect, incidental, special, or consequential damages that result from any product purchased from SuperATV[®]. The total liability of seller to user for all damages, losses, and causes of action, if any, shall not exceed the total purchase price paid for the product that gave rise to the claim.

SuperATV[®] will warranty only parts provided by SuperATV[®]. Any damage or problems with OEM housings, bearings, seals, or other manufacturers' products will not be covered by SuperATV[®]. SuperATV[®] parts and products are not warranted if item was not installed properly, misused, or modified.

(Kit contents continued)

Item	Description
N	Wiring Harness
P	Motor
Q	Control Module
R	Wiring Connectors Kit

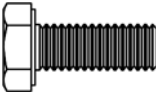

Qty. (2)  **M6-1.0 x 16mm Lg. HHCS**
-includes washers (not shown)

Qty. (3)  **M8-1.25 x 20mm Lg. FHCS**

Qty. (6)  **M8-1.25 Nylock Nut**

Qty. (6)  **M8-1.25 x 25mm Lg. FHCS**

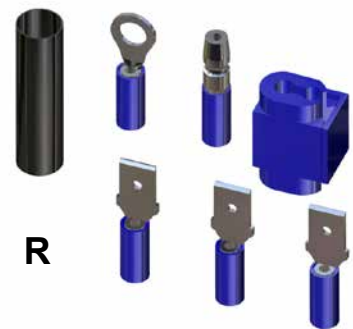

Connections

- Before installing, ensure that all waterproof connections are properly seated.
- If Gaskets are not seated, as shown, use a Flathead Screwdriver to seat.

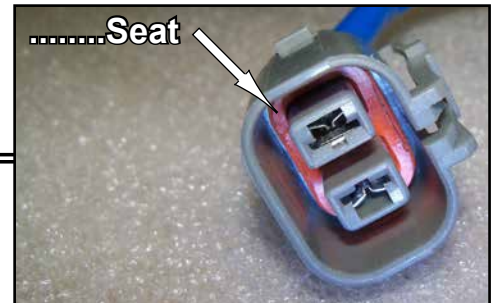
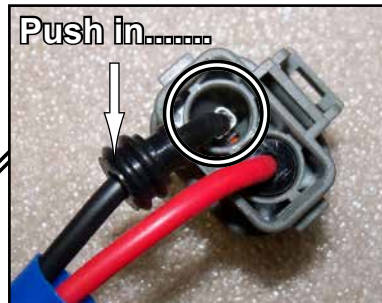
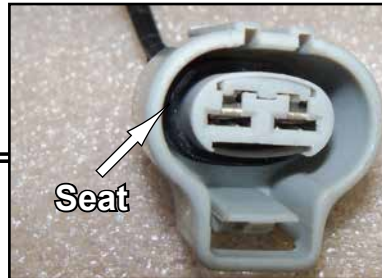

Removal: Keep all components removed from machine.

1. Remove Hood and Passenger Seat.
2. Remove Door Strikers, Steering Wheel, and hardware from Tilt Adjustor. See Figs. 1 - 1a.
3. Remove Push Pins and hardware securing Dash. See Figs. 2 - 2a.
 - Unplug Wire Harness' from Dash.
 - Remove Dash.
4. Unbolt Steering Shaft from Rack and Pinion, remove Steering Tube, and remove Steering Shaft.

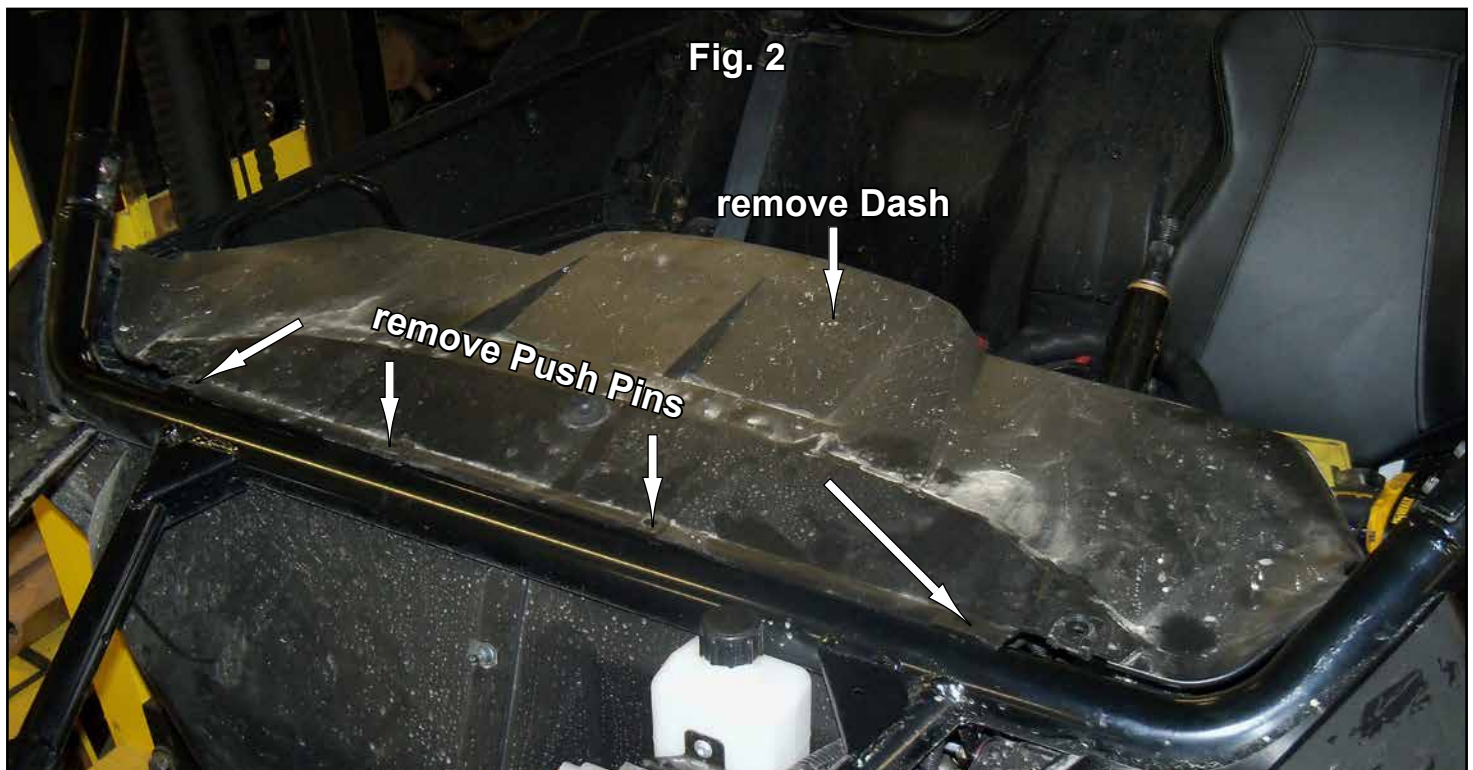
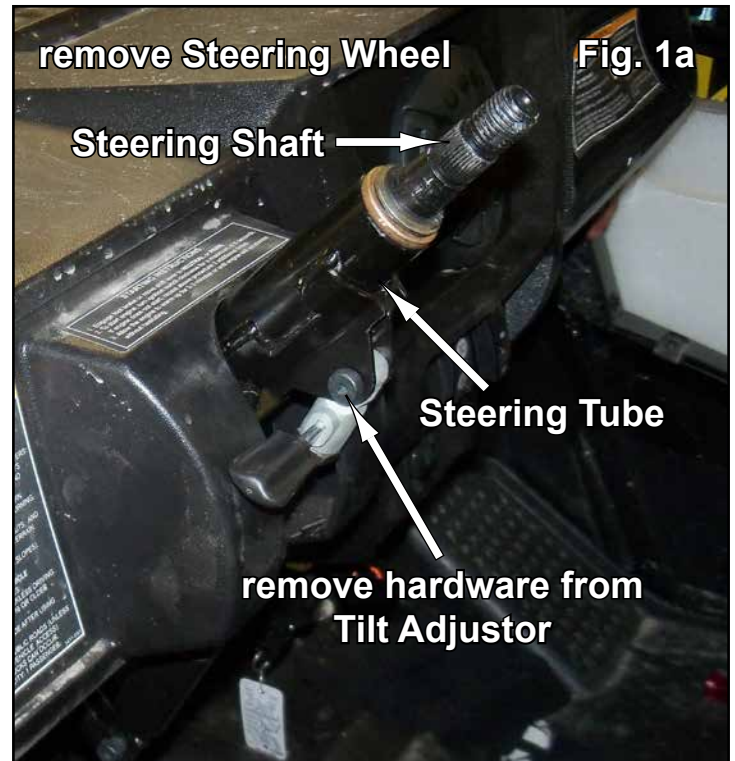
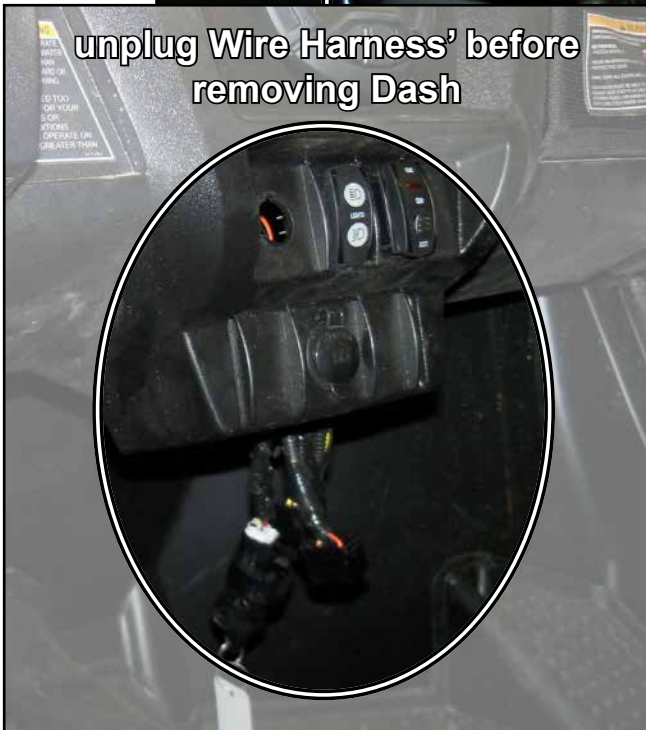

Fig. 2a



remove all Push Pins from under Dash

unplug Wire Harness' before removing Dash



Reference only; do not assemble at this time.

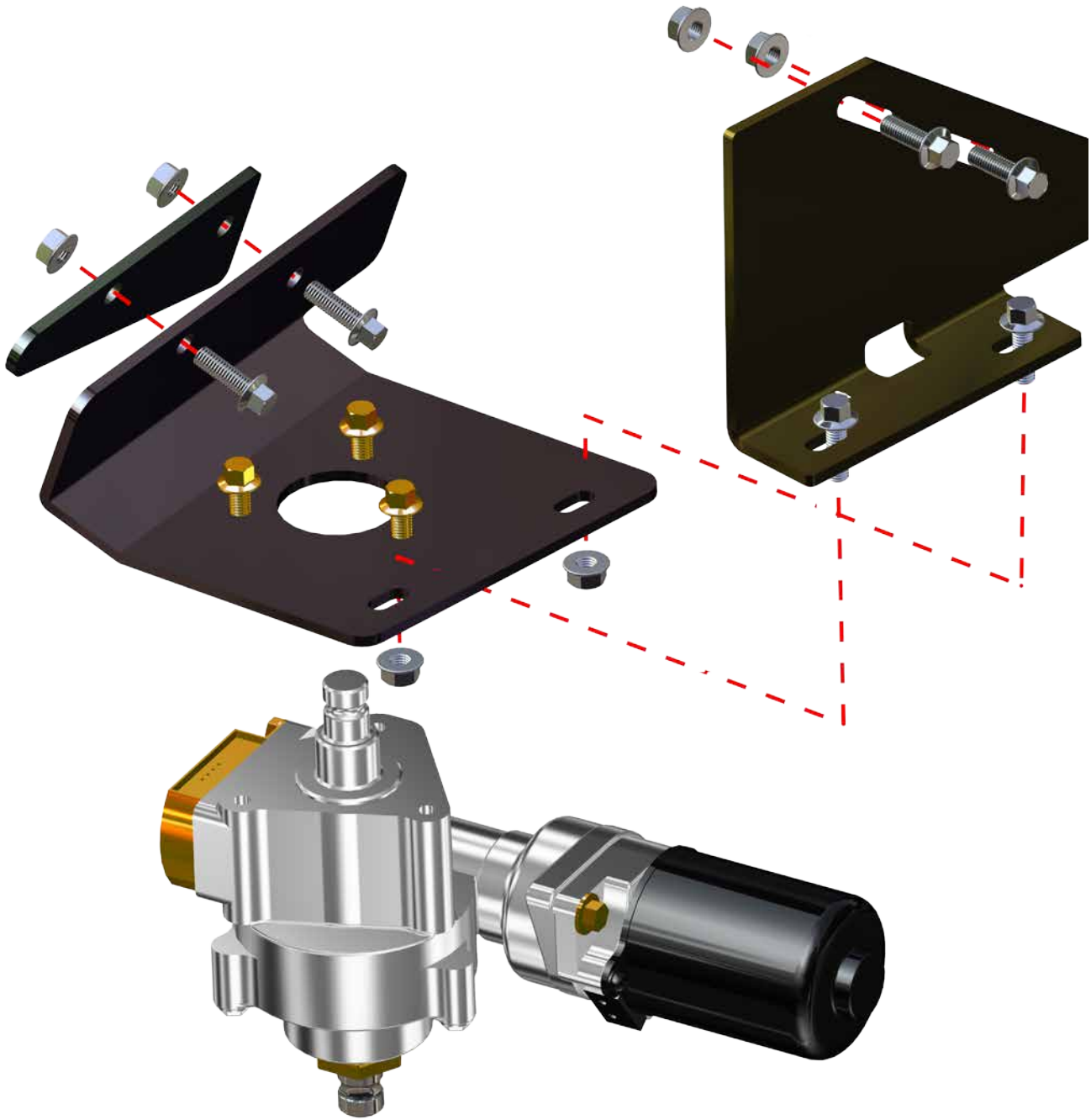

Installation: Do not tighten hardware completely unless noted.

1. Insert Lower Shaft (S) through Firewall and secure to Rack and Pinion with supplied hardware. See Figs. 1 - 1a. Tighten completely.
2. Install Motor (P) to Lower Shaft (S) and secure with supplied hardware. See Motor Shafts Detail and Figs. 2 - 2a.
3. Install Motor Mount (A) to Motor (P) with M8-1.25 x 20mm Lg. FHCS. See Fig. 3.
 - Install assembly and Stiffener (B) to Frame with M8-1.25 x 25mm Lg. FHCS and M8-1.25 Nylock Nuts. See Figs. 4 - 4a.
4. Install Support Plate (C) to Frame with M8-1.25 x 25mm Lg. FHCS and M8-1.25 Nylock Nuts. See Fig. 5.
 - Secure Support Plate (C) to Motor Mount (A) with M8-1.25 x 25mm Lg. FHCS and M8-1.25 Nylock Nuts. See Fig. 5.
5. Install Control Module (Q) to Frame with M6-1.0 x 16mm Lg. HHCS. See Figs. 6 - 6a.
 - Plug in Wiring Harness (N) but do not wire at this time.
6. Insert Upper Shaft (D) into Steering Tube and reinstall Steering Tube to Frame with stock hardware. Secure Upper Shaft (D) to Motor (P) with supplied hardware. Temporarily install stock Tilt Adjustor hardware to hold Steering Tube in place; remove when reinstalling Dash. See Figs. 7 - 7b.
7. Go to Wiring Details pages 12 - 13.
8. Tighten all hardware completely, reinstall Dash, Tilt Adjustor, and Steering Wheel.
9. Reverse steps taken during removal and reinstall necessary components.

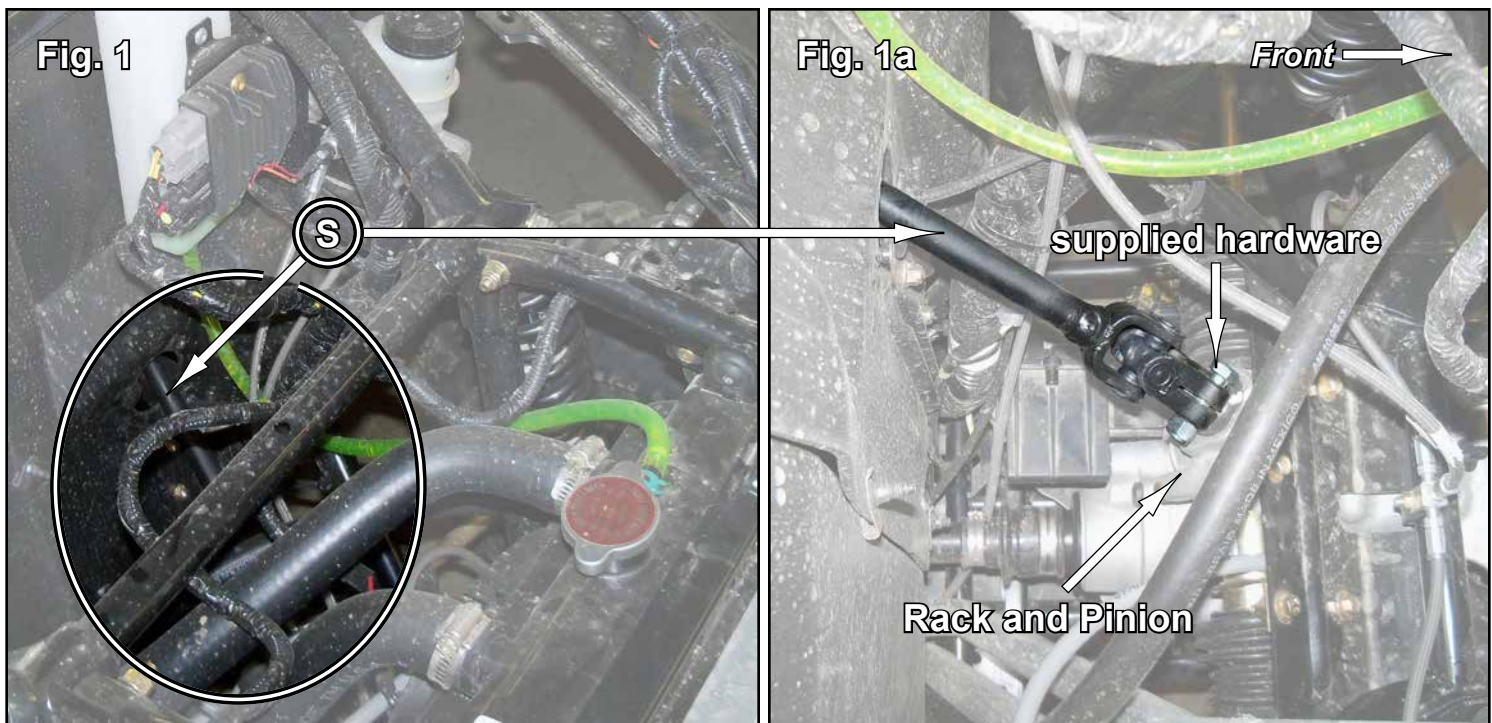

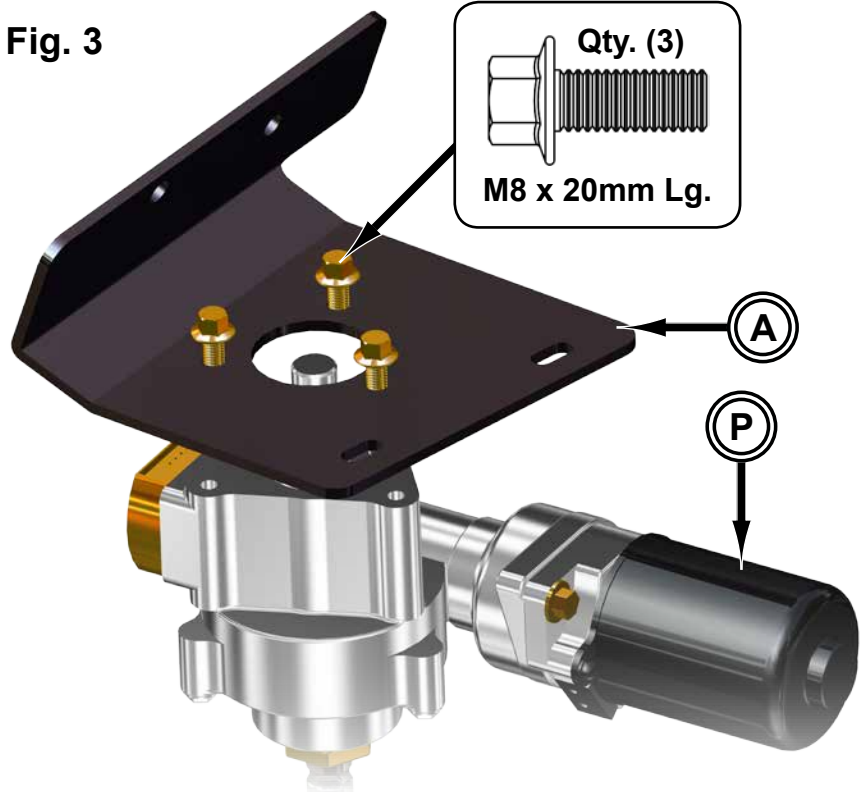
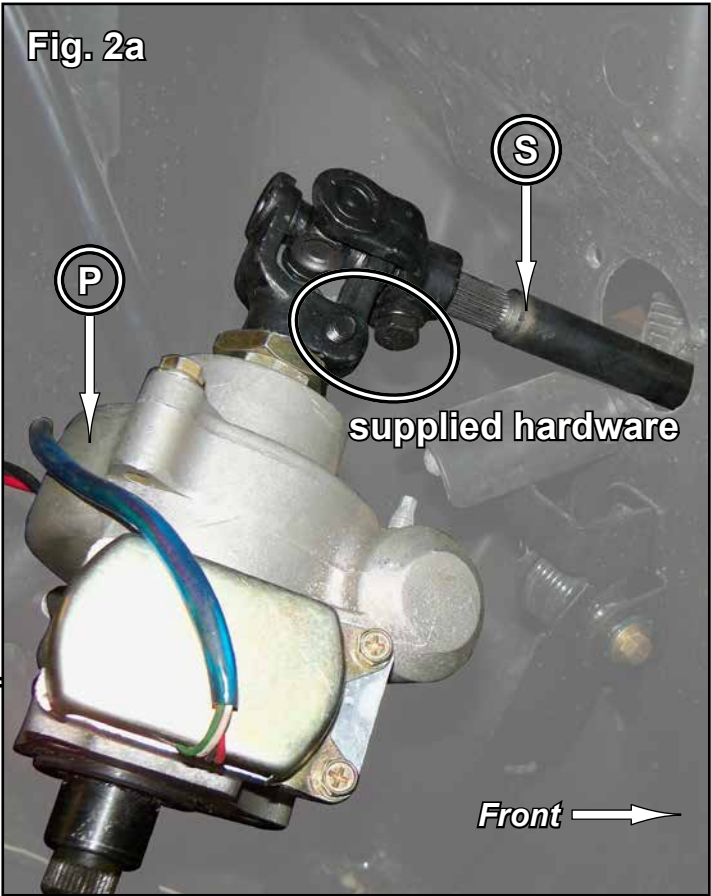
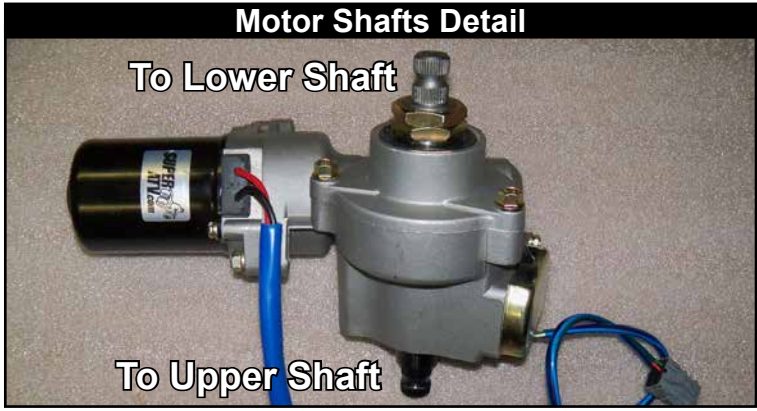

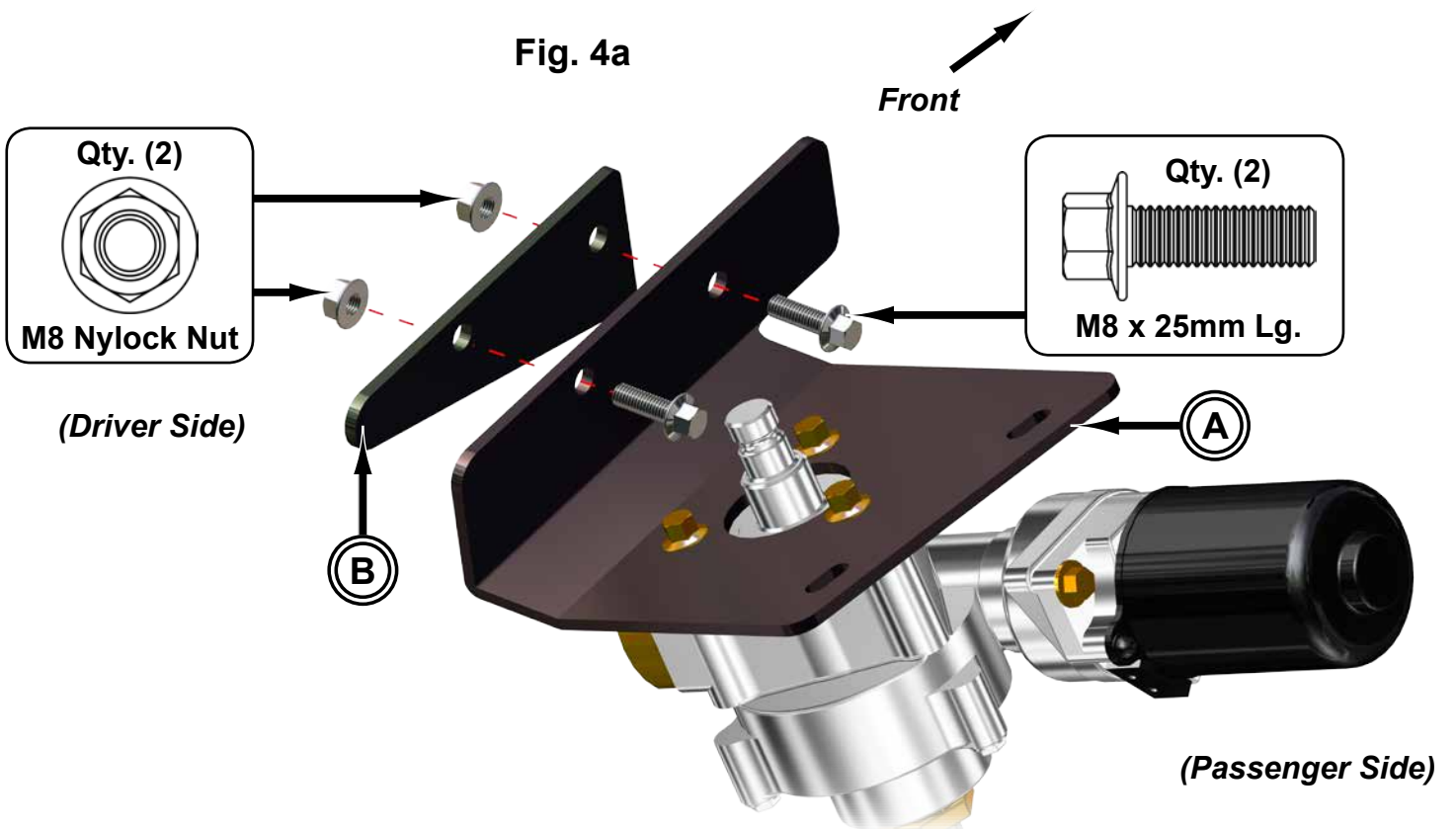
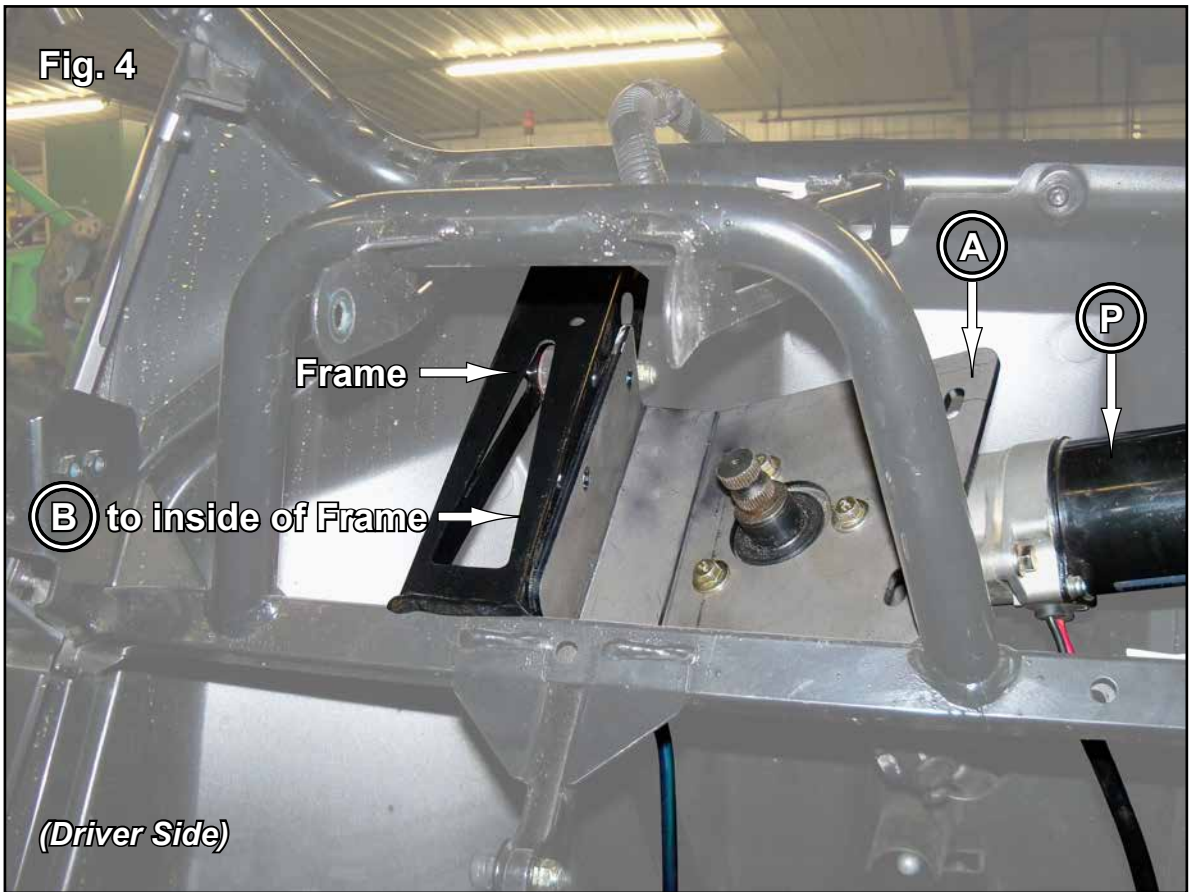
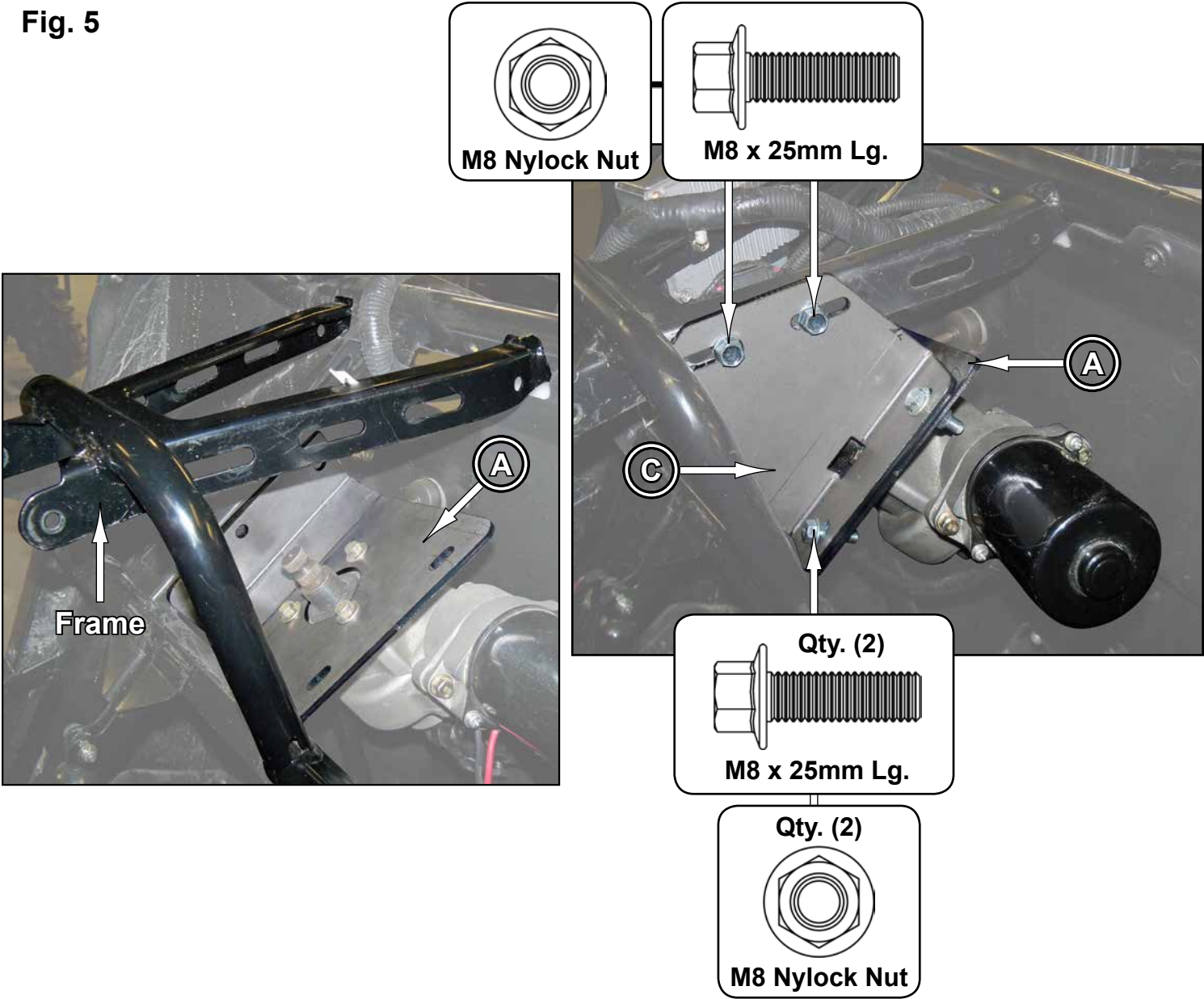
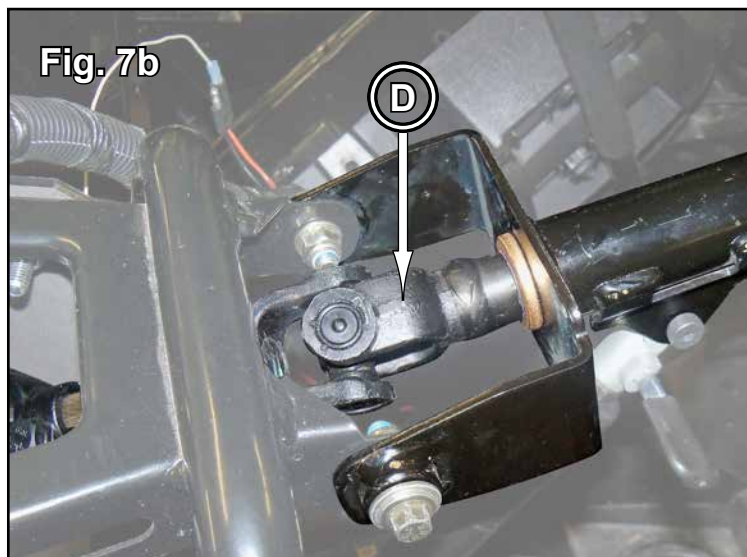
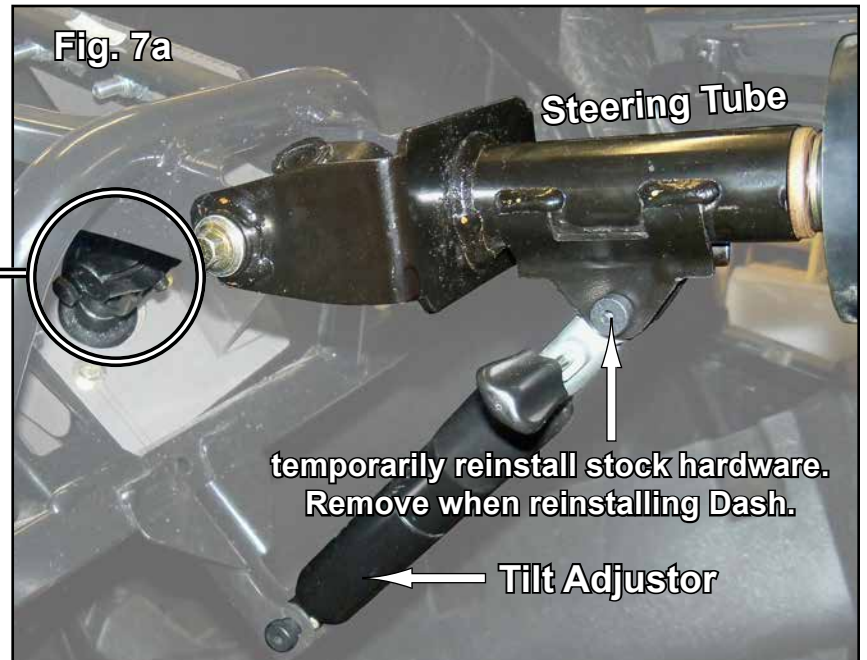
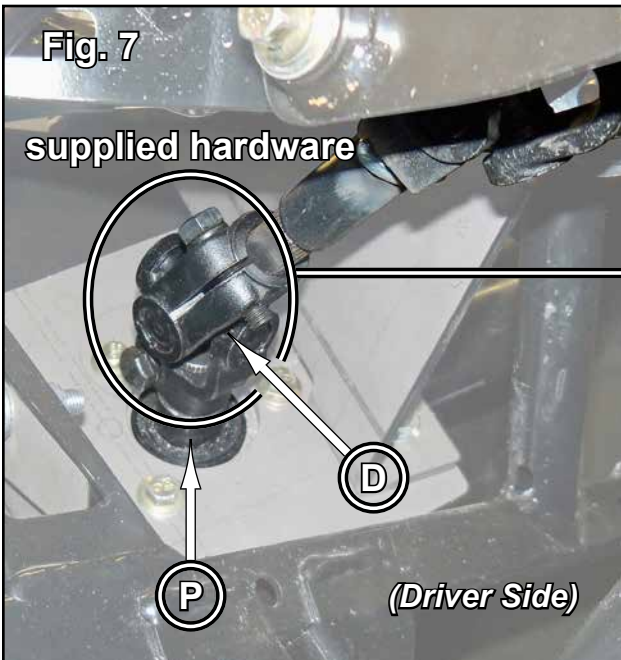
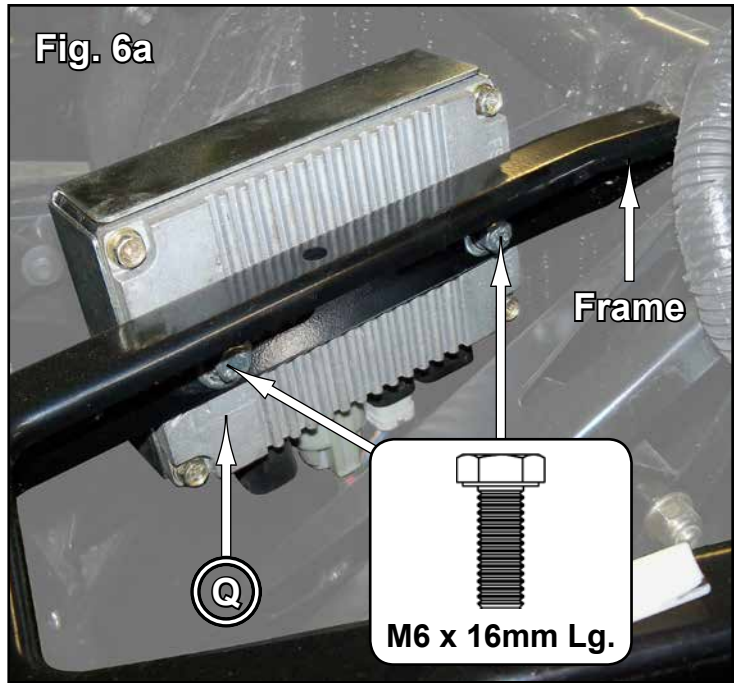
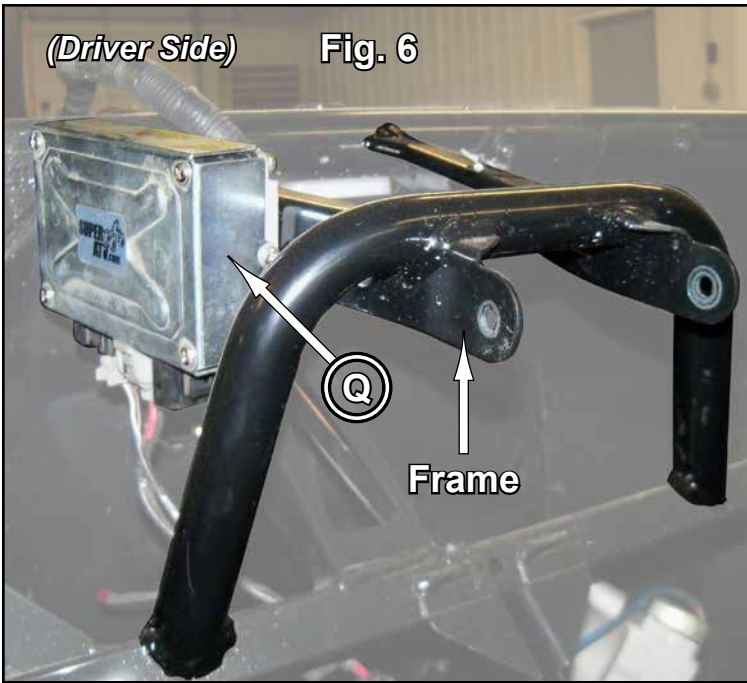

Fig. 5





Wiring Details

(White) To Switched 12V Source
(See 12V Source Connection Details)

(Black) To Battery, Negative (-)

(Red) To Battery, Positive (+)



When activated, Diagnostic Light will flash (1) time for about (1) second before turning off indicating proper function. Should different patterns occur, contact SuperATV.

Secure Diagnostic Light in a visible location.



Plug	Function
A	Torque Sensor
B	Switched 12V Source
C	Power
D	Motor

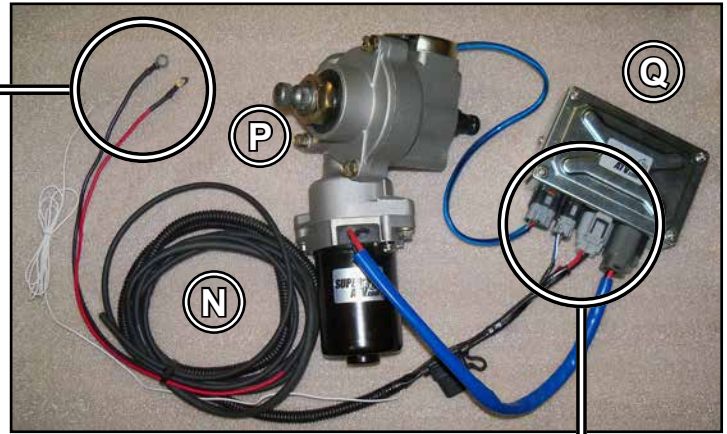

Switched 12V Source Connection

Connect White Wire from Wire Harness (N).

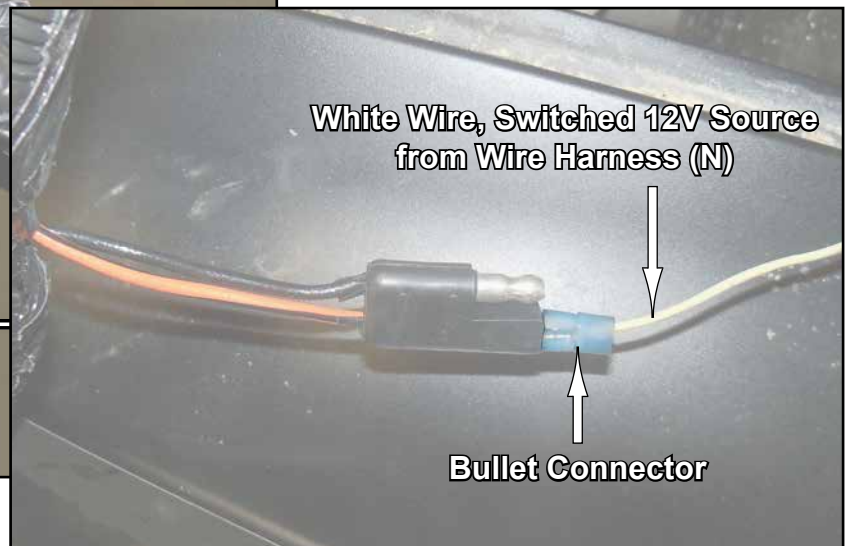

Power Connections

Route Black and Red Wires from Wire Harness (N) to Battery (located under Passenger Seat) and make connections. NOTE: Ensure that Wires are routed away from moving parts; secure wires accordingly.

