

FMP12

Series Milling Tools

Kr:90°

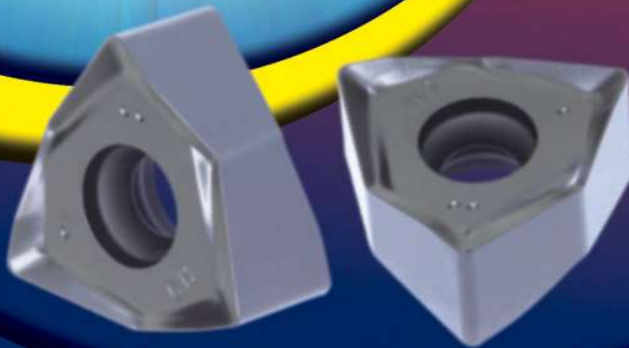

- Double negative angle of the cutter, combined with unique insert structure, to achieve double positive tool angle, which is beneficial to reducing cutting force;
- 6-flute cutting double-sided slot milling inserts, enabling high-quality 90° square shoulder milling, face milling and slot milling;
- Insert with wiper enables large feed and better surface finish.

Application case

Tool specification: FMP12-3.00"-A1.00"-WN08-05C
Insert specification/grade: WNHU080608PNR-GM/YBD152
Part Name: Turbine Housing
Workpiece material: QT450
Hardness: HB230-280
Cooling : Dry cutting
Machine: Vertical machining center
Cutting data: Vc=850SFPM, ap=0.04in, fz=0.004IPT, ae=1.18in
Milling style: Down milling Area of machining: End surface

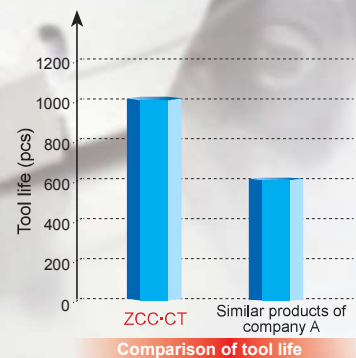
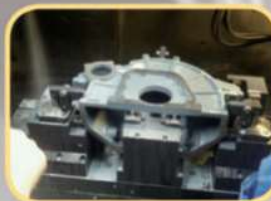

Face milling tools



FMP12 **P** **K** **N**

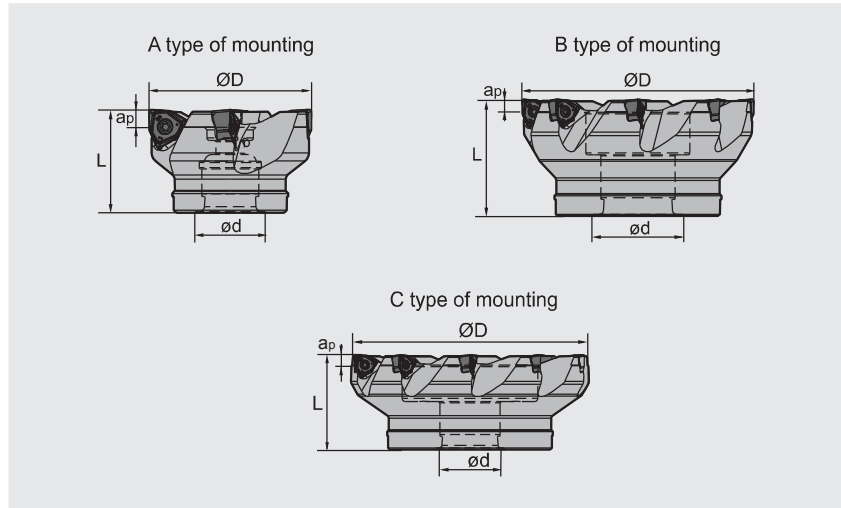



Specification of tools

Type		Dimensions(inch)					
		ØD	ød	L	apmax	Z (Number of teeth)	Interface form
FMP12	-2.00"-A0.75"-WN06-05C	2.00	0.75	1.75	0.224	5	A
	-2.50"-A0.75"-WN06-06C	2.50	0.75	1.75	0.224	6	A
	-2.50"-A1.00"-WN06-06C	2.50	1.00	2.00	0.224	6	A
	-3.00"-A1.00"-WN06-07C	3.00	1.00	2.00	0.224	7	A
	-4.00"-B1.25"-WN06-09	4.00	1.25	2.00	0.224	9	B
	-5.00"-B1.50"-WN06-11	5.00	1.50	2.50	0.224	11	B
	-6.00"-C1.50"-WN06-14	6.00	1.50	2.50	0.224	14	C
	-2.50"-A0.75"-WN08-05C	2.50	0.75	1.75	0.303	5	A
	-2.50"-A1.00"-WN08-05C	2.50	1.00	2.00	0.303	5	A
	-3.00"-A1.00"-WN08-06C	3.00	1.00	2.00	0.303	6	A
	-4.00"-B1.25"-WN08-08	4.00	1.25	2.00	0.303	8	B
	-5.00"-B1.50"-WN08-10	5.00	1.50	2.50	0.303	10	B
-6.00"-C1.50"-WN08-12	6.00	1.50	2.50	0.303	12	C	



Spare parts

Diameter ØD	Insert specification	Insert tightening screw	Wrench	Sketch of installation
				
Ø2.00"~Ø6.00"	WNHU06□□□□PNR-GM	I60M3×9	WT09IS	
Ø2.50"~Ø6.00"	WNHU08□□□□PNR-GM/LH	I60M4×10	WT15IS	

Face milling tools



FMP12 P K N

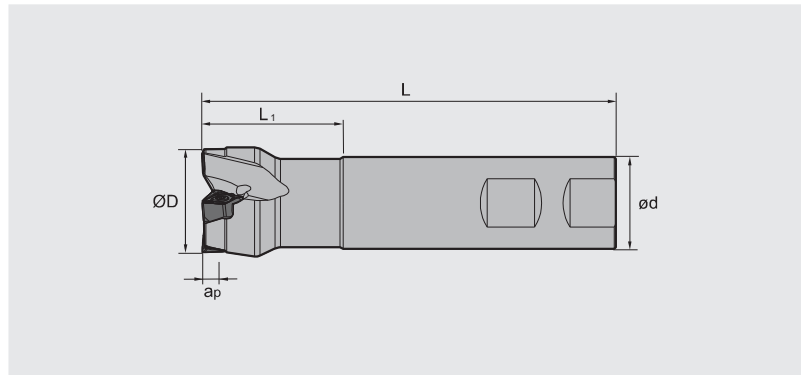



Specification of tools

Type		Dimensions(inch)					
		ØD	ød	L	L ₁	a _{pmax}	Z (Number of teeth)
FMP12	-1.00"-XP1.00"-WN06-02C	1.00	1.00	4.0	1.25	0.224	2
	-1.25"-XP1.00"-WN06-03C	1.25	1.00	4.5	1.50	0.224	3
	-1.50"-XP1.25"-WN06-04C	1.50	1.25	4.5	1.50	0.224	4
	-2.00"-XP1.50"-WN06-05C	2.00	1.50	4.5	1.50	0.224	5

D

Spare parts

Diameter ØD	Insert specification	Insert tightening screw 	Wrench 	Sketch of installation 
Ø1.00"~Ø2.00"	WNHU06□□□□PNR-GM	I60M3×9	WT09IS	

