

-MG Little squirrel series

-MG Series Chipbreaker

Suitable for parting, grooving, profiling, and turning. Good chip control and chip evacuation for good surface finish.

Insert design allows for use in many applications with need for fewer insert grades and configurations.

Inserts with the same cutting edge width can be used with different holders. Standardization with fewer inserts for internal, external, grooving and turning reduces tool inventory and tool management cost.

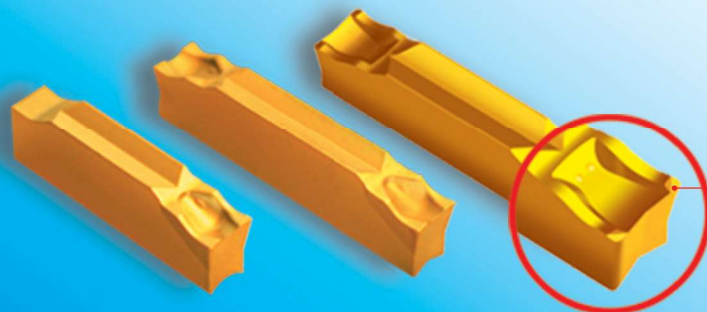
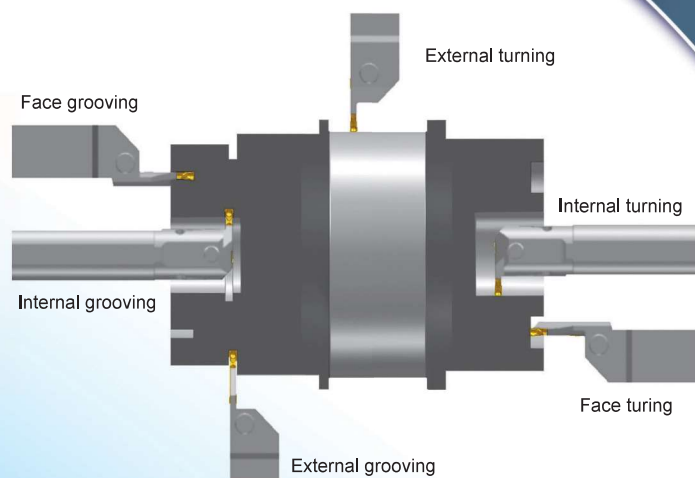

20% reduction in cutting force and reduced ovality.

Unique design of parting insert

- Insert uses specially designed flank to reduce cutting resistance by 20% with reduced machined surface ovality.
- A special design of the cutting edge requires less rigidity of machine. Older and lower horsepower machines can be used more productively.

