



# INSTALLATION INSTRUCTIONS FOR



**MODEL VSBX-730LED**  
[www.varsityscoreboards.com](http://www.varsityscoreboards.com)

# Table of Contents

DESCRIPTION.....	3
THE SCOREBOARD SYSTEM SHOULD INCLUDE THE FOLLOWING PARTS: .....	3
INSTRUCTIONS FOR REPORTING SHIPPING DAMAGE .....	3
INSTALLATION OVERVIEW .....	4
PRODUCT SPECIFICATIONS .....	4
Overall Dimensions:.....	4
Weight: .....	4
Mounting Recommendations: .....	4
Power Requirements: .....	4
Cable Recommendations (for cable-controlled systems only): .....	4
DETERMINING LOCATION AND ORIENTATION.....	5
INSTALLING MOUNTING POLES OR I-BEAMS.....	5
MOUNTING THE SCOREBOARD .....	6
RUNNING & CONNECTING THE CONTROL CABLE.....	9
At the scorekeeper’s location: .....	9
At the scoreboard: .....	11
RUNNING & CONNECTING THE ELECTRIC SERVICE .....	13
TESTING THE INSTALLED SYSTEM .....	<b>Error! Bookmark not defined.</b>
Testing the scoreboard system:.....	<b>Error! Bookmark not defined.</b>
IMPORTANT!.....	16
Warranty Activation/Installation & Completion Sign Off Sheet .....	16

# DESCRIPTION

## VS BX-730LED SCOREBOARD

**NOTE TO INSTALLERS: PLEASE RETURN THIS MANUAL TO THE INDIVIDUAL IN CHARGE OF THE SCOREBOARD UPON COMPLETION OF INSTALLATION.**

The scoreboard and all accompanying accessories have been carefully inspected and tested before leaving the factory. However, it is possible for damage to have occurred during shipping so we ask that you inspect all shipping containers upon arrival for damage and ensure that you have all of the parts listed below. If you find that damage has occurred during shipping, **DO NOT** refuse the shipment. Instead, accept the shipment from the carrier, follow the instructions for filing a freight damage claim found below, and notify the manufacturer immediately.

**THE SCOREBOARD SYSTEM SHOULD INCLUDE THE FOLLOWING PARTS:**

### **ITEMS IN LARGE PACKAGE(S)**

- (1) 4' x 8' Football Scoreboard, shipped in (1) section

### **ITEMS IN ACCESSORY BAG**

- (1) Handheld controller
- (1) CD ROM (including installation, operation, maintenance, warranty, and support information)

### **Cable-controlled systems (standard):**

- (1) 20-ft. control cable
- (1) Junction box covers with built-in 5-pin din socket
- (1) Customer-specified length of control cable

### **Wireless systems (optional):**

- (1) Wireless transmitter – built-in to the controller

## **INSTRUCTIONS FOR REPORTING SHIPPING DAMAGE**

Shipping damage must be noted at the time of delivery. Consignee must note "DAMAGED" on the Delivery Receipt Form. Please make notations of the type of damage to the freight and to the packaging. Ask the delivery driver to call the local terminal and report immediately. The shipper is **not responsible** for the shipments that are not signed for as damaged upon arrival. Please contact the manufacturer immediately to report the damage. The shipper is responsible for filing the claim, unless shipped 3RD Party.

If damage is discovered after delivery, call the delivery company to report the concealed damage and please call the manufacturer immediately to report. Concealed damage must be reported within 5 days after delivery date. If the damages are found after this time, the manufacturer will not be responsible.

# INSTALLATION OVERVIEW

This manual will walk you through the installation of the scoreboard. While care has been taken to consider the many scenarios for installation, some general information applies to all. Use this guide as closely as possible to ensure proper installation, as follows:

1. Review the product specifications below to determine your specific installation hardware.
2. Determine the scoreboard's location and orientation.
3. Install the mounting poles/I Beams (supplied by the customer).
4. Mount the scoreboard to the poles/I Beams (**mounting hardware supplied by customer**).
5. Install the control cable for cable-controlled systems (**not necessary for Wireless Remote Control systems**).
6. Install the electrical service for the scoreboard and the controller.
7. Install any options, such as sponsor panels or protective nets, according to the installation instructions included with each option package.
8. Test the installed system.
9. Fax/return warranty activation sheet to Scoreboard Service Company at (270) 753-3773.

## PRODUCT SPECIFICATIONS

### Overall Dimensions:

4' x 8 x 8" - shipped in one (1) section

### Weight:

Hanging weight = approximately 180 lbs  
Shipping weight = approximately 240 lbs.

### Mounting Recommendations:

(2) 8" steel I-beams (W8 x 31) **OR** (2) 8" OD galvanized steel poles (schedule 40); total length determined by local codes, customer preferred mounting height, and scoreboard options.

### Power Requirements:

Scoreboard:

(1) 120-volt, 20-amp, 60 Hz grounded AC circuit connected to a power disconnect switch or circuit breaker (refer to the wiring diagram on page 9 for instructions on determining the scoreboard's power requirements – specific power requirement information is also marked on the scoreboard's serial number label, located on the scoreboard)

Hand held controller:

Will be powered through the communication cables from the scoreboard terminated at the connection at the wall cover plate.

### Cable Recommendations (for cable-controlled systems only):

Four conductor cable – 28 gauge, twisted pair (two pairs), shielded data cable

# DETERMINING LOCATION AND ORIENTATION

The scoreboard should be positioned so that the greatest number of spectators can easily view it. Also, consider the best orientation of the scoreboard should the system be used to score a daytime or afternoon game. The scoreboard should be positioned so that sunlight does not glare off of its face. In the U.S., placement on the South or West side of the field is recommended. Consult with the local building or zoning department before final determination and installing the scoreboard.

## INSTALLING MOUNTING POLES OR I-BEAMS

**NOTE:** The following information for installing the mounting poles/beams are suggestions only. Local codes, field placement, scoreboard options, customer preference, and other special considerations will determine the specifics of your installation, including footer specifications, above ground height, and total length of the poles/I-beams.

1. Install the two (2) mounting poles/I-beams (supplied by the customer) on the field with 4' center spacing and with 14'-6" of pole/I-beam above ground (refer to the figures below).

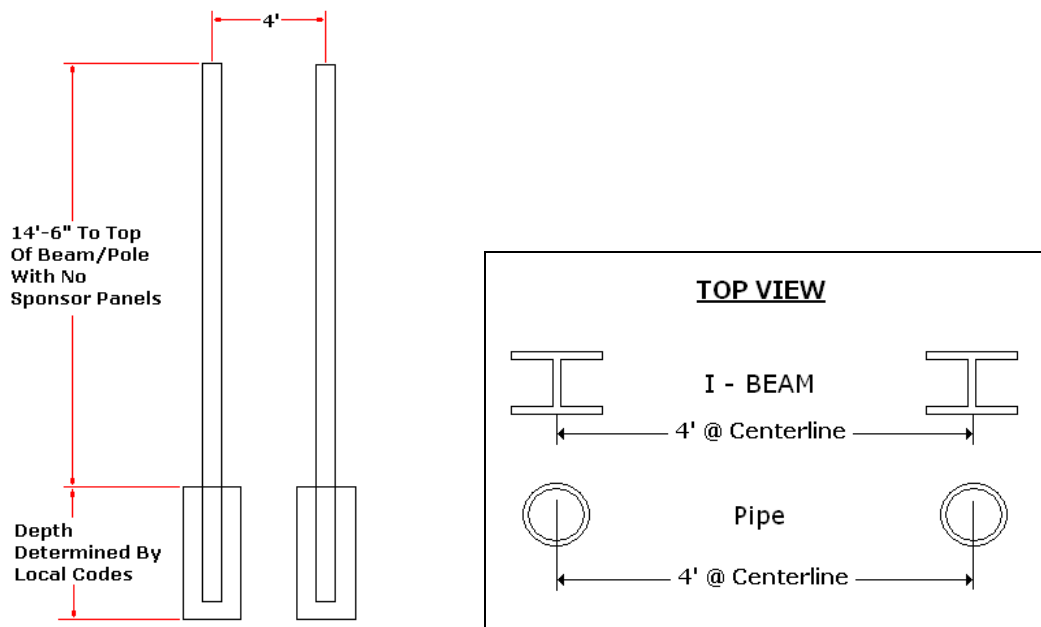

2. The poles/I-beams must be set into concrete footers. Make sure the poles are level and plumb and spaced on 4' centers. The mounting faces of I-beams must be straight with each other. If the face of an I-beam is turned, shims will be needed to mount the scoreboard. The required dimensions for the footers vary depending on local building codes, soil & weather conditions, and scoreboard size. Consult with local building officials for the required pole sizes and footer construction regarding this installation. A local architect, structural engineer, or sign installer may also be a source of assistance.

**IMPORTANT: DO NOT MOUNT THE SCOREBOARD TO A WALL. A MINIMUM OF 18” – 24” CLEARANCE MUST BE MAINTAINED FOR ACCESS TO THE BACK OF THE SCOREBOARD CABINET. CONTROL MODULE, POWER, AND SIGNAL CABLE CONNECTIONS ARE ACCESSED ON THE BACK OF THE SCOREBOARD.**

## **MOUNTING THE SCOREBOARD**

NOTE: IF THE POLES/I-BEAMS ARE NOT IN ALIGNMENT --- SHIMS MAY BE NEEDED TO MOUNT THE SCOREBOARD PROPERLY. MOUNTING THE SCOREBOARD WITH THE POLES/I-BEAMS OUT OF ALIGNMENT MAY DAMAGE THE SCOREBOARD AND VOID THE WARRANTY.

1. Using the lift holes provided, connect a lift device to the scoreboard, as in the image below.

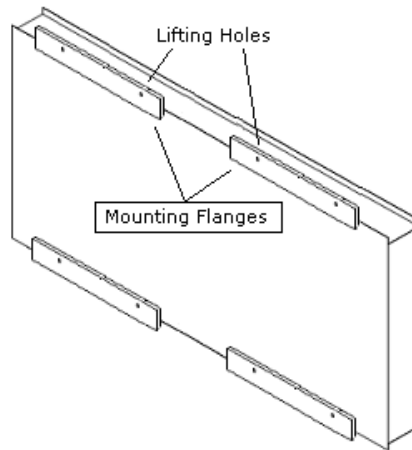

2. Lift the scoreboard into place to the desired height, ensuring that the scoreboard is level.
3. Secure the scoreboard to the poles/beams using the mounting flanges attached to the scoreboard. The unit must be attached to each pole/beam on top **and** bottom.
4. If using steel I-beams, either weld the mounting flanges to the supports, or drill the mounting flanges and supports to use bolts, washers, and nuts to secure the scoreboard to the I-beams.
5. If galvanized steel poles are being used, weld or bolt steel angles to the mounting flanges, which can then be welded to or bolted *through* the pole. Refer to the figure on the next page for detailed illustrations of these suggested mounting methods.

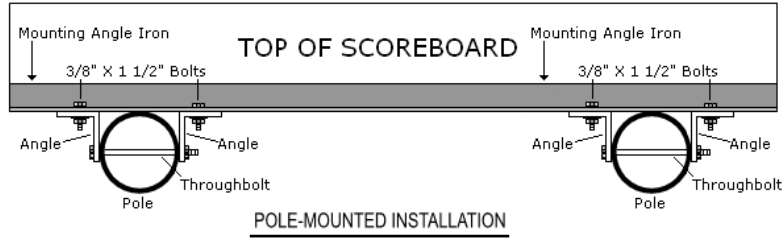
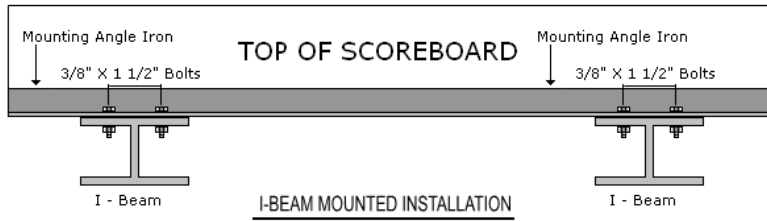

**NOTE: MOUNTING HARDWARE SUPPLIED BY CUSTOMER**

Scoreboard Dimensions:  
4' tall x 8' wide x 8.0" depth

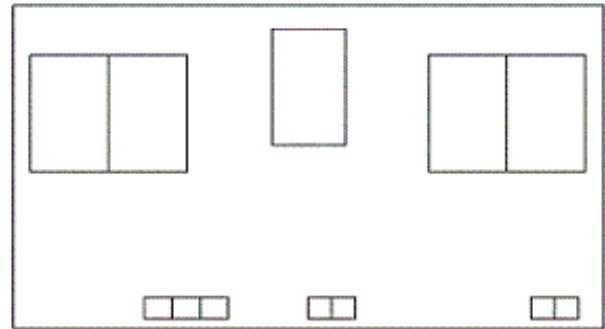

Front View: Mounted

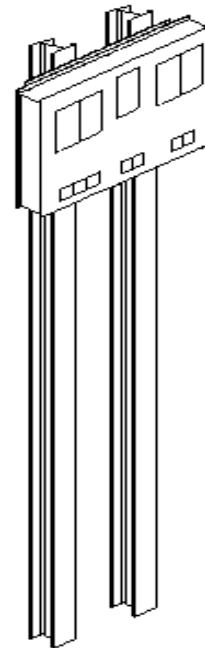

Rear View: Mounted

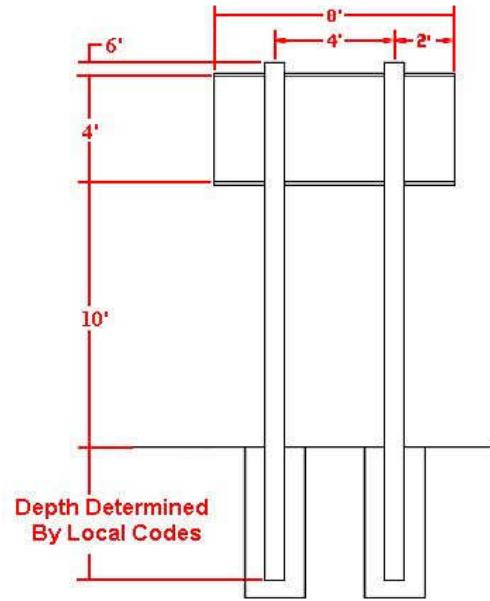

# RUNNING & CONNECTING THE CONTROL CABLE

**(For scoreboards with Wireless Remote Control, skip this step.)**

The control cable must be run in a separate conduit than is used for the electrical service. The control cable should run from the scoreboard to a location that is within 10 feet of the scorekeeper's location and into a 2"X4" wall box.

At the scorekeeper's location:

1. With the communication cable installed between the scoreboard and the 2"X4" wall box, locate the wall plate provided with your installation hardware.

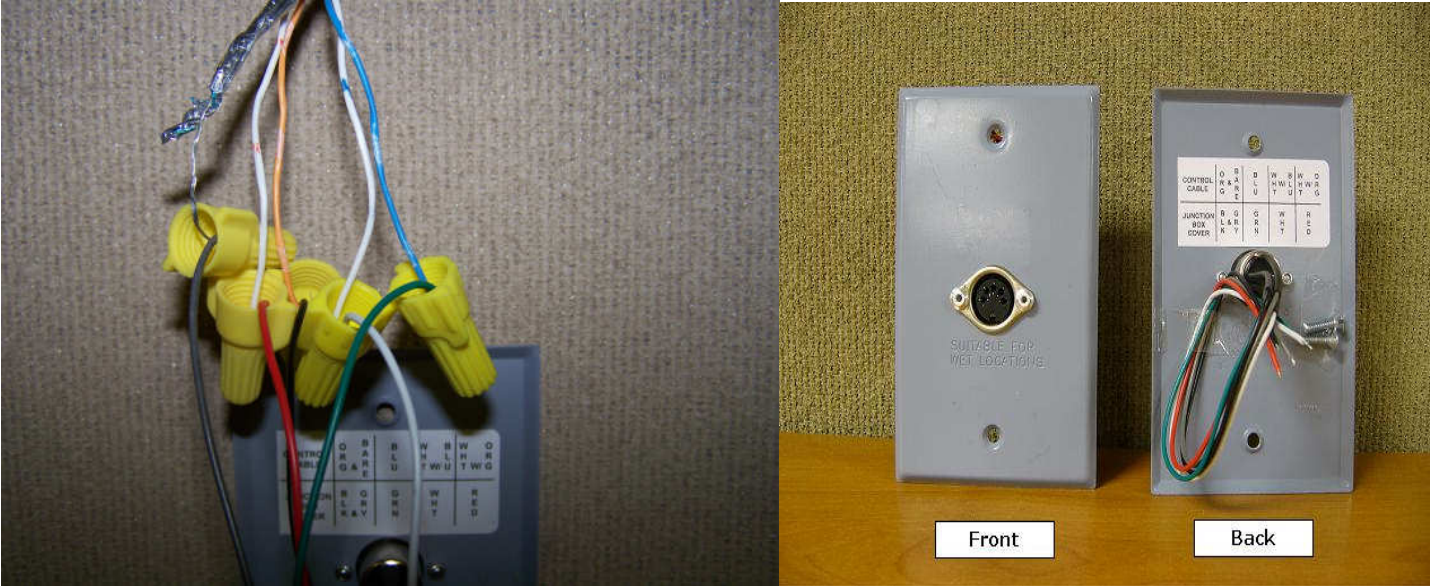

## JUNCTION BOX COVER AT SCOREKEEPER'S LOCATION

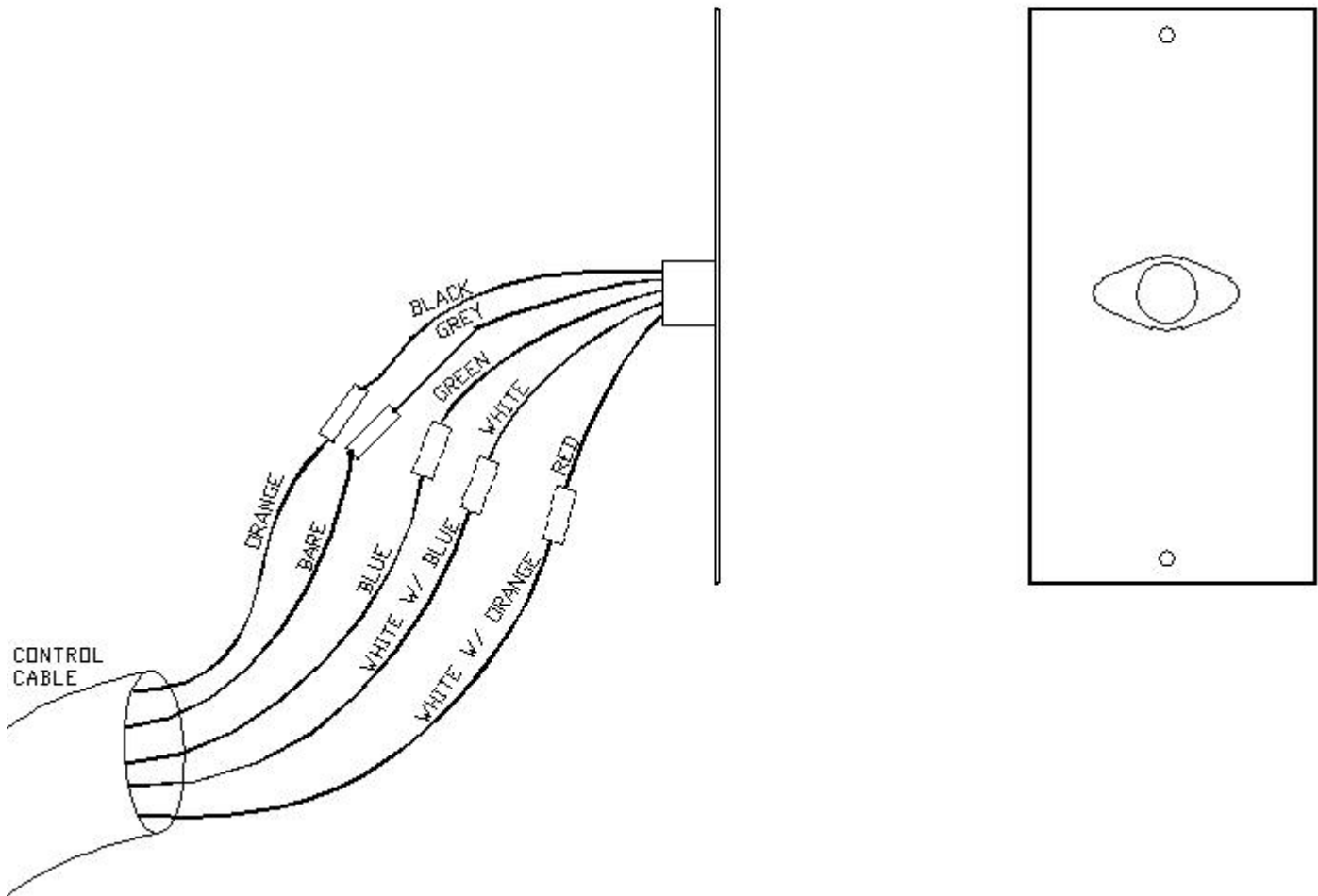

2. The back of the wall plate has a label indicating how the connections are to be made. As follows connect the black wire on the wall plate to the orange wire, connect the gray wire on the wall plate to the bare (shield) wire in the cable, connect the green wire on the wall plate to the blue wire of the cable, connect the white wire of the wall plate to the white with a blue stripe of the cable. **This is for a hand held controller only to connect the red wire to the white with orange stripe wire of the cable.** To prevent confusion it is recommended to have purchased the cable with the scoreboard, other cable may not be suitable for the installation giving false errors or communication problems between the controller and the scoreboard.

3. Secure the junction box cover to the installed junction box.

At the scoreboard:

4. Remove the signal/power access door located on the back of panel A.

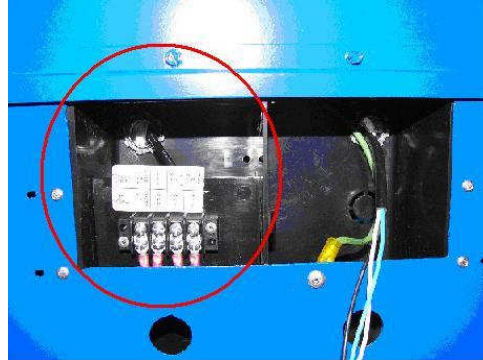

5. From the ground, run the control cable through a sealed, water-tight conduit then through a water-tight conduit fitting into the left side of the signal cable/power access door and into the scoreboard. A hole is provided for a conduit connector
6. Inside the scoreboard, connect the control cable leads to the appropriate terminals on the terminal block, according to the label above the terminal block. The connections are as follows connect the orange and bare wire of the cable to the terminal block opposite the black & gray wire connection, connect the blue wire of the cable to the terminal block opposite the green wire connection, connect the white with blue stripe of the cable to the terminal opposite the white wire connection. Do not connect the white with the orange stripe of the cable UNLESS YOU ARE USING A HAND HELD CONTROLLER THIS CONNECTION WILL HAVE TO BE MADE AS FOLLOWS: Connect the white with orange stripe of the cable the terminal opposite the red wire connection. MAKING THIS CONNECTION USING A LARGE CONTROLLER WILL BURN THE CONTROLLER OUT. If you need assistance call 800-411-3136.

# SIGNAL/POWER ACCESS DOOR ON SCOREBOARD

WIRE FROM  
SCOREKEEPERS  
LOCATION

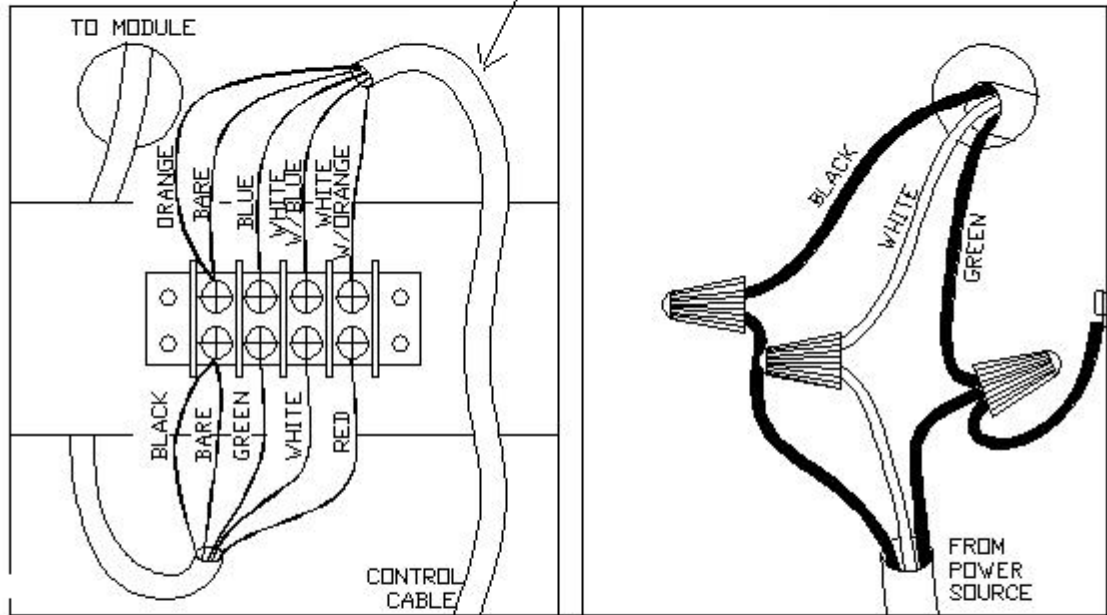

7.

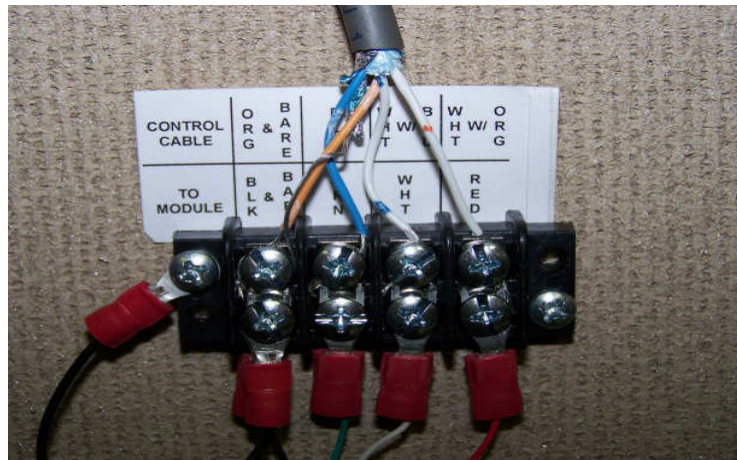

**NOTE: Refer to the connections that were made at the scorekeeper's location. Make the connections at the scoreboard match the connections at the scorekeeper's location.**

8. Re-secure the signal/power access door to the scoreboard.

## RUNNING & CONNECTING THE ELECTRIC SERVICE

**NOTE: IT IS RECOMMENDED TO HAVE A LICENSED ELECTRICIAN FOR THIS PORTION. IDEALLY, THE SCOREBOARD WILL BE POWERED FROM A DEDICATED 120-VOLT / 20 AMP CIRCUIT. ADDITIONALLY, SINCE THE SCOREBOARD'S POWER SHOULD BE TURNED OFF AFTER EACH USE, THERE SHOULD BE EASY ACCESS TO THE POWER SWITCH OR CIRCUIT BREAKER. IF ACCESS TO THE CIRCUIT BREAKER IS NOT AN OPTION, INSTALL A SWITCH SOMEWHERE THAT IS ACCESSIBLE, EVEN IF UNDER THE SCOREBOARD AT AN ABOVE AVERAGE HEIGHT.**

1. The scoreboard has a  $\frac{1}{2}$ " knock-out on the lower right corner for bringing in the electrical service. It can be enlarged if the conduit size is  $\frac{3}{4}$ ". This is where the conduit from the power source needs to terminate.

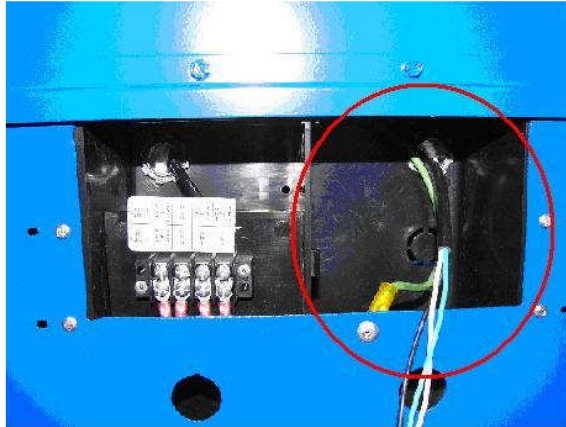

2. The connections are standard black, white, and green (ground). Replace the cover when complete.

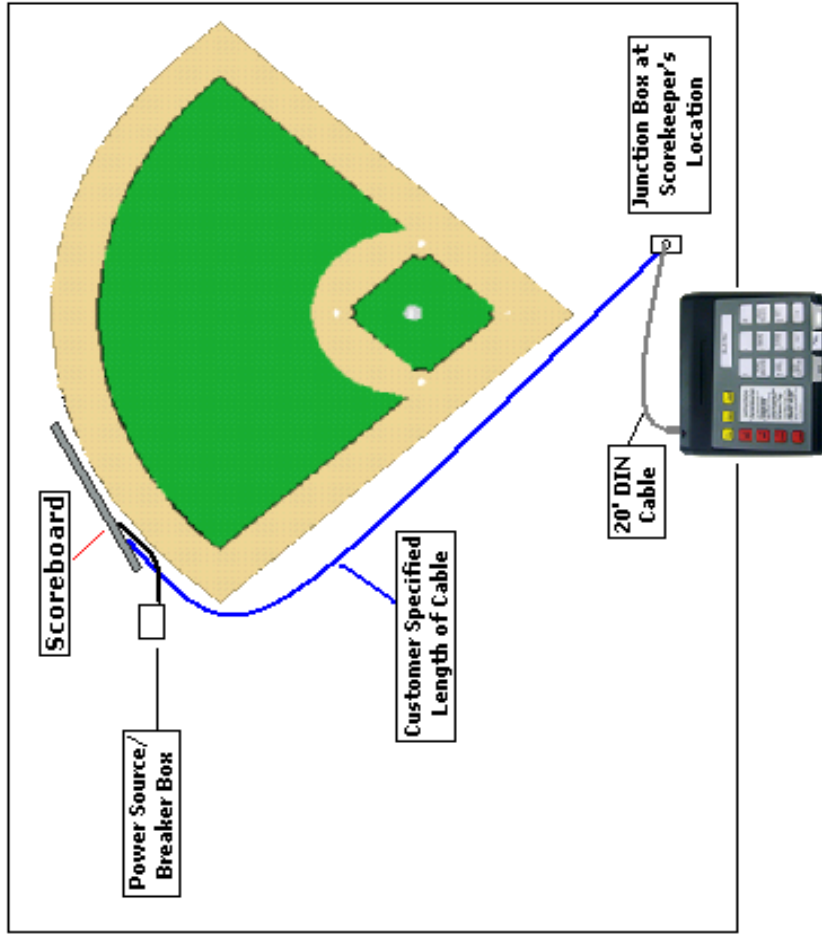
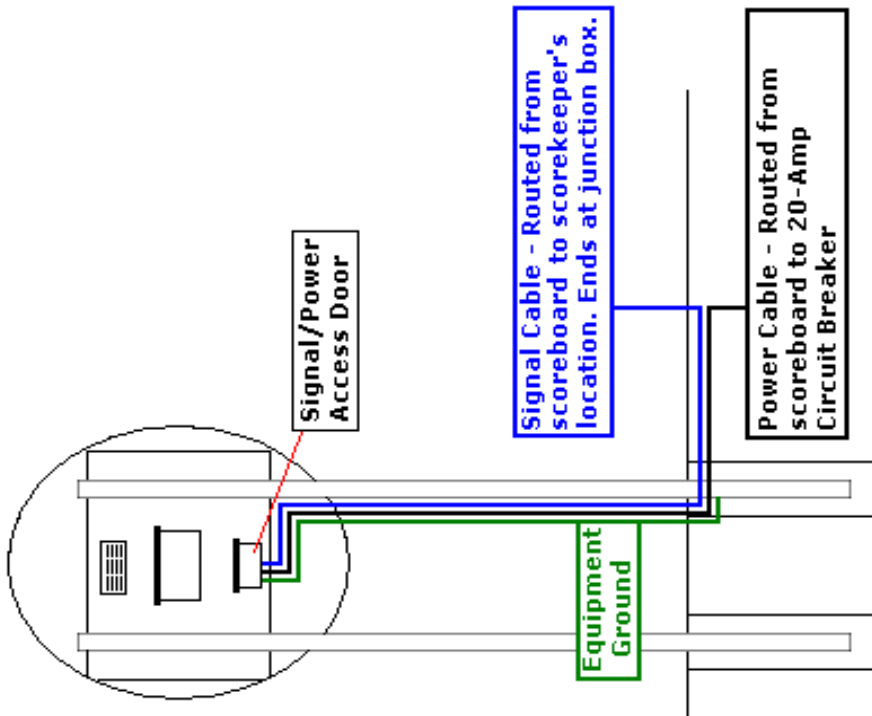

**IMPORTANT, PLEASE NOTE:**

1. Electrical connections should be performed by a licensed, qualified electrician in accordance with the product specifications, this diagram, and all building and electrical codes that apply to your area.
2. A water-tight, non-fusible disconnect with a 20-amp ground fault interrupt with equipment ground should be installed for each 20-amp circuit connected to the scoreboard.

## Testing the scoreboard system:

1. Connect the appropriate end of the 12-volt DC wall transformer to the power receptacle on the back of the controller. Plug the transformer into a live, 120-volt outlet. If the optional battery pack was purchased with the keyboard, the transformer is also used to charge the battery.
2. Turn the power to the scoreboard *ON* using the power disconnect switch or circuit breaker. The **HOME** and **GUEST** scores should read “0”, and **QTR** should read “1”, and the clock should show the default time..
3. With the controller *OFF*, press and hold the **OPTION** key while turning the controller *ON*. The controller’s LCD will briefly display the controller’s software version. When the display changes and reads “**SELECT DIAG MODE <DIGIT TEST>**” press **ENTER**. The LCD will now read “**SEGMENT TEST – SEGMENTS OFF.**”
  - a. **NOTE: None of the scoreboards components should be lit at this time. If any components are lit, especially with a solid “8”, check the crossover connections between cabinets. Ensure that the red stripes on the ribbon cables are matched where they are connected.**
4. Pressing the **UP** arrow (located on the far right of the controller’s keypad) will cycle the scoreboard into “digit count” mode and all displays on the scoreboard will count 0-9 repetitively. Pressing the **UP** arrow again will cycle to “**<ALL ON>**”, and all components should display an “8”. At this time, take a look at the segments of each component for LEDs that are not lit.
5. To exit the diagnostic mode, press the **RESET** key twice.
6. If all components pass this test, the installation is complete.

**NOTE:** Always turn both the controller and the scoreboard *OFF* after each use. If the controller is turned *OFF* but the scoreboard remains *ON*, (or if the controller loses communication with the scoreboard), the scoreboard’s *STRIKE* digit will begin to flash. This feature is intended to remind the user to turn power to the scoreboard *OFF* after each use.

## IMPORTANT!

### Warranty Activation/Installation & Completion Sign Off Sheet

NOTE: This sheet must be completely filled out and returned/faxed (270) 753-3773 to Scoreboard Service Company before your warranty can be activated.

Your Serial Number \_\_\_\_\_

Your Model Number \_\_\_\_\_

Date Purchased \_\_\_\_\_

Sales Agent \_\_\_\_\_

Person Authorizing Purchase (title) \_\_\_\_\_

Date Installation Completed \_\_\_\_\_

Company or Person Responsible  
For Installation (address/phone number) \_\_\_\_\_

---

This document confirms that the installation for the 4-ft.x 8-ft. Football Scoreboard has been completed. All structural, wiring, and power requirements have been met. This unit has been tested in scoring and diagnostic modes, ensuring the functionality of the unit.

\_\_\_\_\_  
Scoring/timing equipment responsible party

\_\_\_\_\_  
Installer

So that we may better serve you, please have this information available in the event you need to call technical support. Customer Service: 1-800-411-3136