

# MODEL 2850 CONTROL VALVE

---

*Service Manual*

---

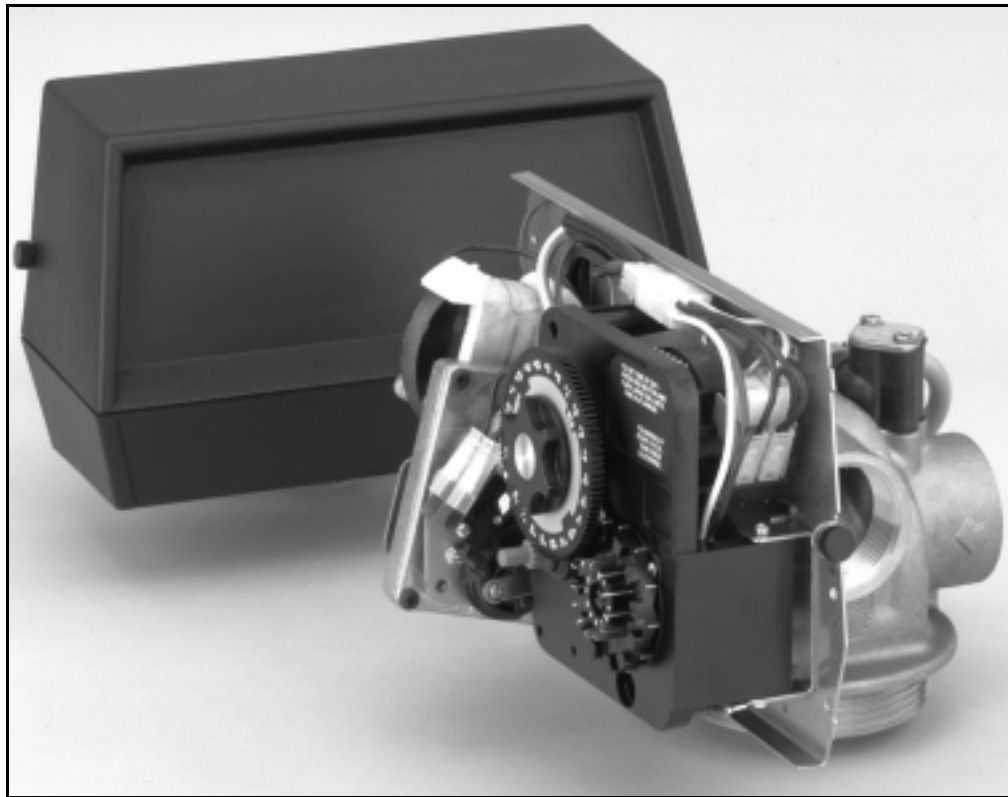

**IMPORTANT:** Fill in pertinent information on page 2 for future reference.

# MODEL 2850

## Job Specification Sheet

---

\* JOB NO. \_\_\_\_\_

\* MODEL NO. \_\_\_\_\_

\* WATER TEST \_\_\_\_\_

\* CAPACITY PER UNIT \_\_\_\_\_

\* MINERAL TANK SIZE DIA. \_\_\_\_\_ HEIGHT \_\_\_\_\_

\* BRINE TANK SIZE & SALT SETTING PER REGENERATION:  
\_\_\_\_\_

### \* 2850 CONTROL VALVE SPECIFICATIONS

1) Type of Timer (see pages 16,17, and 18)

A) 7 day or 12 day

B) \* 625 to 10,625 gallon meter or

\* 3,125 to 53,125 gallon meter

\* Other \_\_\_\_\_

C) Meter Wiring Package

1) System #4 - 1 tank; 1 meter; immediate or delayed regeneration

2) System #5 - 2 tanks; 2 meters; interlock

3) System #6 - 2 tanks; 1 meter; series regeneration

4) System #7 - 2 tanks; 1 meter; alternator

2) Timer Program Settings (see page 18)

A) Backwash \_\_\_\_\_ min.

B) Brine & Slow Rinse \_\_\_\_\_ min.

C) Rapid Rinse \_\_\_\_\_ min.

D) Brine Tank Refill \_\_\_\_\_ min.

3) Drain Line Flow Control \_\_\_\_\_ gpm

4) Brine Line Flow Controller \_\_\_\_\_ gpm

5) Injector Size # \_\_\_\_\_

6) Service Valve Operation Units (SVO)

Size of Service Valve \_\_\_\_\_

# MODEL 2850

---

## *General Commercial Pre-Installation Check List*

---

**WATER PRESSURE:** A minimum of 25 pounds of water pressure is required for regeneration valve to operate effectively.

**ELECTRICAL FACILITIES:** A continuous 115 volt, 60 Hertz current supply is required. Make certain the current supply is always hot and cannot be turned off with another switch.

**EXISTING PLUMBING:** Condition of existing plumbing should be free from lime and iron buildup. Piping that is built up heavily with lime and/or iron should be replaced. If piping is clogged with iron, a separate iron filter unit should be installed ahead of the water softener.

**LOCATION OF SOFTENER AND DRAIN:** The softener should be located close to a drain.

**BY-PASS VALVES:** Always provide for the installation of a by-pass valve.

**CAUTION:** Water pressure is not to exceed 120 p.s.i., water temperature is not to exceed 100° F, and the unit cannot be subjected to freezing conditions.

---

## *Installation Instructions*

---

1. Place the softener tank where you want to install the unit making sure the unit is level and on a firm base. (Maximum 4 feet apart for twin units.)
2. All plumbing should be done in accordance with local plumbing codes. The pipe size for the drain line should be the same size as the drain line flow control connection. Water meters are to be installed on soft water outlets. Twin units with (1) one meter shall be installed on common soft water outlet of units.
3. Solder joints near the drain must be done prior to connecting the Drain Line Flow Control fitting. Leave at least 6" between the DLFC and solder joints when soldering when the pipes are connected on the DLFC. Failure to do this could cause interior damage to the DLFC.
4. Teflon tape is the only sealant to be used on the drain fitting. The drain from twin units may be run through a common line.
5. Make sure that the floor is clean beneath the salt storage tank and that it is level.
6. Place approximately 1" of water above the grid plate (if used) in your salt tank. Salt may be placed in the unit at this time.
7. Place in by-pass position. Turn on the main water supply. Open a cold soft water tap nearby and let run a few minutes or until the system is free from foreign material (usually solder) that may have resulted from the installation.
8. Place the by-pass in service position.
9. Manually index the softener control into "service" position and let water flow into the mineral tank. When water flow stops, close inlet valve, place control in "backwash" position to relieve head of air, then gradually open inlet valve to purge remaining air in tank. Return control to service position.
10. Electrical: All electrical connections must be connected according to codes. Use electrical conduit if applicable. Plug into power supply.

# MODEL 2850

## Water Conditioner Flow Diagrams

### 1 SERVICE POSITION

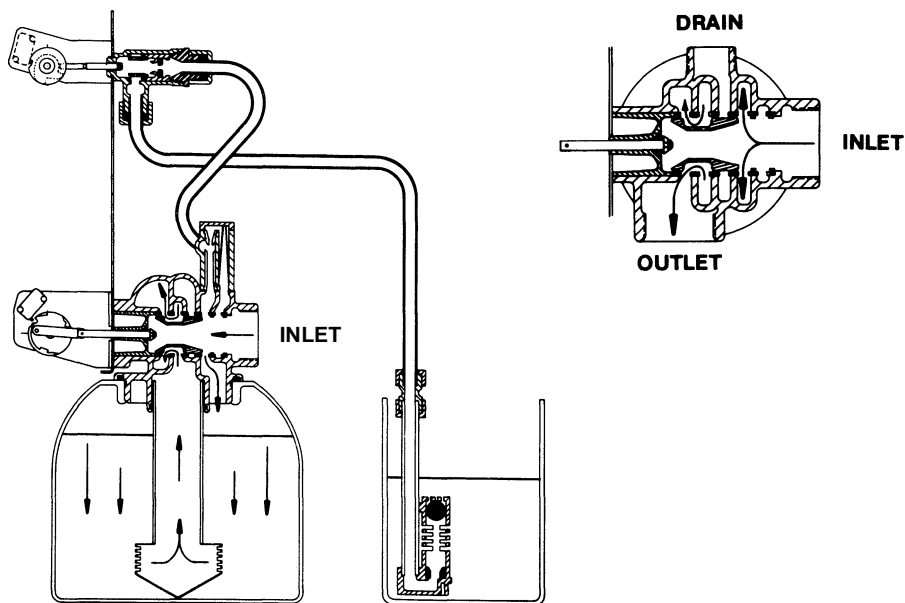

Hard water enters unit at valve inlet and flows down thru the mineral in the mineral tank. Conditioned water enters center tube thru the bottom distributor — then flows up thru the center tube — around the piston and out the outlet of the valve.

### 2 BACKWASH POSITION

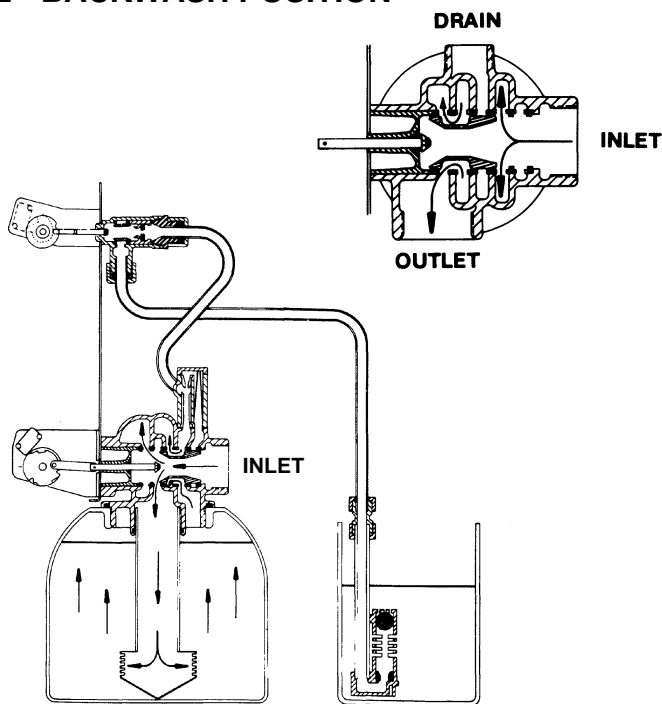

Hard water enters unit at valve inlet — flows thru piston — down center tube — thru bottom distributor and up thru the mineral — around the piston and out the drain line.

### 3 BRINE POSITION

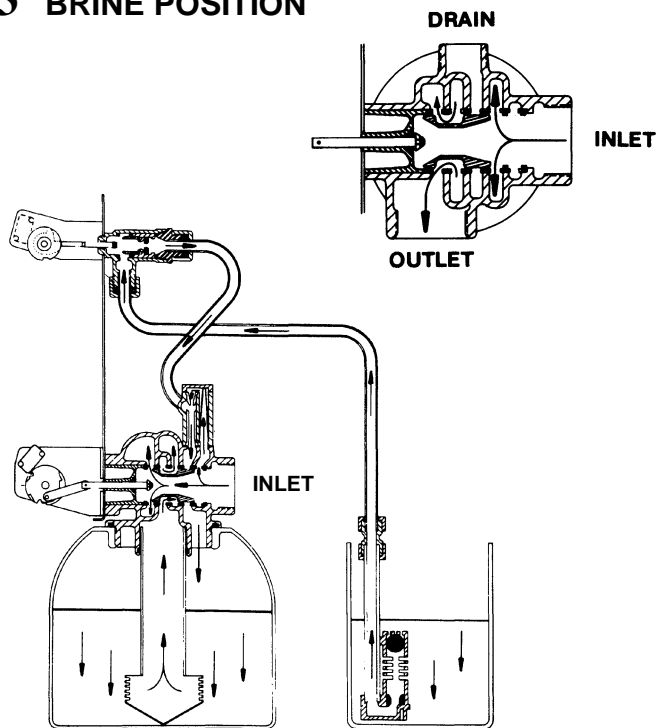

Hard water enters unit at valve inlet — flows up into injector housing and down thru nozzle and throat to draw brine from the brine tank — brine flows down thru mineral and enters the center tube thru bottom distributor and out thru the drain line.

# MODEL 2850

## Water Conditioner Flow Diagrams (Cont'd.)

### 4 SLOW RINSE POSITION

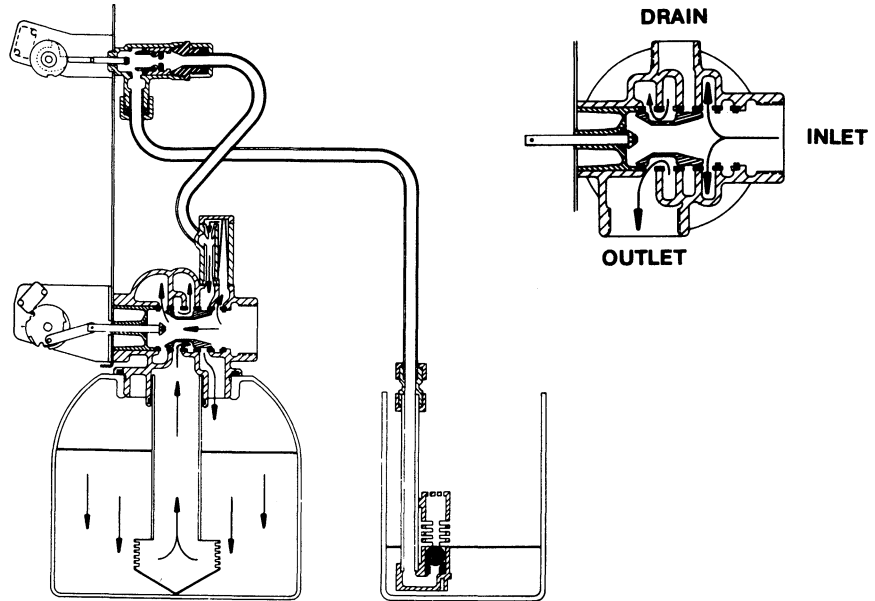

Hard water enters unit at valve inlet — flows up into injector housing and down thru nozzle and throat — around the piston — down thru mineral — enters center tube thru bottom distributor — flows up thru center tube — around piston and out thru drain line.

### 5 RAPID RINSE

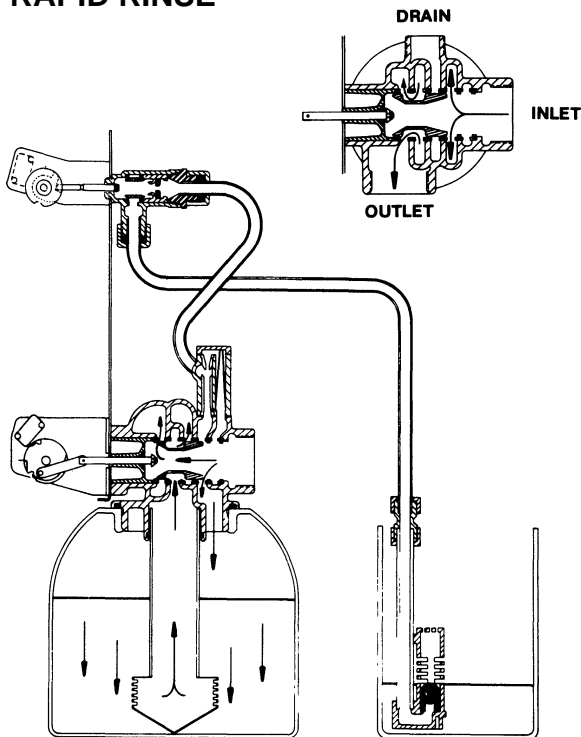

Hard water enters unit at valve inlet — flows directly from inlet down thru mineral into center tube bottom distributor and up thru center tube — around piston and out thru the drain line.

### 6 BRINE TANK REFILL POSITION

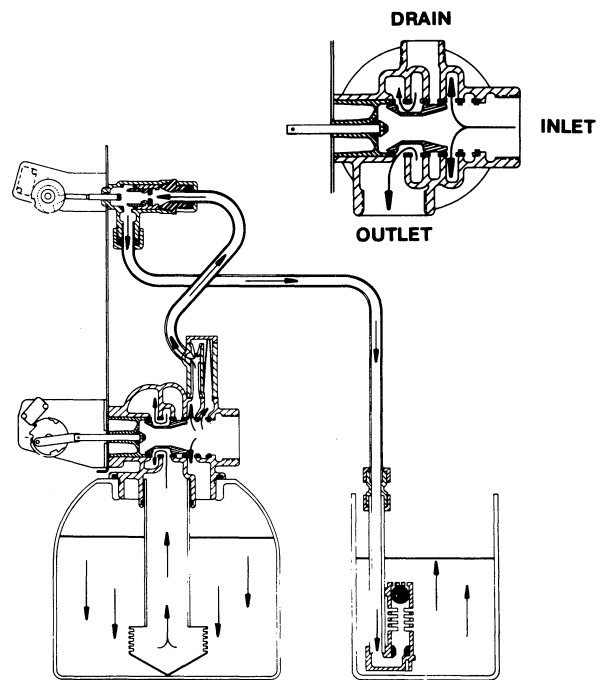

Hard water enters unit at valve inlet — flows up thru the injector housing — thru the brine valve to refill the brine tank.

# MODEL 2850

## Control Valve with 1700 Injector

(See Opposite Page for Parts List)

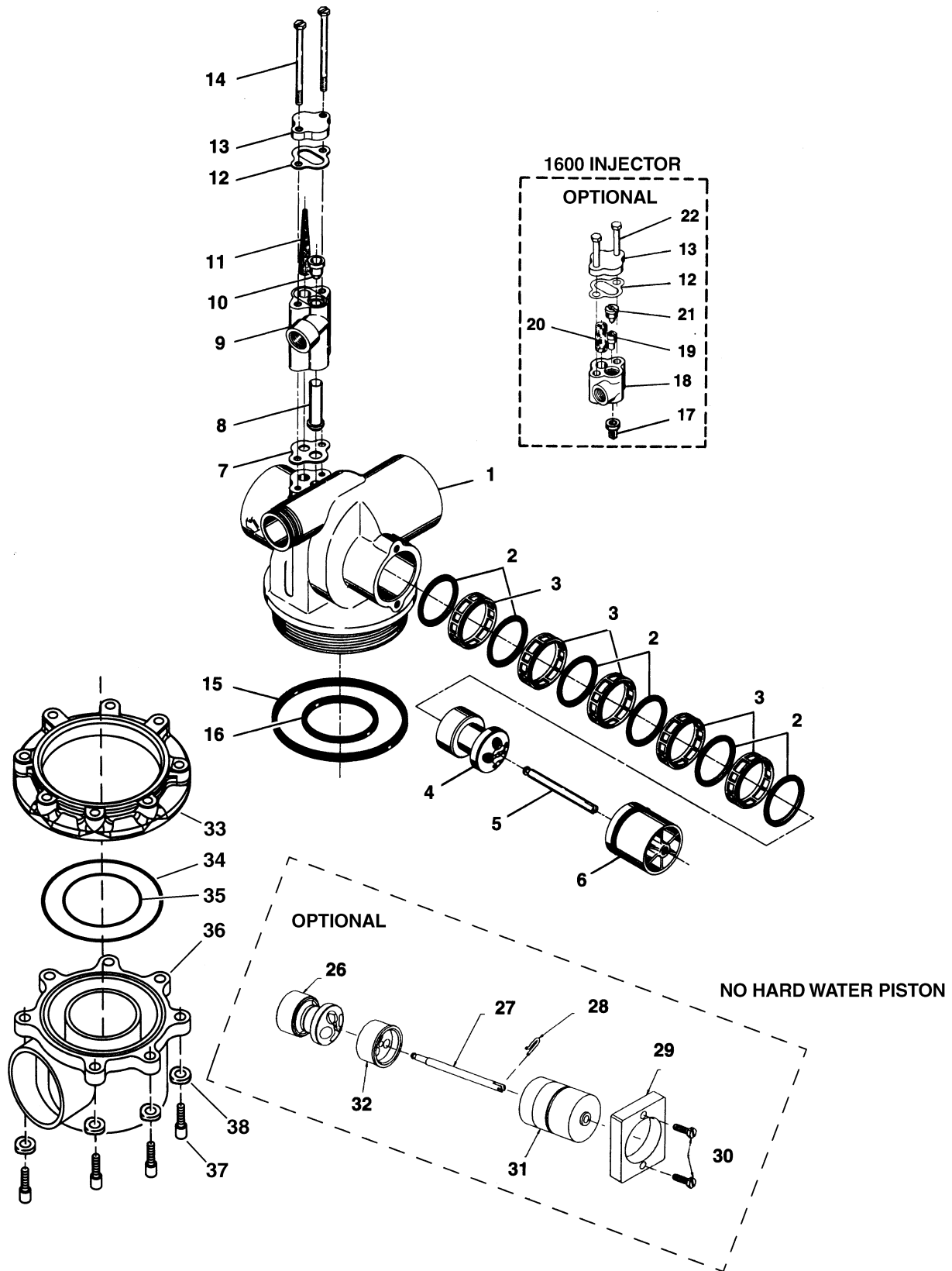

# MODEL 2850

## Control Valve with 1700 Injector

### Parts List

Item No.	Quantity	Part No.	Description
1	1	16250	Valve Body
		16250-01	Valve Body Machined
2	6	16101	Seal
		16101-02	Silicone Seals
3	5	16638-01	Spacer
	1	16638	Spacer, Hot Water
4	1	16092	Piston
5	1	16436	Piston Rod
6	1	16395	End Plug Assembly
	1	16395-01	End Plug Assembly, Hot Water
7	1	14805	Injector Body Gasket
8	1	14802	Injector Throat
9	1	17777	Injector Body
10	1	14801	Injector Nozzle
11	1	14803	Injector Screen
12	1	10229	Injector Cover Gasket
13	1	11893	Injector Cover
14	2	14804	Screw - Injector Body
15	1	16455	O-Ring - Top of Tank
*16	1	13577	O-Ring
17	1	16221	Air Disperser
18	1	17776	Injector Body
19	1	10914	Injector Throat
20	1	10227	Injector Screen
21	1	10913	Injector Nozzle
22	2	10692	Screw - Injector Body
		17656	Screw, Metric - Injector Body
23	1	60366	DLFC 1" NPT (not shown) - specify size
24	1	17996	Air Disperser, 1700 (not shown)
25	1	19608-15	Disperser, Upper (not shown)
26	1	19606	Piston
27	1	19300	NHWP-P Piston Rod
28	1	10909	Connecting Link Pin
29	1	19339	NHWP-P Spacer
30	2	13386	Screw
31	1	16395-02	NHWP-P End Plug Assy.
32	1	19298-01	NHWP-P Piston Assy.
<b>Optional Side Mount</b>			
33	1	40316	Side Mount Adapter
34	1	40368	O-Ring, 2-160
35	1	40372	O-Ring, 2-142
36	1	40310	Base, Rotating
37	7	19768	Screw, Adapter
38	7	40375	Washer

\* Do not use O-Ring if control is side mounted.

# MODEL 2850

## Control Drive Assembly

(See Opposite Page for Parts List)

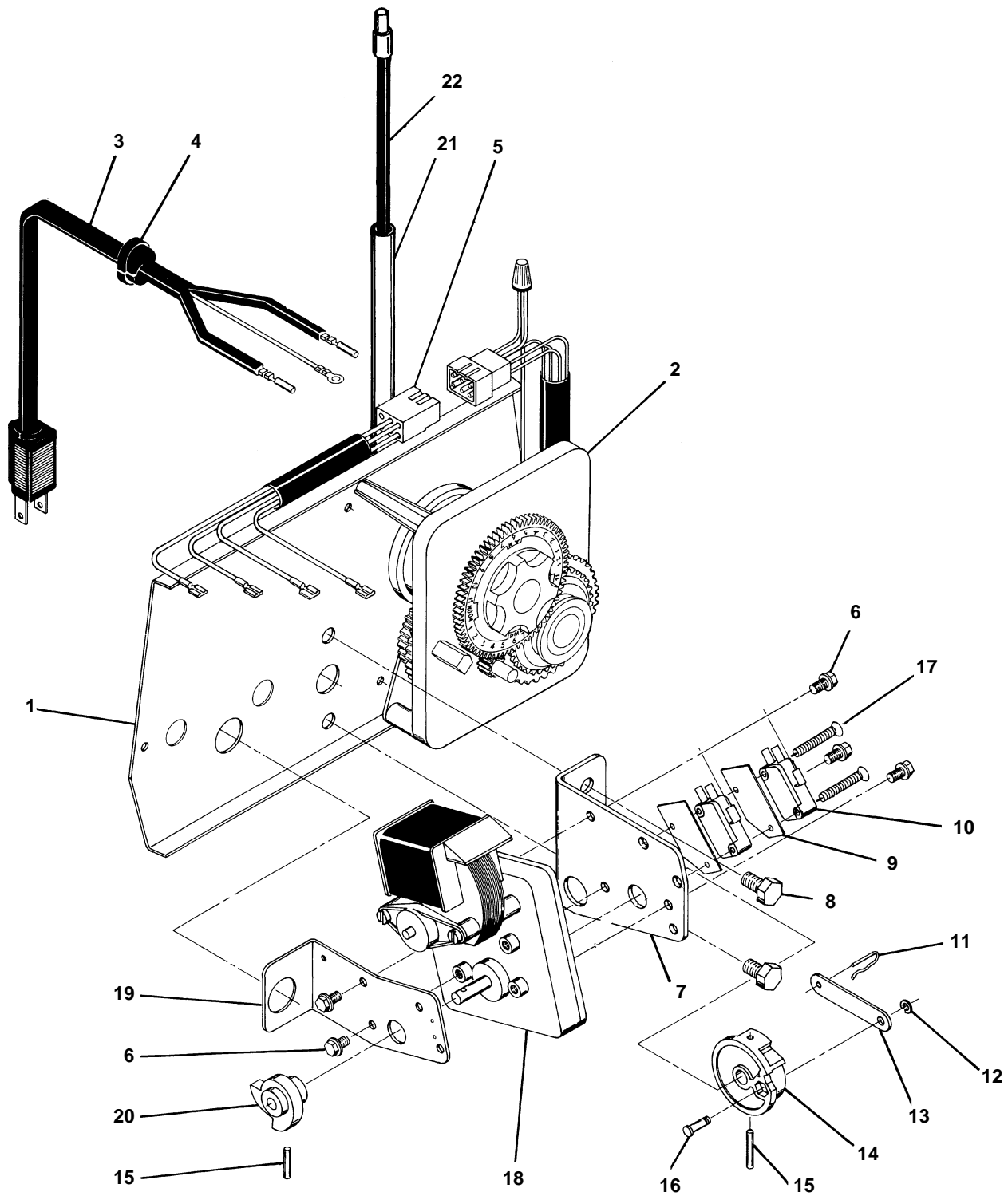



# MODEL 2850

## Control Drive Assembly

### Parts List

Item No.	Quantity	Part No.	Description
1.....	1	40264	Back Plate w/ Thumb Screws
2.....	1		Timer - 3200 7 Day - 3200 12 Day - 3210 Meter
3.....	1	11838	Power Cord
4.....	1	13547	Strain Relief
5.....	1	11667	Wire Harness
6.....	5	10872	Screw - Motor Mounting
7.....	1	10774	Bracket - Motor Mounting
8.....	2	10231	Screw - Drive Mounting
9.....	2	10302	Insulator
10.....	2	10218	Switch
11.....	1	10909	Connecting Link Pin
12.....	1	10250	Retaining Ring
13.....	1	10621	Connecting Link
14.....	1	12576	Drive Cam - STF (Black)
	1	12102	Drive Cam - RR (White)
15.....	2	10338	Roll Pin
16.....	1	13366	Drive Bearing
17.....	2	14923	Screw - Switch Mounting
18.....	1	10769	Motor
19.....	1	11826	Bracket - Brine Valve Side
20.....	1	12777	Brine Valve Cam - STF (Black)
	1	10815	Brine Valve Cam - RR (White)
	1	12472	Brine Valve Cam - SVO (not shown)*
21.....	1	17470	Meter Cable Guide Assembly
22.....	1	17741	Meter Cable Assembly
23.....	2	10300	Screw - Timer Mounting (not shown)
24.....	1	12114	Outboard Bearing Bracket (not shown)*
25.....	2	15742	Screw (not shown)
26.....	2	15833	Spacer (not shown)
27.....	1	19291-020	Cover, 1-piece Black, (not shown)
28.....	2	19367	Screw, Cover (not shown)

# MODEL 2850 ECONOMINDER®

## Timer Assembly

(See Opposite Page for Parts List)

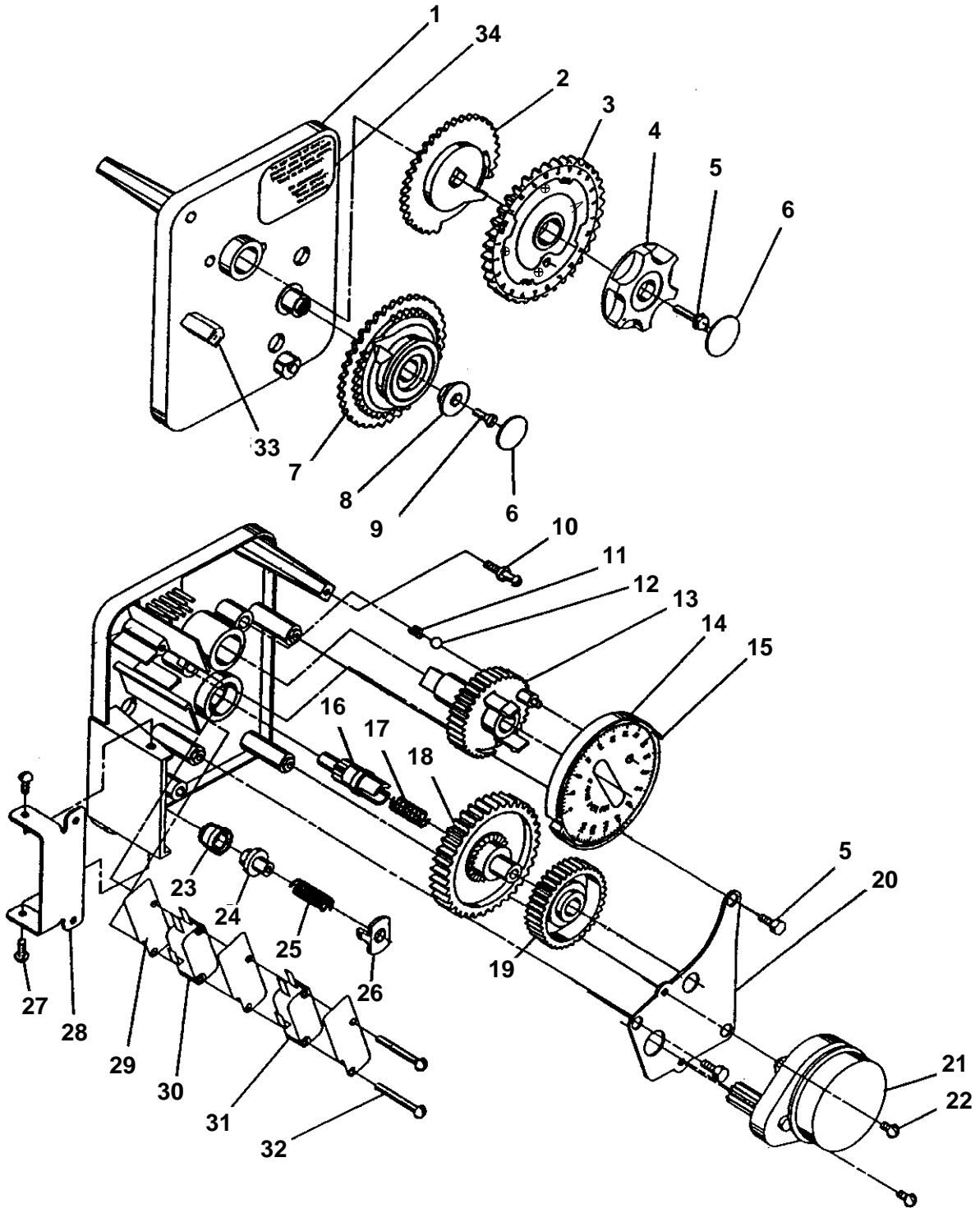

# MODEL 2850 ECONOMINDER®

## Timer Assembly

### Parts List

Item No.	Quantity	Part No.	Description
1	1	13870-01	Timer Housing Assembly
2	1	13802	Cycle Actuator Gear
3	1	40096-24	24 Hour Gear Assembly, 12 Midnight
		40096-02	24 Hour Gear Assembly, 2 a.m.
4	1	13886-01	Knob
5	4	13296	Screw - Timer Knob and Motor Plate Mtg.
6	2	11999	Button Decal
7	1	60405-15	Program Wheel Assy. (Specify Hardness Capacity)
8	1	13806	Program Wheel Retainer
9	1	13748	Screw - Program Wheel Mtg.
10	1	14265	Spring Clip
11	1	15424	Spring - Detent
12	1	15066	Ball - 1/4 in. Dia.
13	1	13911	Main Drive Gear
14	1	19210	Program Wheel
15	21	15493	Roll Pin
16	1	13018	Idler Shaft
17	1	13312	Spring - Idler
18	1	13017	Idler Gear
19	1	13164	Drive Gear
20	1	13887	Motor Mounting Plate
21	1	18743	Motor - 120V., 60 Hz.
		19659	Motor - 24V., 60 Hz.
22	2	13278	Screw, Motor Mounting
23	1	13830	Drive Pinion - Program Wheel
24	1	13831	Clutch - Drive Pinion
25	1	14276	Spring
26	1	14253	Spring Retainer
27	3	11384	Screw - Timer Hinge and Ground Wire
28	1	13881	Hinge Bracket
29	3	14087	Insulator
30	1	10896	Switch
31	1	15320	Switch
32	2	11413	Screw - Switch Mounting
33	1	14007	Decal - Time of Day
34	1	14045	Decal - Instructions
Not Shown	1	13902	Harness
Not Shown	2	12681	Wire Connector
Not Shown	1	15354-01	Ground Wire 17748-01 F.E

# MODEL 2850

## Manual Drive Assembly

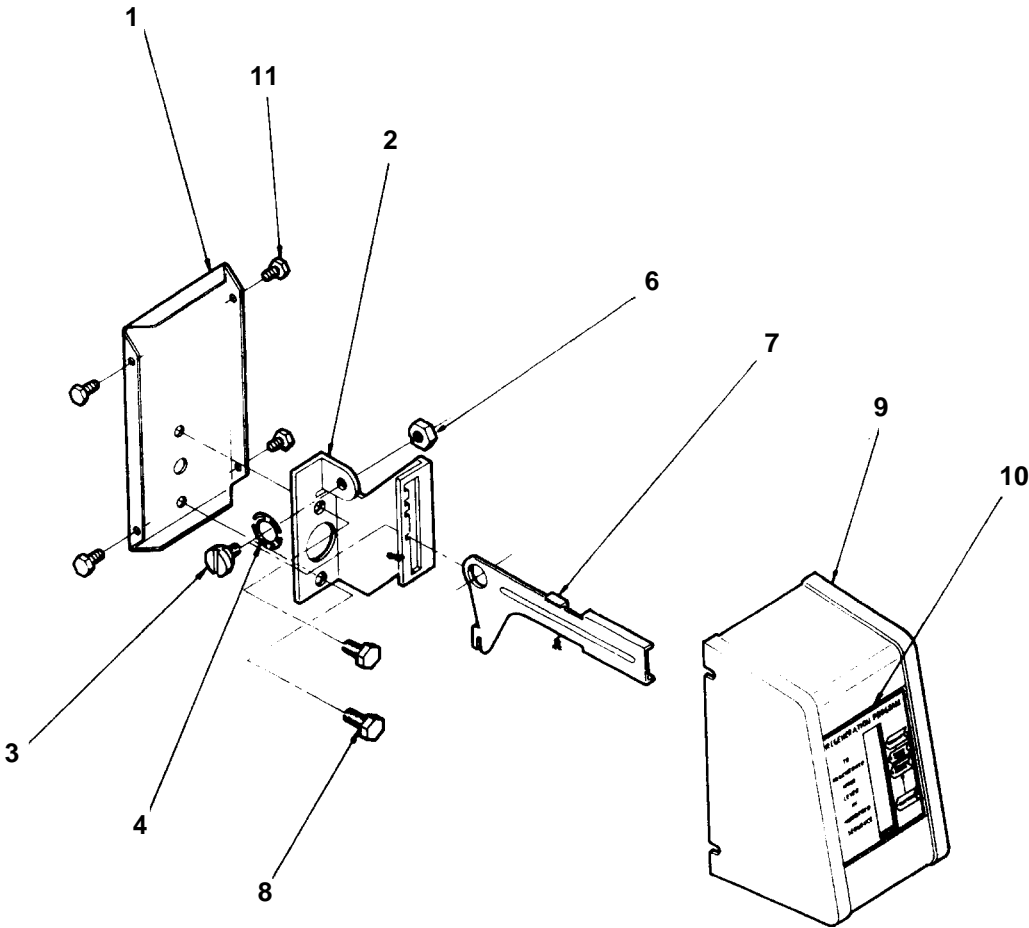

# MODEL 2850

---

## *Manual Drive Assembly*

---

### *Parts List*

---

<b>Item No.</b>	<b>Quantity</b>	<b>Part No.</b>	<b>Description</b>
1.....	1 .....	12593 .....	Back Plate
2.....	1 .....	12592 .....	Lever Position Bracket
3.....	1 .....	12596 .....	Pivot Screw
4.....	1 .....	12707 .....	Spring Washer
5.....	1 .....	10909 .....	Pin, Link (Not Shown)
6.....	1 .....	11235 .....	Nut
7.....	1 .....	12594 .....	Valve Position Lever
8.....	2 .....	10231 .....	Screw - Valve Mounting
9.....	1 .....	60224 .....	Cover Assembly
10 .....	1 .....	12597 .....	Valve Position Label - Softener
	1 .....	14219 .....	Valve Position Label - Filter
11 .....	4 .....	10300 .....	Screw - Cover Mounting

# MODEL 2850

## *No Hard Water Bypass Piston Assembly*

*(See opposite page for parts list)*

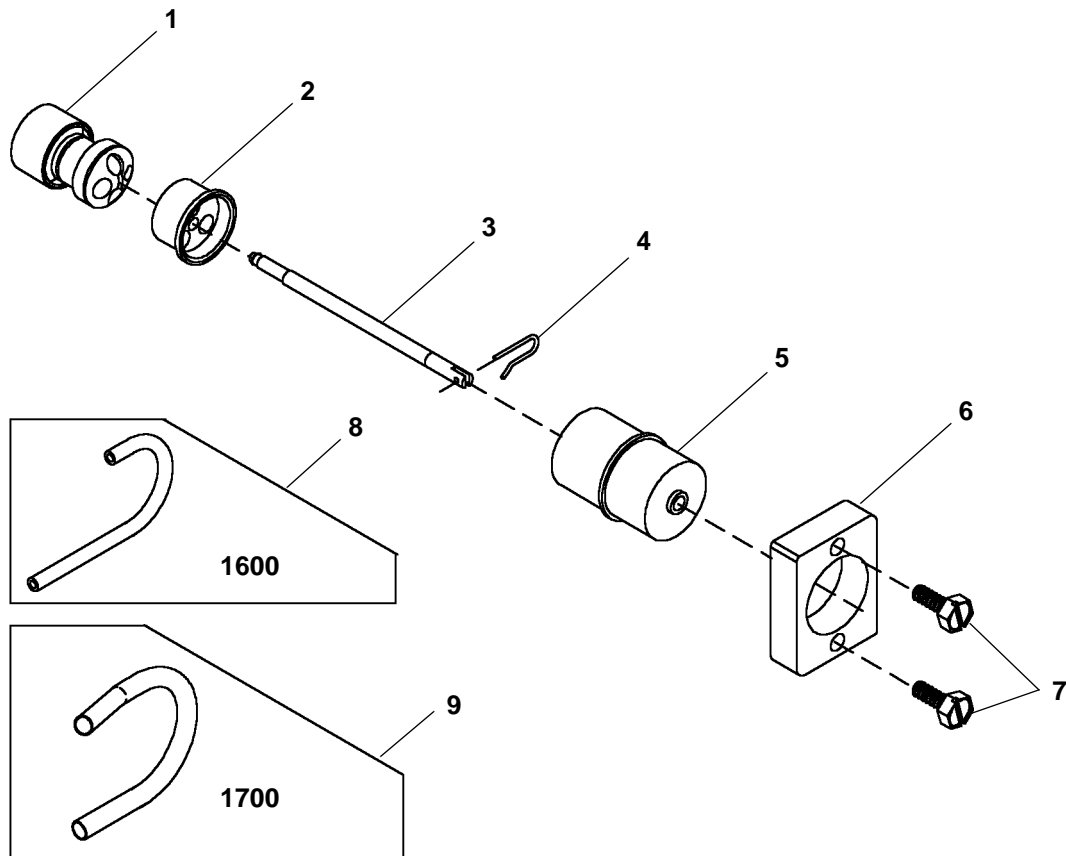

# MODEL 2850

## No Hard Water Bypass Piston Assembly

### Parts List

Item No.	Quantity	Part No.	Description
1.....	1 .....	19606 .....	Piston, 2850, No Hard Water Bypass
2.....	1 .....	19298-01.....	Piston Assy. No Hard Water Bypass
	1 .....	19298 .....	Piston, 2850 Bypass
	1 .....	19312 .....	O-Ring, -025
3.....	1 .....	19300 .....	NHWP-P Piston Rod
4.....	1 .....	10909 .....	Pin, Link
5.....	1 .....	16395-02.....	End Plug Assy., No Hard Water Bypass
	1 .....	19302 .....	End Plug
	1 .....	16394 .....	O-Ring
	1 .....	13008 .....	Retainer
	1 .....	10209 .....	Quad
6.....	1 .....	19339 .....	Spacer, No Hard Water Bypass
7.....	2 .....	13386 .....	Screw, Hex Hd. 1/4-20 x 1"
8.....	1 .....	19337 .....	Brine Tube, 1600, No Hard Water Bypass
	2 .....	10329 .....	Nut, 3/8
	2 .....	10330 .....	Sleeve, 3/8"
	2 .....	10332 .....	Insert, 3/8"
9.....	1 .....	19338 .....	Tube
	2 .....	15414 .....	Nut

### Options

1 .....	60114-00.....	Filter, Piston Conv. to No Hard Water Bypass Std.
1 .....	60114-01.....	Piston Assy., Replacement
1 .....	60114-02.....	No Hard Water Bypass Conc., 1600
1 .....	60114-03.....	No Hard Water Bypass Conc., 1700

# MODEL 3210 ECONOMINDER®

## Commercial Demand Regeneration Control Timer Settings

### Typical Programming Procedure

Calculate the gallon capacity of the system, subtract the necessary reserve requirement and set the gallons required by lifting the gallon dial and rotating it so that the number of gallons required is aligned with the white dot on program wheel gear. Release and check for firm engagement with gear.

**Note:** To set meter capacity at initial start-up, either:

1. Rotate manual regeneration knob one full revolution.  
— or —
2. Rotate program wheel manually clockwise and align white dot with capacity arrow.

This procedure must be followed any time the program wheel setting is changed.

### How To Set The Time Of Day:

Press and hold the red button in to disengage the 24 hour gear.

Turn the 24 hour gear until the actual time of day is at the time of day pointer.

Release the red button to again engage the 24 hour gear.

### How To Manually Regenerate Your Water Condition At Any Time:

Turn the manual regeneration knob clockwise one "click".

This slight movement of the manual regeneration knob engages the program wheel and starts the regeneration program.

The black center knob will make one revolution in the following approximately three hours and stop in the position shown in the drawing.

Even though it takes three hours for this center knob to complete one revolution, the regeneration cycle of your unit might be set for only one half of this time.

In any event, conditioned water may be drawn after rinse water stops flowing from the water conditioner drain line.

### Immediate Regeneration Timers:

These timers do not have a 24 hour gear. Setting the gallons on the program wheel and manual regeneration procedure are the same as previous instructions.

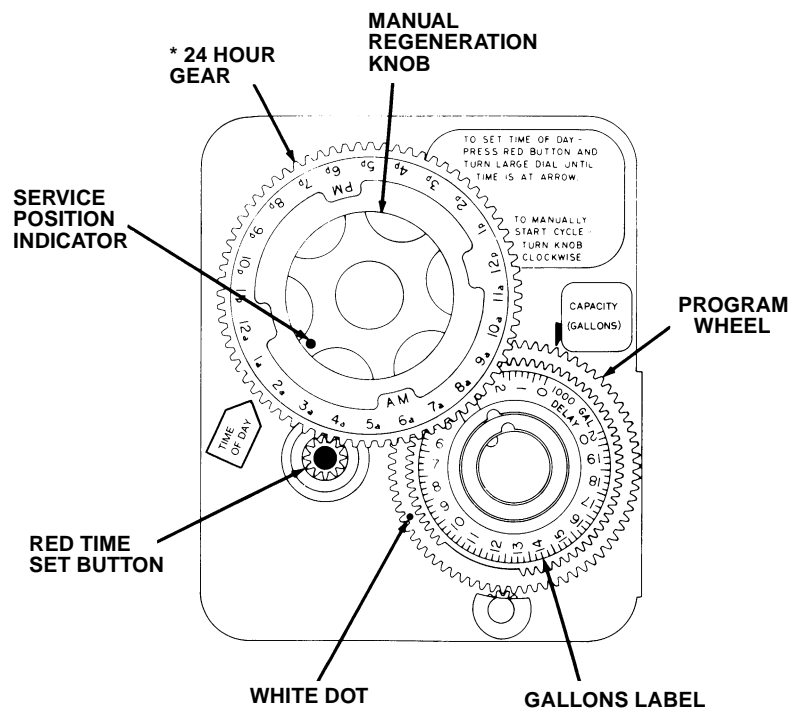

\* Immediate regeneration times do not have 24 hour gear. No time of day can be set.



# MODEL 3200 TIMER

## Timer Setting Procedure

### How To Set Days On Which Water Conditioner Is To Regenerate:

Rotate the skipper wheel until the number "1" is at the red pointer. Set the days that regeneration is to occur by sliding tabs on the skipper wheel outward to expose trip fingers. Each tab is one day. Finger at red pointer is tonight. Moving clockwise from the red pointer, extend or retract fingers to obtain the desired regeneration schedule.

### How To Set The Time Of Day:

Press and hold the red button in to disengage the drive gear. Turn the large gear until the actual time of day is at the time of day pointer. Release the red button to again engage the drive gear.

### How To Manually Regenerate Your Water Conditioner At Any Time:

Turn the manual regeneration knob clockwise. This slight movement of the manual regeneration knob engages the program wheel and starts the regeneration program.

The black center knob will make one revolution in the following approximately three hours and stop in the position shown in the drawing.

Even though it takes three hours for this center knob to complete one revolution, the regeneration cycle of your unit might be set only one half of this time.

In any event, conditioned water may be drawn after rinse water stops flowing from the water conditioner drain line.

### How to Adjust Regeneration Time:

1. Disconnect the power source.
2. Locate the three screws behind the manual regeneration knob by pushing the red button in and rotating the 24 hour dial until each screw appears in the cut out portion of the manual regeneration knob.
3. Loosen each screw slightly to release the pressure on the time plate from the 24 hour gear.
4. Locate the regeneration time pointer on the inside of the 24 hour dial in the cut out.
5. Turn the time plate so the desired regeneration time aligns next to the raised arrow.
6. Push the red button in and rotate the 24 hour dial. Tighten each of the three screws.
7. Push the red button and locate the pointer one more time to ensure the desired regeneration time is correct.
8. Reset the time of day and restore power to the unit.

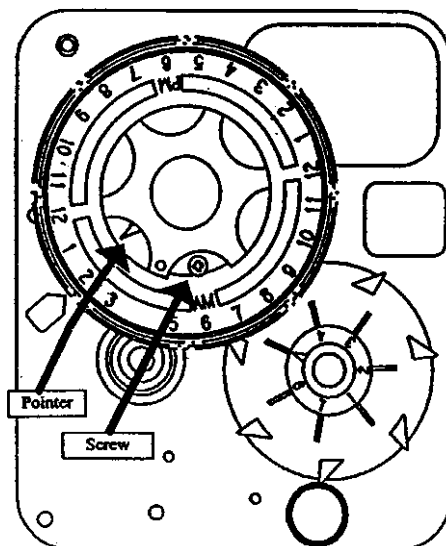
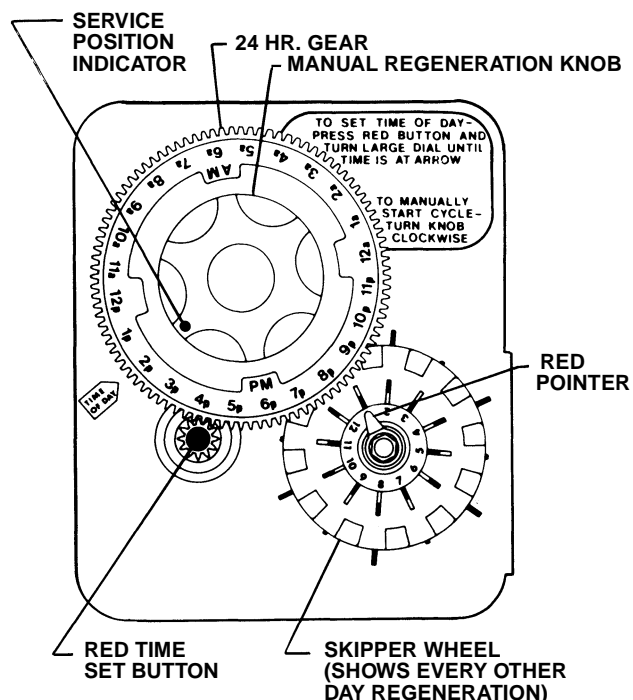

3200 ADJUSTABLE REGENERATION TIMER

**IMPORTANT**  
**SALT LEVEL MUST ALWAYS BE ABOVE WATER LEVEL IN BRINE TANK.**

# MODEL 3200 & 3210 TIMER SERIES

## Regeneration Cycle Program Setting Procedure

### (Brine Tank Refill Separate From Rapid Rinse)

#### How To Set The Regeneration Cycle Program:

The regeneration cycle program on your water conditioner has been factory preset, however, portions of the cycle or program may be lengthened or shortened in time to suit local conditions.

#### 3200 & 3210 Series Timers (Figure to Right)

To expose cycle program wheel, first pull cable out of meter dome of 3210 timers, grasp timer in upper left-hand corner and pull, releasing snap retainer and swinging timer to the right.

To change the regeneration cycle program, the program wheel must be removed. Grasp program wheel and squeeze protruding lugs toward center, lift program wheel off timer. (Switch arms may require movement to facilitate removal.)

Return timer to closed position engaging snap retainer in back plate. Make certain all electrical wires locate above snap retainer post. Reconnect meter cable.

#### Timer Setting Procedure for 3200 and 3210 Timer

##### How To Change The Length Of The Backwash Time:

The program wheel as shown in the drawing is in the service position. As you look at the numbered side of the program wheel, the group of pins starting at zero determines the length of time your unit will backwash.

FOR EXAMPLE: If there are six pins in this section, the time of backwash will be 12 min. (2 min. per pin). To change the length of backwash time, add or remove pins as required. The number of pins times two equals the backwash time in minutes.

##### How To Change The Length Of Brine And Rinse Time:

The group of holes between the last pin in the backwash section and the second group of pins determines the length of time that your unit will brine and rinse (2 min. per hole.)

To change the length of brine and rinse time, move the rapid rinse group of pins to give more or fewer holes in the brine and rinse section. Number of holes times two equals brine and rinse time in minutes.

##### How To Change The Length Of Rapid Rinse:

The second group of pins on the program wheel determines the length of time that your water conditioner will rapid rinse. (2 min. per pin.)

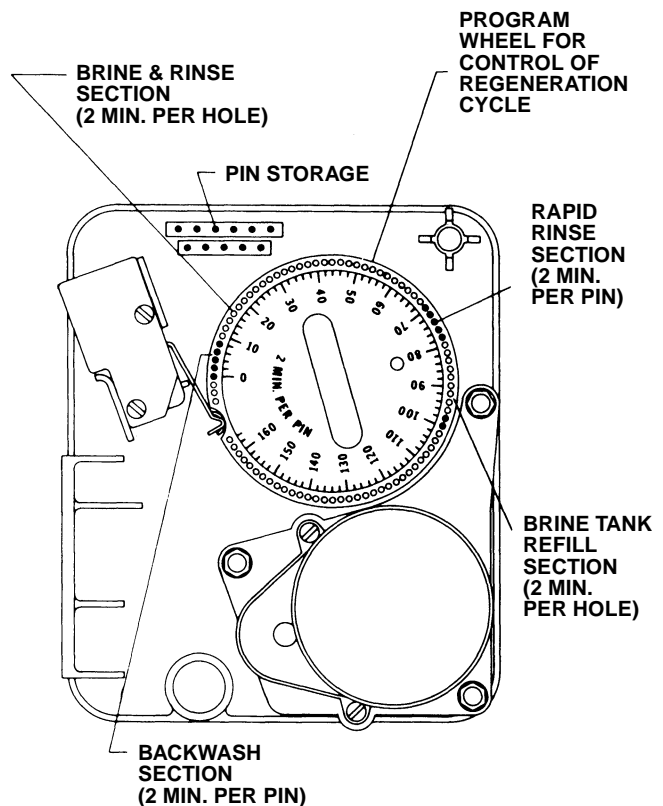

To change the length of rapid rinse time, add or remove pins at the higher numbered end of this section as required. The number of pins times two equals the rapid rinse time in minutes.

##### How To Change The Length Of Brine Tank Refill Time:

The second group of holes in the program wheel determines the length of time that your water conditioner will refill the brine tank. (2 min. per hole.)

To change the length of refill time, move the two pins at the end of the second group of holes as required.

The regeneration cycle is complete when the outer microswitch is tripped by the two pin set at end of the brine tank refill section. The program wheel, however, will continue to rotate until the inner micro-switch drops into the notch on the program wheel.

# MODEL 2850

## 1600 Series Brine System Assembly

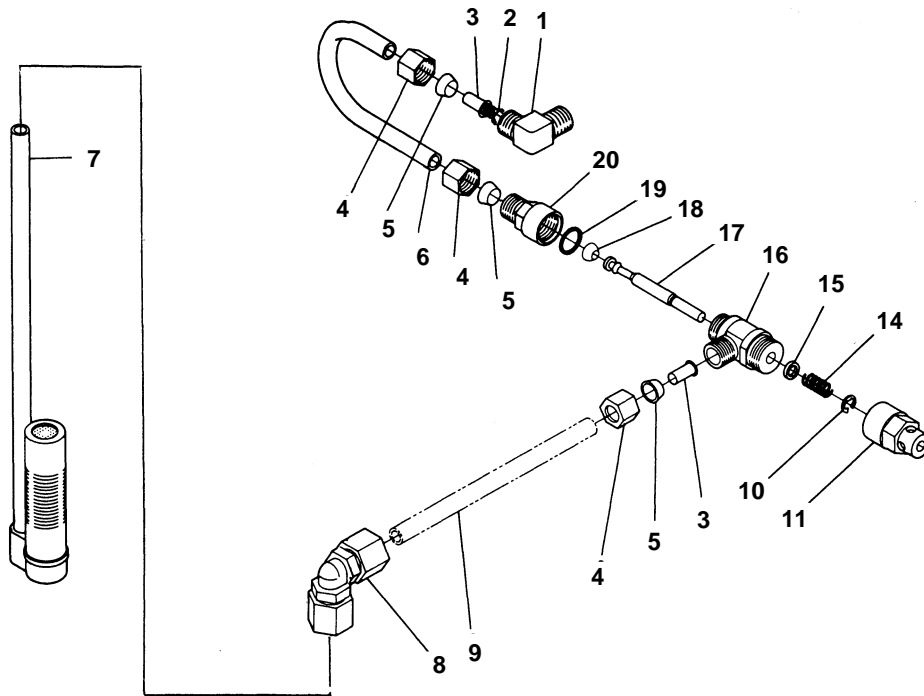

### Parts List

Item No.	Quantity	Part No.	Description
1.....	1.....	10328.....	90° Elbow - 1/4 Pipe Thd. to 3/8 Tube
2.....	1.....	12767.....	Brine Line Screen
3.....	2.....	10332.....	Insert Sleeve (3/8 Tube)
4.....	3.....	10329.....	Fitting Nut (3/8 Tube)
5.....	3.....	10330.....	Delrin Sleeve (3/8 Tube)
6.....	1.....	16508.....	Brine Valve Tube
7.....	1.....	60002.....	#500 Air Check Assembly
	1.....	60003.....	#500 Air Check Assembly, HW
8.....	1.....	12794.....	90° Elbow - 3/8 Tube to 3/8 Tube
9.....	1.....	Not Supplied.....	Brine Line Tube (3/8 Flexible Tube)
10.....	1.....	10250.....	Retaining Ring
11.....	1.....	11749.....	Stem Guide
12.....			Not Assigned
13.....			Not Assigned
14.....	1.....	10249.....	Brine Valve Spring
15.....	1.....	12550.....	Quad Ring
16.....	1.....	12748.....	Brine Valve Body
17.....	1.....	12552.....	Brine Valve Stem
18.....	1.....	12626.....	Brine Valve Seat
19.....	1.....	11982.....	O-Ring
20.....	1.....	60020-25.....	BLFC .25 GPM
		60020-50.....	BLFC .50 GPM
		60020-100.....	BLEC 1.0 GPM

# MODEL 2850

## 1700 Series Brine System Assembly

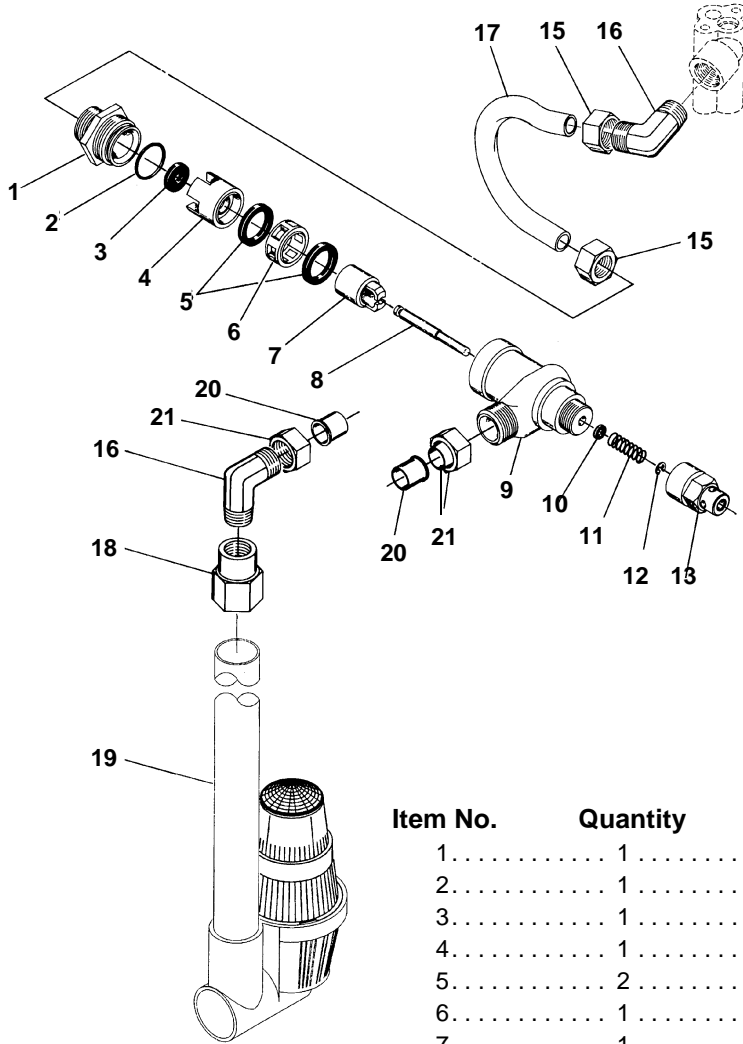

### Parts List

Item No.	Quantity	Part No.	Description
1	1	14792	End Plug
2	1	13201	O-Ring - End Plug
3	1		Washer Flow Control (specify size)
4	1	14785	Flow Control Retainer
5	2	14811	Piston Seals
6	1	14798	Spacer
7	1	14795	Brine Valve Piston
8	1	14797	Brine Valve Stem
9	1	14790	Brine Valve Body
10	1	12550	Quad Ring - Brine Stem
11	1	15310	Spring - Brine Valve
12	1	10250	Retaining Ring
13	1	15517	Stem Guide
15	2	15414	Nut and Sleeve
16	2	15413	Elbow
17	1	16460	Brine Tube
18	1	15434	Reducer Coupling - 1/2 NPT 3/8 NPT
19	1	60009	#900 Air Check Assembly
		60009-01	#900 Air Check Assembly, Hot Water
20	2	16123	Nut
21	2	16124	Sleeve

# MODEL 2850

## 1600 Service Valve Operator

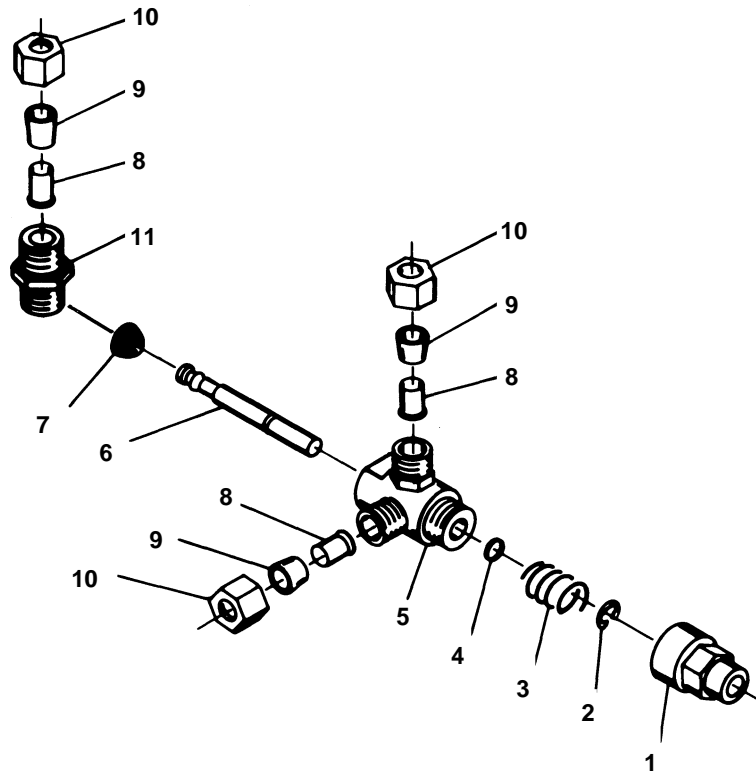

### Parts List

Item No.	Quantity	Part No.	Description
1	1	11749	Brine Valve Nut
2	1	10250	Retaining Nut
3	1	10249	Brine Valve Spring
4	1	12550	Seal O-Ring
5	1	10785	Service Actuator Assembly - .25 gpm
6	1	12552	Brine Valve Stem
7	1	12626	Brine Valve Seat
8	3	10332	Insert Sleeve
9	3	10330	Delrin Sleeve
10	3	10329	Fitting Nut
11	1	10331	Male Connector 1/4 P to 3/8 T

# MODEL 2850 ECONOMINDER®

## 1-1/2" Meter Assembly

(See Opposite Page for Parts List)

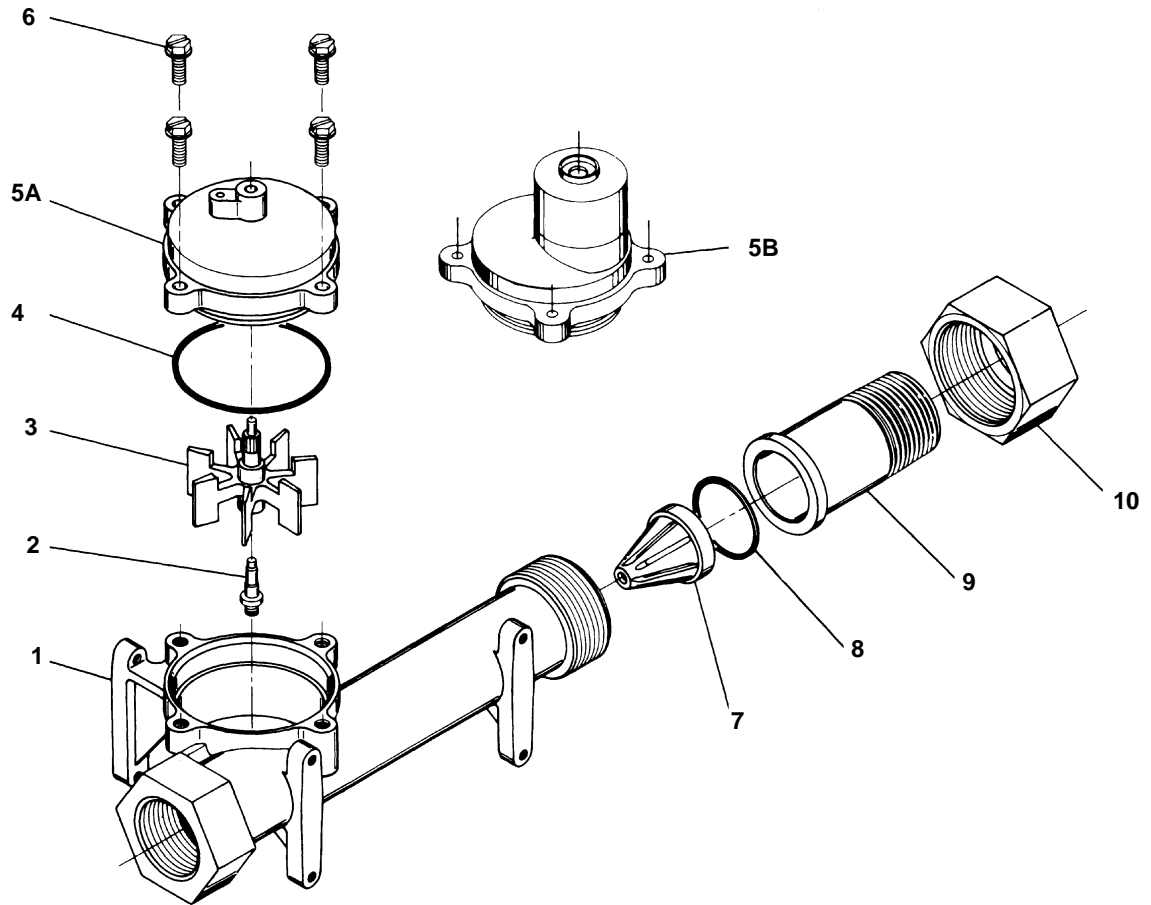

# MODEL 2850 ECONOMINDER®

---

## *1-1/2" Meter Assembly*

---

### *Parts List*

---

<b>Item No.</b>	<b>Quantity</b>	<b>Part No.</b>	<b>Description</b>
1.....	1 .....	17569 .....	Meter Body
2.....	1 .....	13882 .....	Post, Impeller
3.....	1 .....	13509 .....	Impeller
4.....	1 .....	13847 .....	O-Ring — Meter Cover
5A.....	1 .....	15218 .....	Meter Cover Assembly (Std.)
5B.....	1 .....	15237 .....	Meter Cover Assembly (Extended Range)
6.....	4 .....	12112 .....	Screw Meter Cover
7.....	1 .....	17542 .....	Flow Straightener
8.....	1 .....	12733 .....	O-Ring — Quick Connect
9.....	1 .....	17544 .....	Nipple — Quick Connect
10.....	1 .....	17543 .....	Nut — Quick Connect

# MODEL 2850

## 2310 Safety Brine Valve

(See Opposite Page for Parts List)

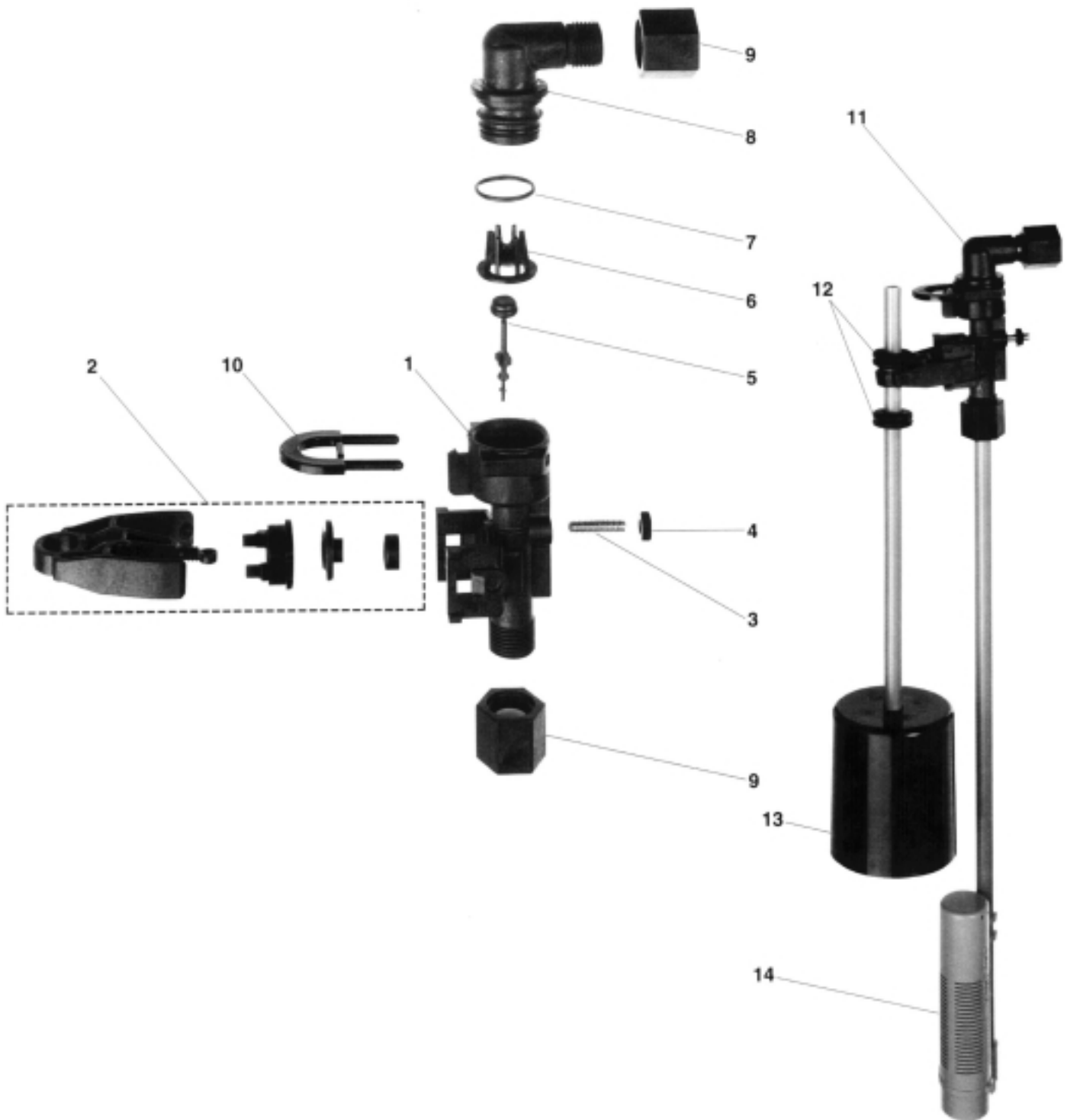



# MODEL 2850

---

## 2310 Safety Brine Valve

---

### Parts List

---

Item No.	Quantity	Part No.	Description
1.....	1 .....	19645 .....	Safety Brine Valve Body
2.....	1 .....	19803 .....	Safety Brine Valve Arm Assembly
3.....	1 .....	19804 .....	Stud, 10-24
4.....	1 .....	19805 .....	Nut, 10-24
5.....	1 .....	19652-01.....	Poppet & Seal
6.....	1 .....	19649 .....	Flow Dispenser
7.....	1 .....	11183 .....	O-Ring, -017
8.....	1 .....	19647 .....	Elbow, Safety Brine Valve
9.....	2 .....	19625 .....	Nut Assembly, 3/8
10.....	1 .....	18312 .....	Retaining Clip
11.....	1 .....	60014 .....	Safety Brine Valve, 2310 (includes items 1-10)
12.....	2 .....	10150 .....	Grommet (included with item 13)
13.....	1 .....	60068 .....	Float Assembly, 2310
14.....	1 .....	60002 .....	500 Air Check Assembly

# SYSTEM #4-SINGLE VALVE REGENERATION

## Immediate and Delayed Valve Wiring

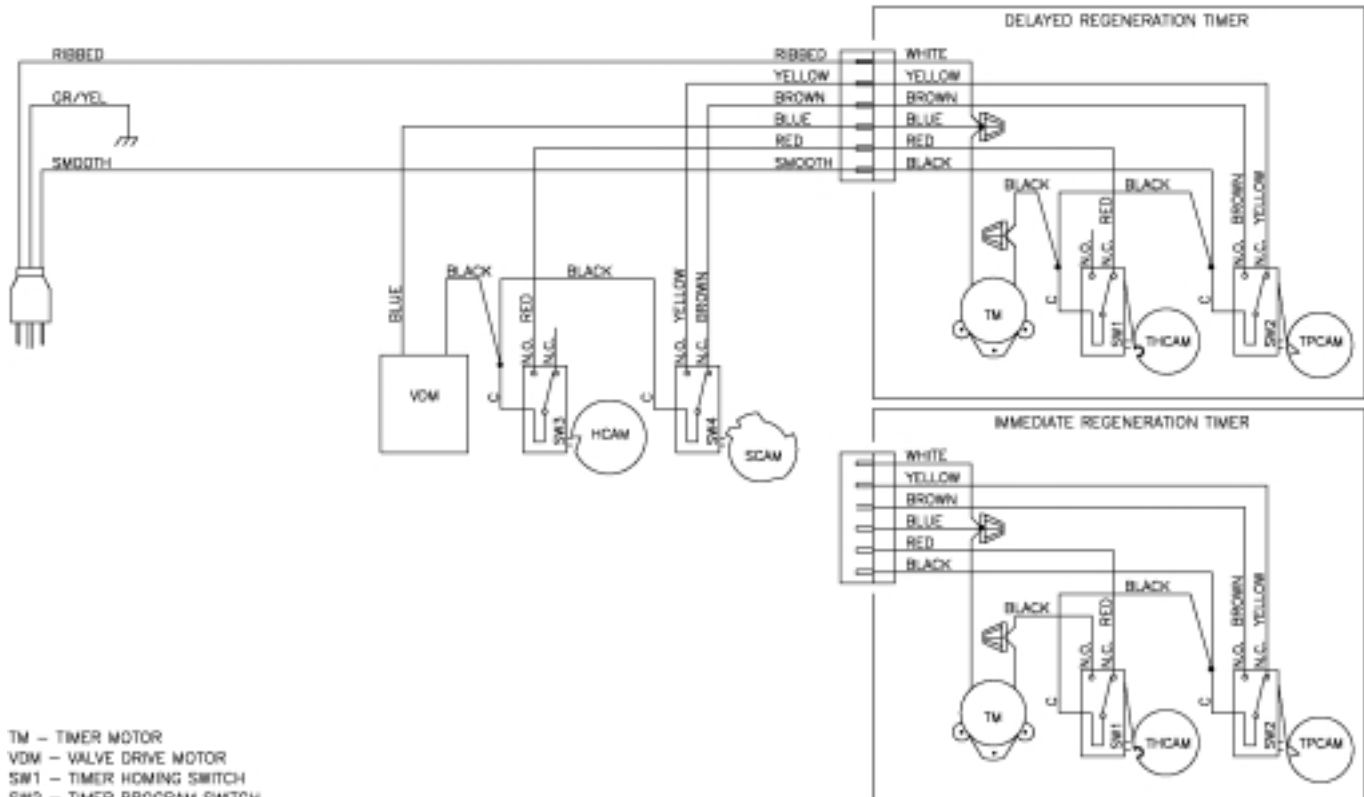

- TM - TIMER MOTOR
- VDM - VALVE DRIVE MOTOR
- SW1 - TIMER HOMING SWITCH
- SW2 - TIMER PROGRAM SWITCH
- SW3 - VALVE HOMING SWITCH
- SW4 - VALVE STEP SWITCH
- THCAM - TIMER HOMING CAM
- TPCAM - TIMER PROGRAM CAM
- HCAM - VALVE HOMING CAM
- SCAM - VALVE STEP CAM

NOTE:  
SINGLE TANK TIMELOCK, METER DELAYED, OR METER IMMEDIATE REGENERATION

# SYSTEM #4-WITH REMOTE STARTER

## Valve Wiring

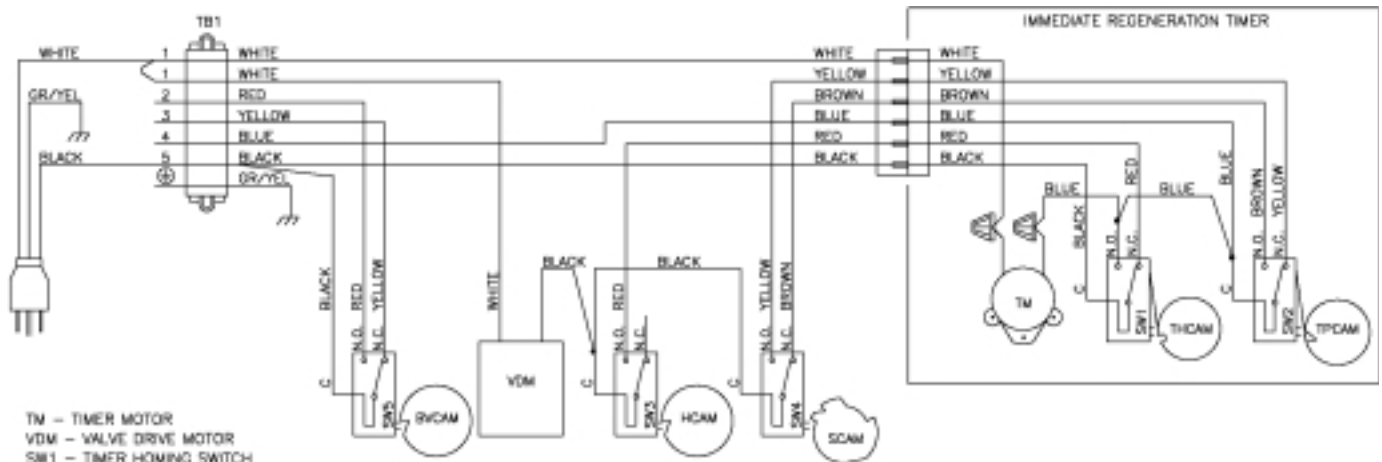

- TM - TIMER MOTOR
- VDM - VALVE DRIVE MOTOR
- SM1 - TIMER HOMING SWITCH
- SM2 - TIMER PROGRAM SWITCH
- SM3 - VALVE HOMING SWITCH
- SM4 - VALVE STEP SWITCH
- SM5 - BRINE CAM SWITCH
- THCAM - TIMER HOMING CAM
- TPCAM - TIMER PROGRAM CAM
- HCAM - VALVE HOMING CAM
- SCAM - VALVE STEP CAM
- BVCAM - BRINE VALVE CAM

NOTE:  
SINGLE TANK REMOTE METER INITIATED DELAYED, OR IMMEDIATE REGENERATION

### REMOTE METER WIRING

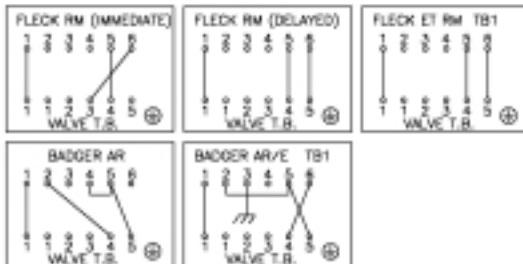

# SYSTEM #5-INTERLOCKED REGENERATION

## Valve Wiring

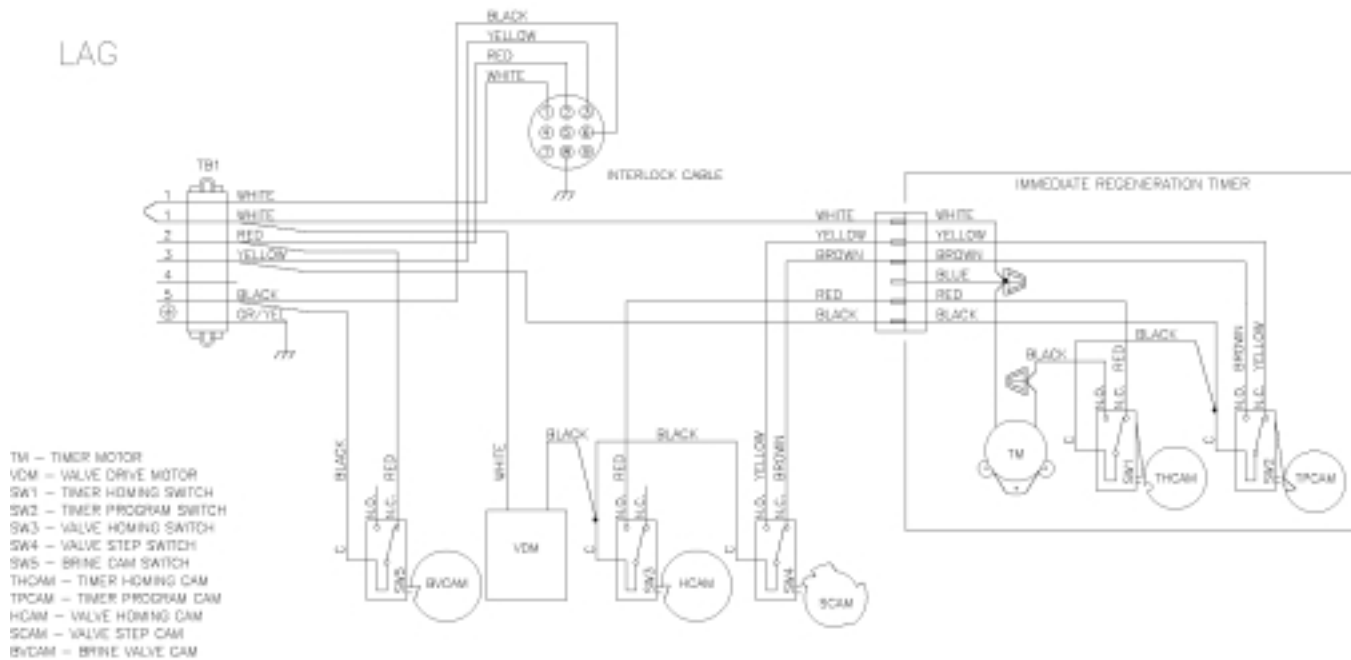
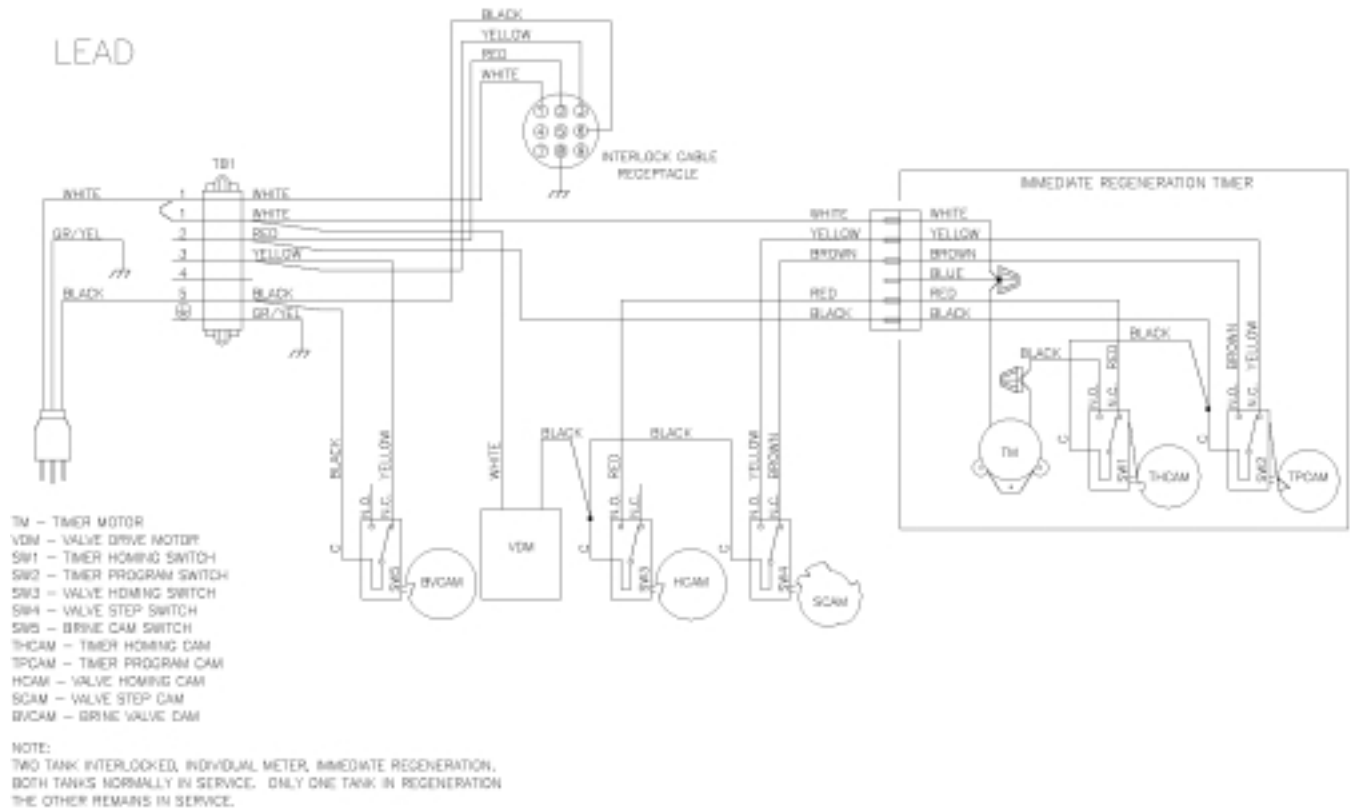

# SYSTEM #6-SERIES REGENERATION

## Valve Wiring

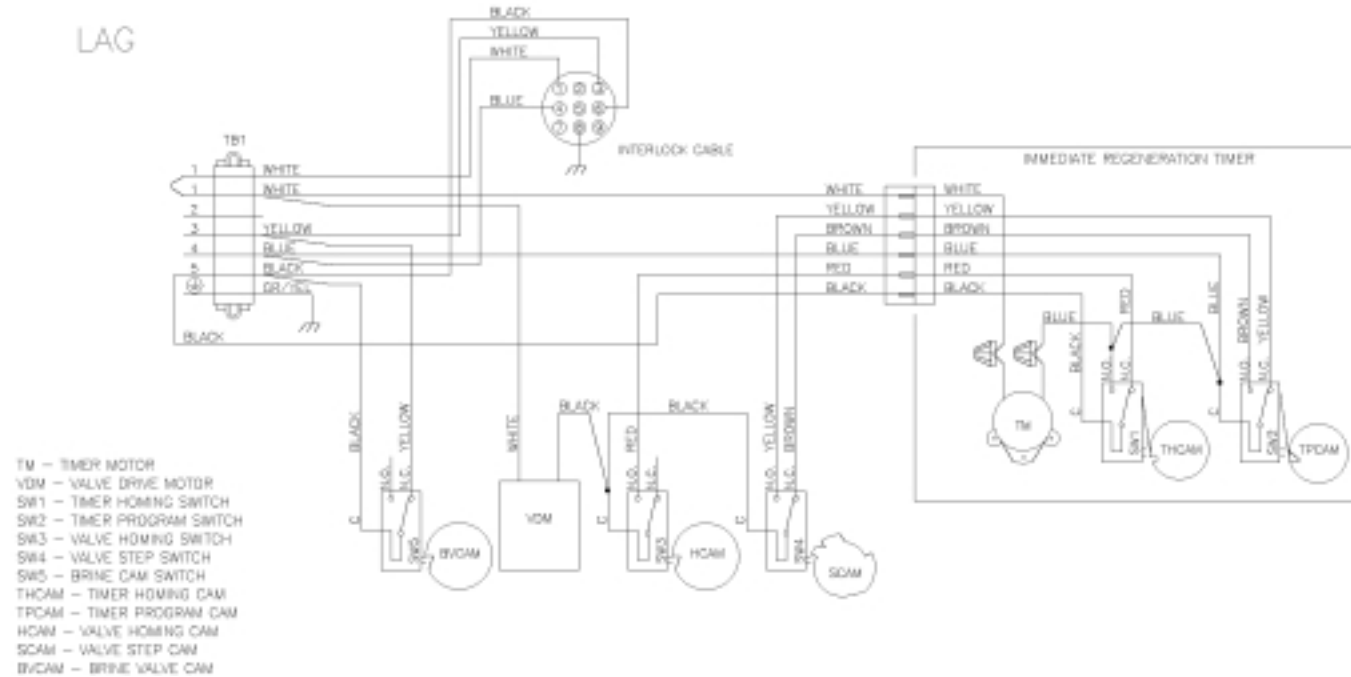
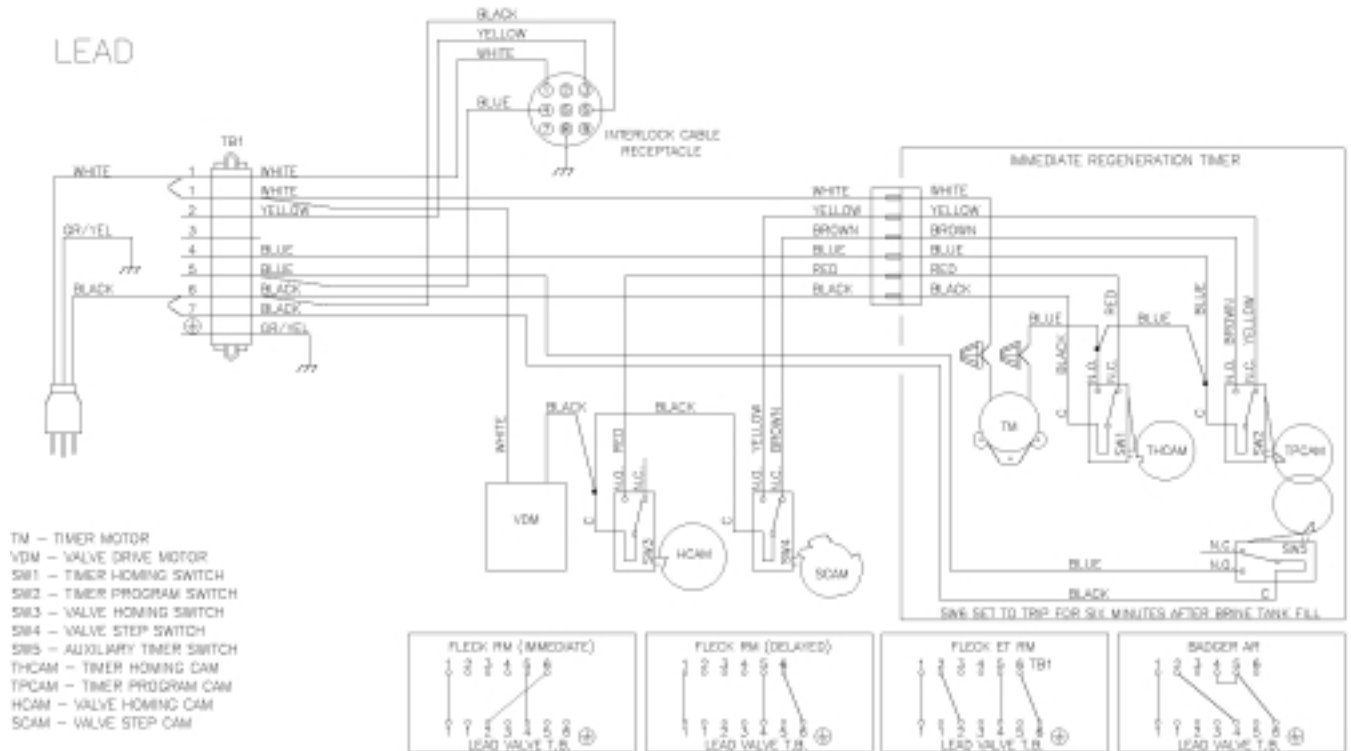

# SYSTEM #7-ALTERNATING REGENERATION

## 230V/3-Way Solenoid Output Valve Wiring

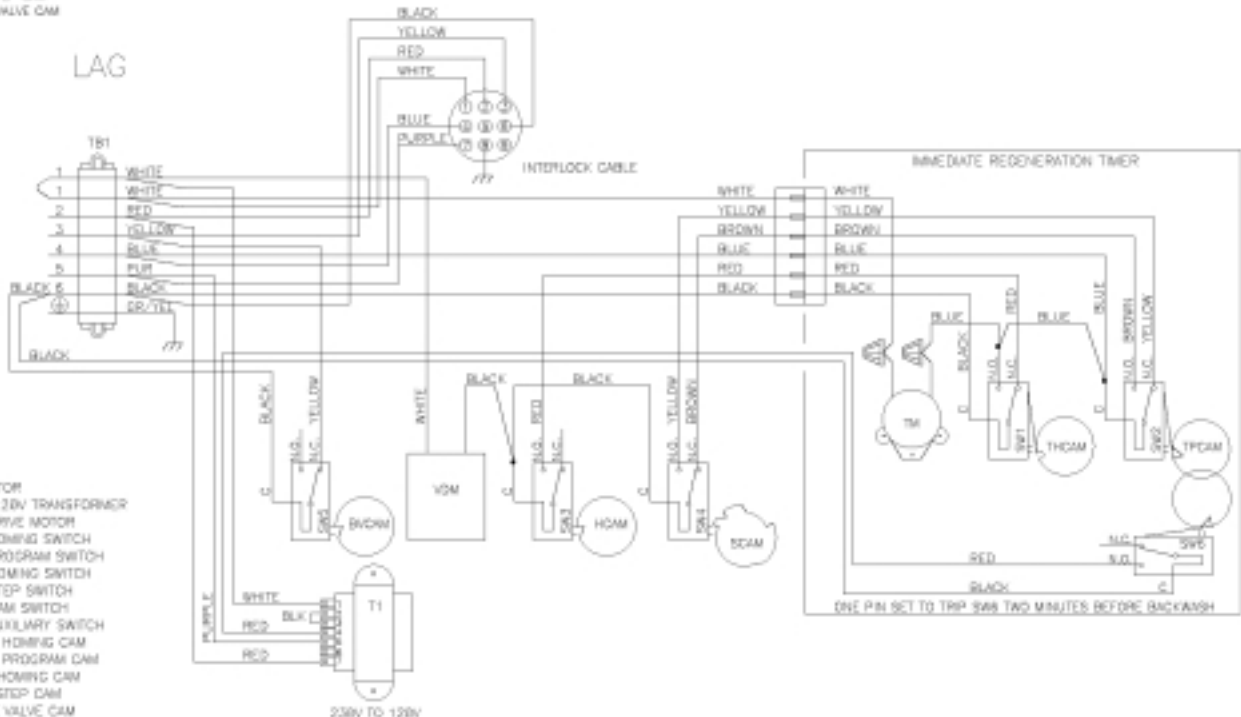
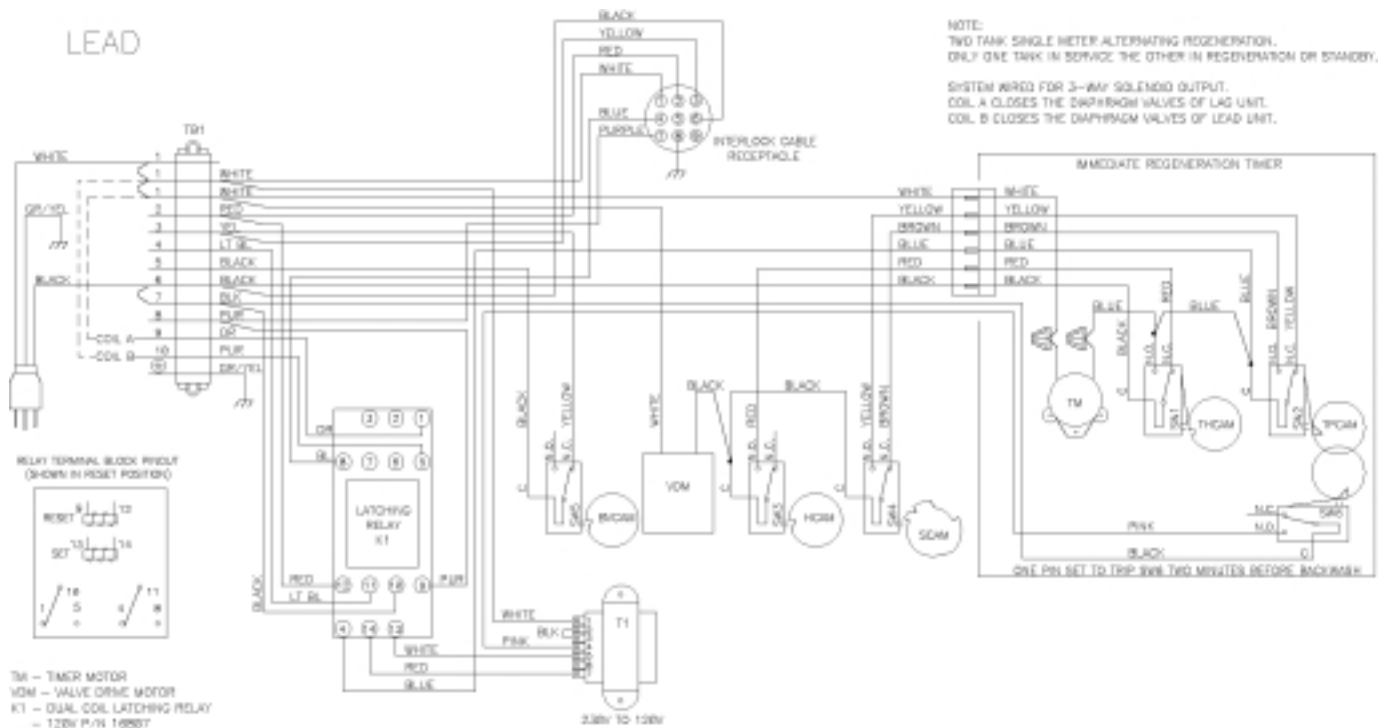

# SYSTEM #7-ALTERNATING REGENERATION

## 24V/120V/3-Way Solenoid Output Valve Wiring

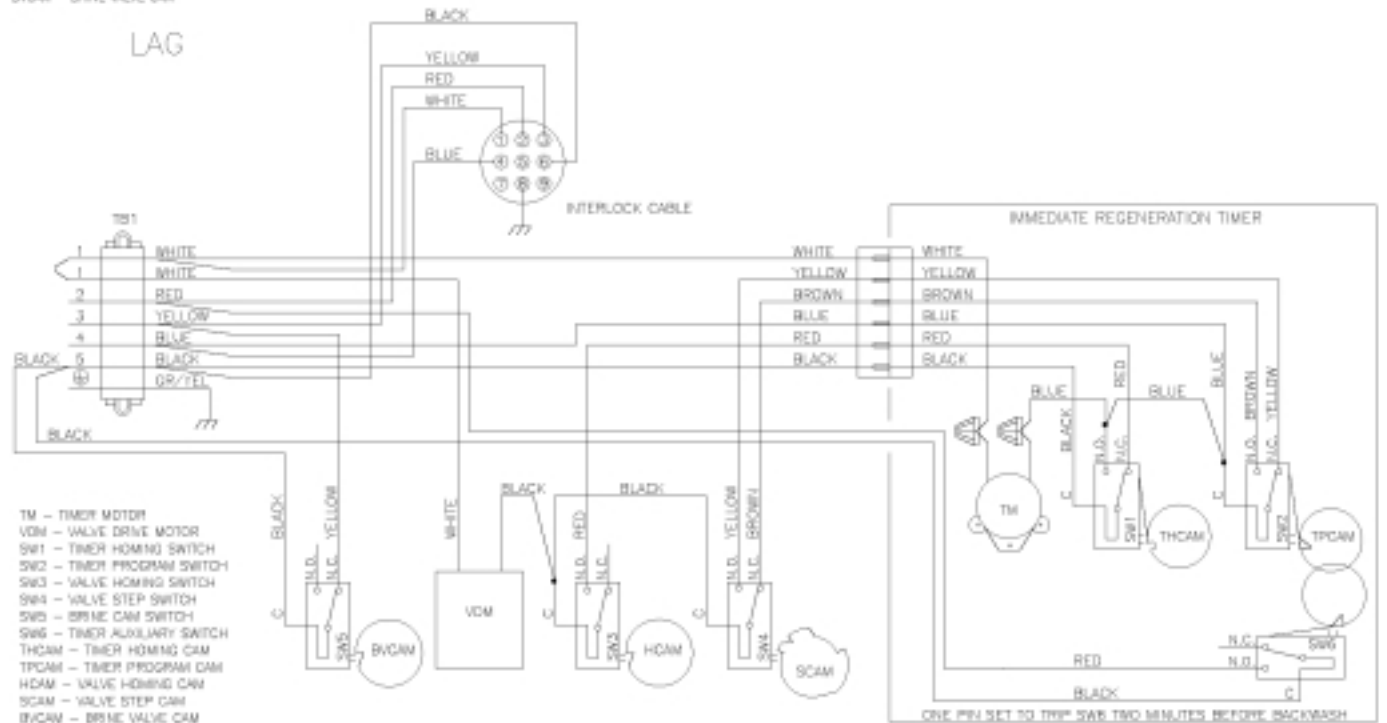
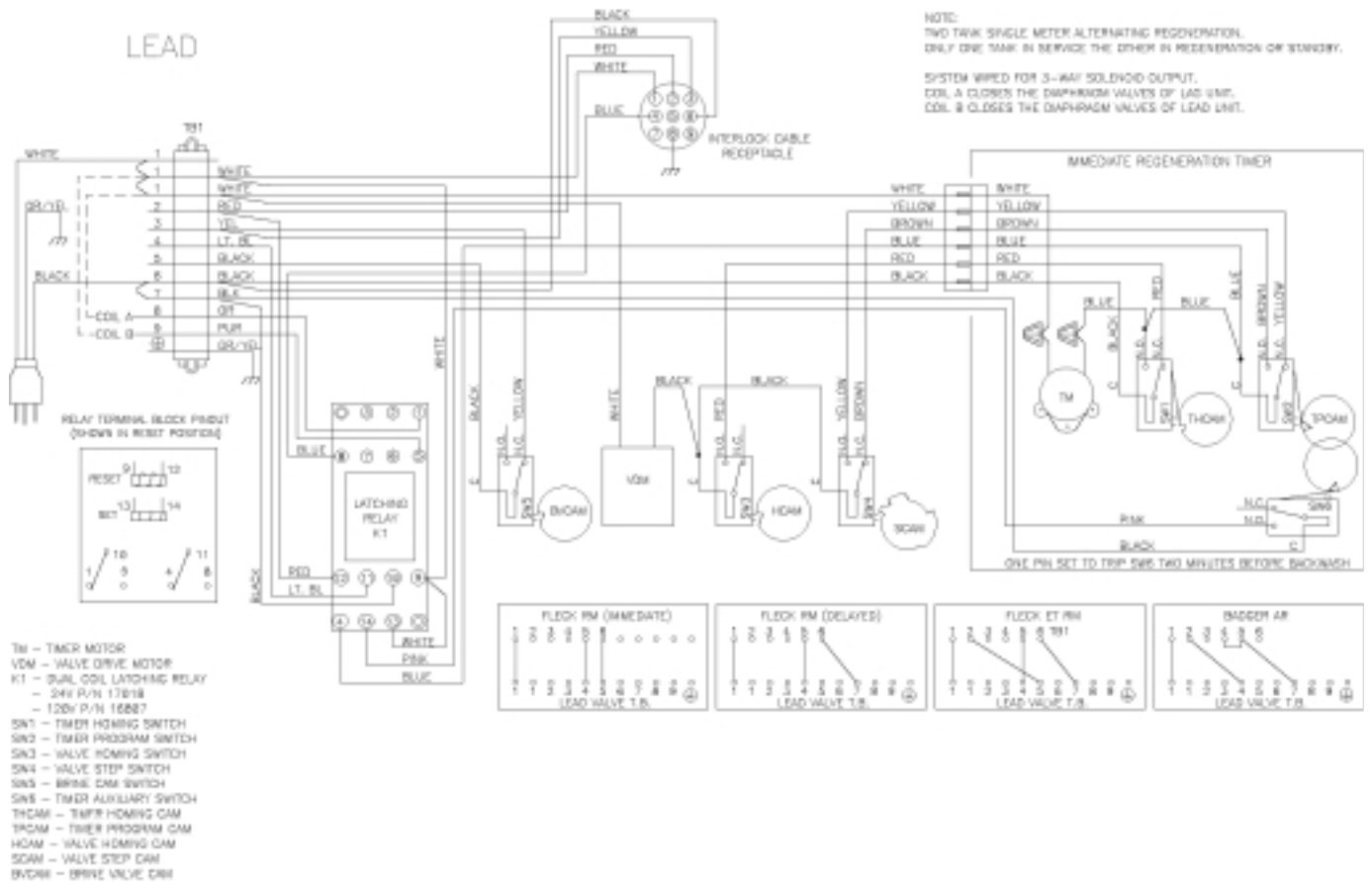

# MODEL 2850

## Flow Data & Injector Draw Rates

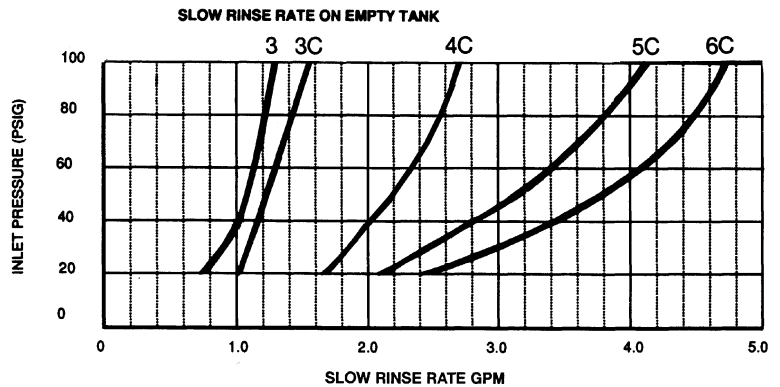
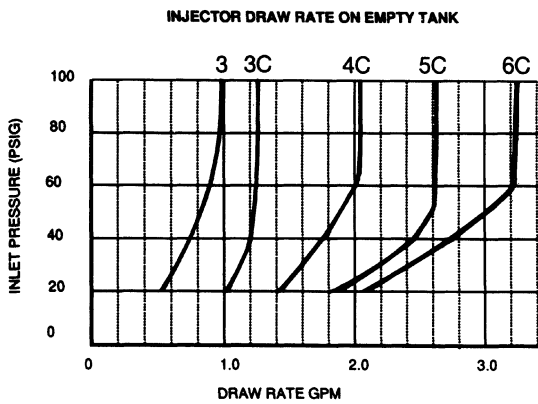
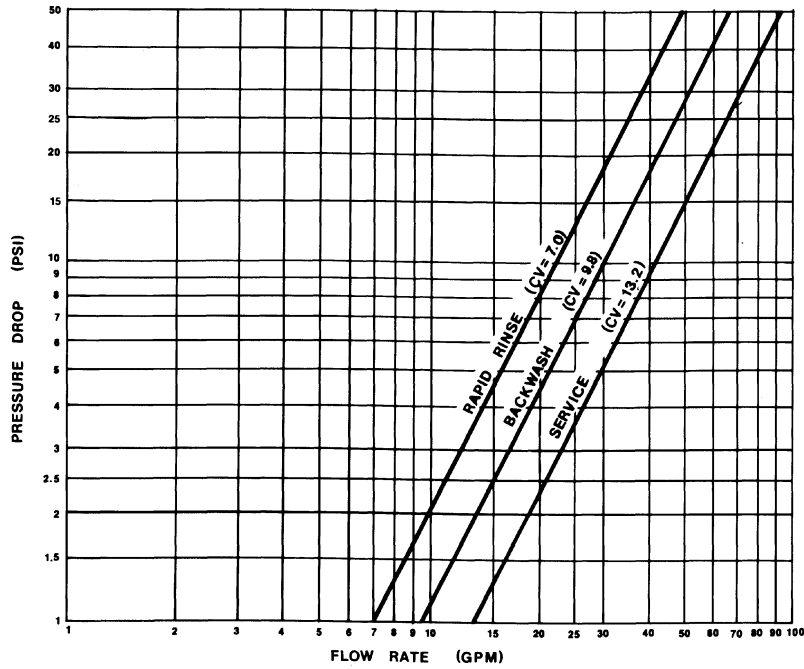



# MODEL 2850

## *\*Typical Timer Settings At Various Salting Levels*

### Salting @ 6# Per Ft<sup>3</sup>

Tank Dia. Volume of Resin	B/W Rate-GPM	B/W Time-Min.	Inj. Size	Brine and Slow Rinse Time-Minutes @ 6# Per Ft <sup>3</sup>			Fast Rinse Time (min.)	Brine Refill Rate GPM	Brine Tank Refill Time-Minutes @ 6# Per Ft <sup>3</sup>
				35 PSI	60 PSI	90 PSI			
14" 3 Ft <sup>3</sup>	5.0	10	3	38	30	26	10	1.0	6 min. 18 lb.
16" 4 Ft <sup>3</sup>	7.0	10	3C	36	30	26	10	1.2	8 min. 24 lb.
21" 7 Ft <sup>3</sup>	10.0	10	4C	40	32	30	10	2.4	8 min. 42 lb.
22" 7 Ft <sup>3</sup>	12.0	10	4C	40	32	30	10	2.0	8 min. 42 lb.
24" 10 Ft <sup>3</sup>	15.0	10	4C	58	48	42	10	2.0	10 min. 60 lb.
30" 15 Ft <sup>3</sup>	25.0	10	5C	64	52	48	10	4.0	8 min. 96 lb.

### Salting @ 10# Per Ft<sup>3</sup>

Tank Dia. Volume of Resin	B/W Rate-GPM	B/W Time-Min.	Inj. Size	Brine and Slow Rinse Time-Minutes @ 10# Per Ft <sup>3</sup>			Fast Rinse Time (min.)	Brine Refill Rate GPM	Brine Tank Refill Time-Minutes @ 10# Per Ft <sup>3</sup>
				35 PSI	60 PSI	90 PSI			
14" 3 Ft <sup>3</sup>	5.0	10	3	58	50	42	10	1.0	10 min. 30 lb.
16" 4 Ft <sup>3</sup>	7.0	10	3C	60	48	44	10	1.2	12 min. 42 lb.
21" 7 Ft <sup>3</sup>	10.0	10	4C	66	54	50	10	2.0	12 min. 72 lb.
22" 7 Ft <sup>3</sup>	12.0	10	4C	66	54	50	10	2.0	12 min. 72 lb.
24" 10 Ft <sup>3</sup>	15.0	10	4C	96	78	70	10	2.0	16 min. 96 lb.
30" 15 Ft <sup>3</sup>	25.0	10	5C	106	86	78	10	4.0	12 min. 144 lb.

### Salting @ 15# Per Ft<sup>3</sup>

Tank Dia. Volume of Resin	B/W Rate-GPM	B/W Time-Min.	Inj. Size	Brine and Slow Rinse Time-Minutes @ 15# Per Ft <sup>3</sup>			Fast Rinse Time (min.)	Brine Refill Rate GPM	Brine Tank Refill Time-Minutes @ 15# Per Ft <sup>3</sup>
				35 PSI	60 PSI	90 PSI			
14" 3 Ft <sup>3</sup>	5.0	10	3	62	52	46	10	1.0	16 min. 48 lb.
16" 4 Ft <sup>3</sup>	7.0	10	3C	86	70	62	10	1.2	18 min. 64 lb.
21" 7 Ft <sup>3</sup>	10.0	10	4C	90	78	70	10	2.0	18 min. 108 lb.
22" 7 Ft <sup>3</sup>	12.0	10	4C	90	78	70	10	2.0	18 min. 108 lb.
24" 10 Ft <sup>3</sup>	15.0	10	5C	96	82	70	10	5.0	10 min. 150 lb.
30" 15 Ft <sup>3</sup>	25.0	10	6C	116	100	88	10	5.0	16 min. 240 lb.

\*Due to varying water conditions, tank sizes and water pressures, the above settings should only be used as a guideline.

# MODEL 2850

## Service Instructions

PROBLEM	CAUSE	CORRECTION
1. Softener fails to regenerate.	A. Electrical service to unit has been interrupted. B. Timer is defective. C. Power failure.	A. Assure permanent electrical service (check fuse, plug, pull chain or switch). B. Replace timer. C. Reset time of day.
2. Hard water.	A. By-pass valve is open. B. No salt in brine tank. C. Injector screen plugged. D. Insufficient water flowing into brine tank. E. Hot water tank hardness. F. Leak at distributor tube. G. Internal valve leak.	A. Close by-pass valve. B. Add salt to brine tank and maintain salt level above water level. C. Clean injector screen. D. Check brine tank fill time and clean brine line flow control if plugged. E. Repeated flushings of the hot water tank is required. F. Make sure distributor tube is not cracked. Check O-ring and tube pilot. G. Replace seals and spacers and/or piston.
3. Unit used too much salt.	A. Improper salt setting. B. Excessive water in brine tank.	A. Check salt usage and salt setting. B. See problem no. 7
4. Loss of water pressure.	A. Iron buildup in line to water conditioner. B. Iron buildup in water conditioner. C. Inlet of control plugged due to foreign material broken loose from pipes by recent work done on plumbing system.	A. Clean line to water conditioner. B. Clean control and add mineral cleaner to mineral bed. Increase frequency of regeneration. C. Remove piston and clean control.
5. Loss of mineral through drain line.	A. Air in water system. B. Improperly sized drain line flow control.	A. Assure that well system has proper air eliminator control. Check for dry well condition. B. Check for proper drain rate.
6. Iron in conditioned water.	A. Fouled mineral bed.	A. Check backwash, brine draw and brine tank fill. Increase frequency of regeneration. Increase backwash time.

# MODEL 2850

## Service Instructions

PROBLEM	CAUSE	CORRECTION
7. Excessive water in brine tank.	<ul style="list-style-type: none"> <li>A. Plugged drain line flow control.</li> <li>B. Plugged injector system.</li> <li>C. Timer not cycling.</li> <li>D. Foreign material in brine valve.</li> <li>E. Foreign material in brine line flow control.</li> </ul>	<ul style="list-style-type: none"> <li>A. Clean flow control.</li> <li>B. Clean injector and screen.</li> <li>C. Replace timer.</li> <li>D. Replace brine valve seat and clean valve.</li> <li>E. Clean brine line flow control.</li> </ul>
8. Softener fails to draw brine.	<ul style="list-style-type: none"> <li>A. Drain line flow control is plugged.</li> <li>B. Injector is plugged.</li> <li>C. Injector screen plugged.</li> <li>D. Line pressure is too low.</li> <li>E. Internal control leak.</li> <li>F. Service adapter did not cycle.</li> </ul>	<ul style="list-style-type: none"> <li>A. Clean drain line flow control.</li> <li>B. Clean injector.</li> <li>C. Clean screen.</li> <li>D. Increase line pressure to 20 P.S.I.</li> <li>E. Change seals, spacers and piston assembly.</li> <li>F. Check drive motor and switches.</li> </ul>
9. Control cycles continuously.	<ul style="list-style-type: none"> <li>A. Missadjusted, broken or shorted switch.</li> </ul>	<ul style="list-style-type: none"> <li>A. Determine if switch or timer is faulty and replace it, or replace complete power head.</li> </ul>
10. Drain flows continuously.	<ul style="list-style-type: none"> <li>A. Valve is not programming correctly.</li> <li>B. Foreign material in control.</li> <li>C. Internal control leak.</li> </ul>	<ul style="list-style-type: none"> <li>A. Check timer program and positioning of control. Replace power head assembly if not positioning properly.</li> <li>B. Remove power head assembly and inspect bore. Remove foreign material and check control in various regeneration positions.</li> <li>C. Replace seals and piston assembly.</li> </ul>

### General Service Hints For Meter Control

**Problem: Softener Delivers Hard Water.**

Cause could be that . . . Reserve Capacity Has Been Exceeded.

**Correction:** Check salt dosage requirements and reset program wheel to provide additional reserve.

Cause could be that . . . Program Wheel Is Not Rotating With Meter Output.

**Correction:** Pull cable out of meter cover and rotate manually. Program wheel must move without binding and clutch must give positive clicks when program wheel strikes regeneration stop. If it does not, replace timer.

Cause could be that . . . Meter Is Not Measuring Flow.

**Correction:** Check meter with meter checker.

# MODEL 2850

## System #4 - Typical Single Tank Installation with Optional Meter

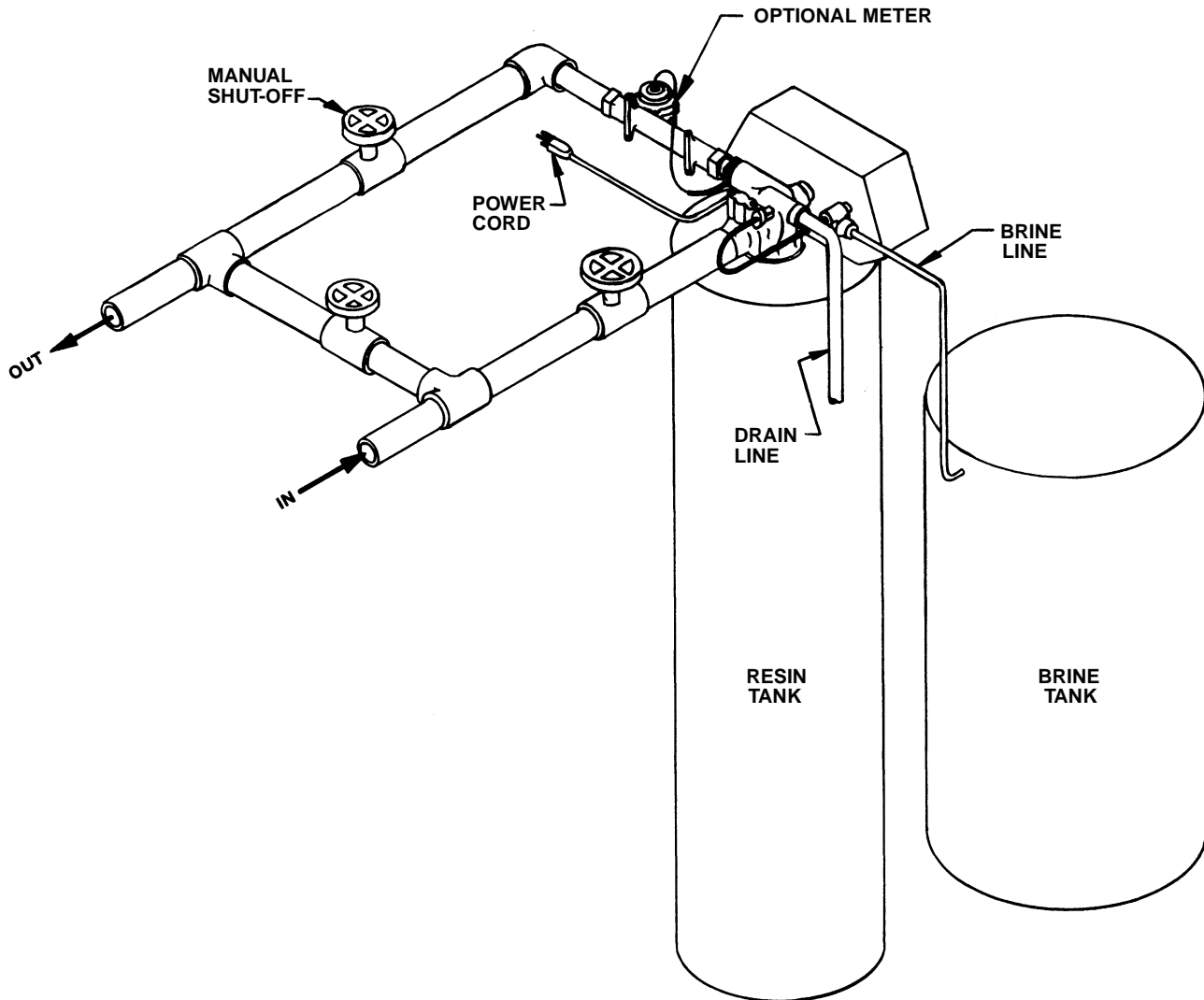

# MODEL 2850

## System #5 Interlock - Typical Twin Tank Installation with Optional Meter Interlock and no Hard Water Bypass

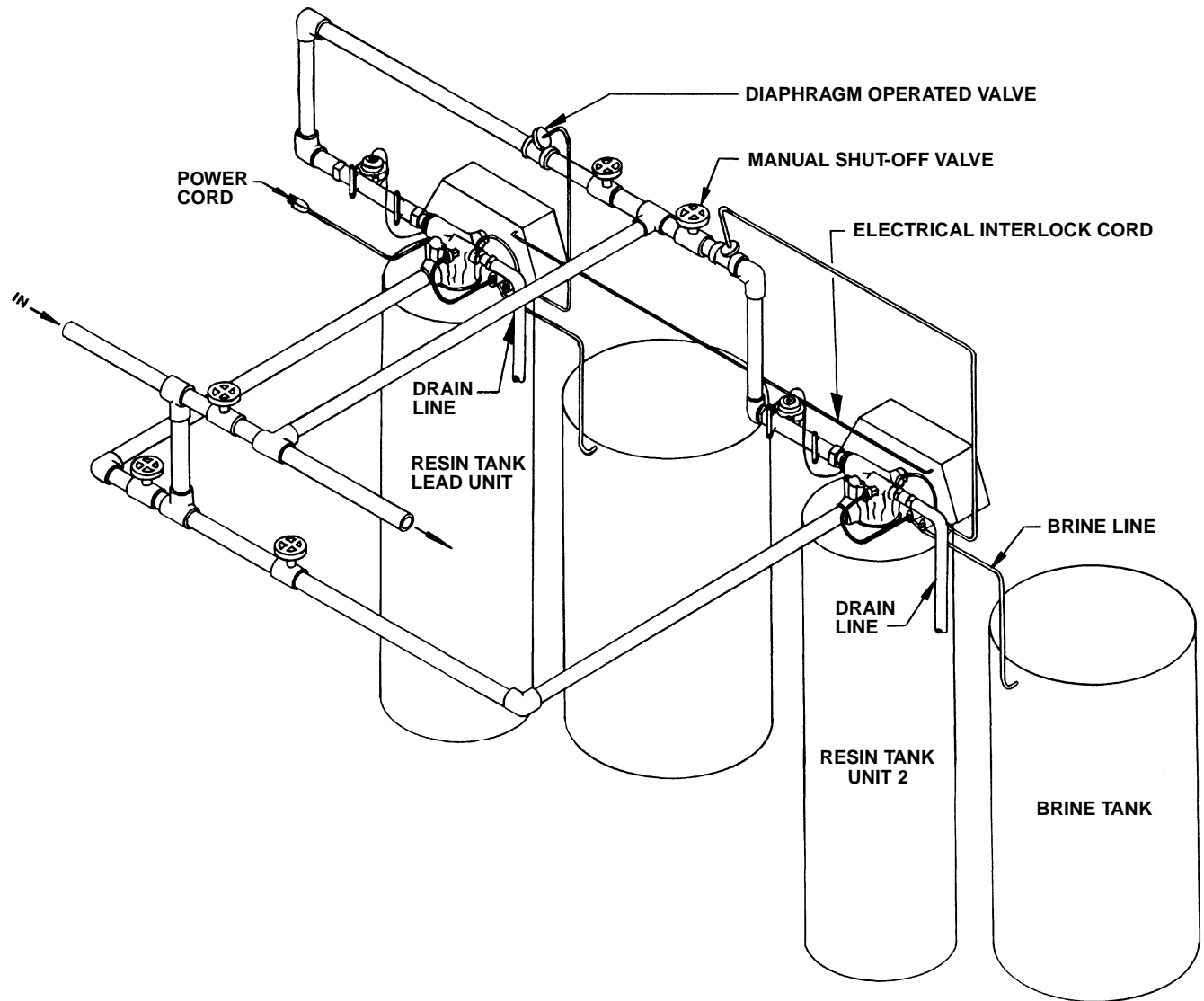

2 tanks, 2 meters; interlock system. Both units in service at the same time. When one of the meters zero out, that unit starts into a regeneration. The other unit remains in service, even if it zeroes out during this time.

# MODEL 2850

## System #6 - Twin Series Regeneration Installation with a Remote Meter

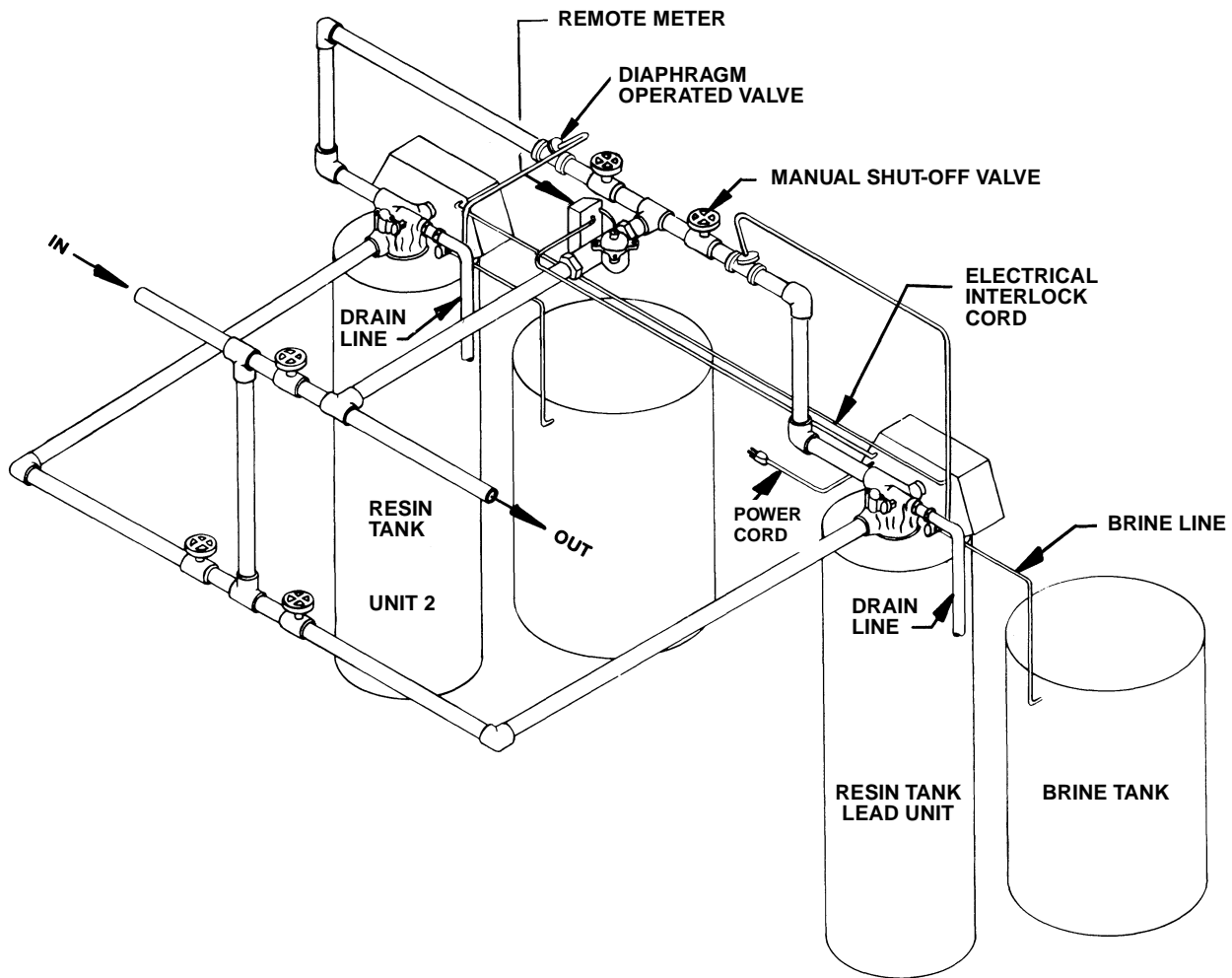

2 tanks, 1 meter; series regeneration system. Both units in service at the same time. When the meter zeroes out; the "lead" unit regenerates. Once the lead unit has returned to the service position, the "lag" unit will regenerate.

# MODEL 2850

## System #7 - Twin Alternator Installation with a Remote Meter

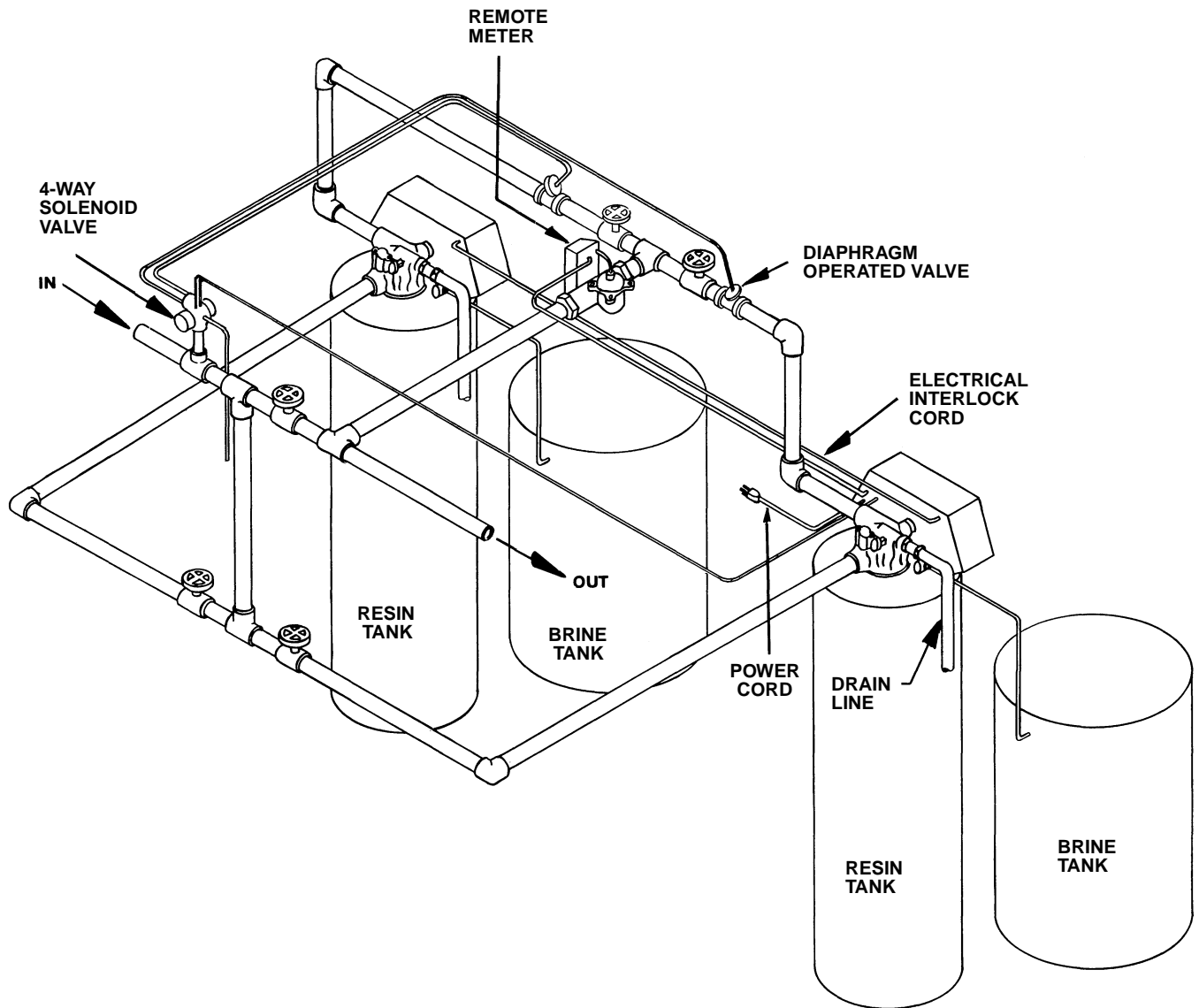

2 tanks, 1 meter; alternator system. One unit in service, the other is on stand-by. When the meter zeroes out, the unit in service goes into a regeneration cycle, the stand-by unit, goes into service.

# MODEL 2850

## Service Assemblies

<b>60029</b>	<b>1600 Brine Valve</b>	For Illustrations, See Page 19
1	10249	Brine Valve Spring
1	10250	Retaining Ring
2	10329	3/8" Brass Nut
2	10330	3/8" Ferrule
2	10332	3/8" Sleeve
1	11749	B/V Stem Guide
1	11982	O-Ring Brine Valve
1	12552	1600 Brine Valve Stem
1	12626	Shut Off Valve Seat
1	12748	Brine Valve Body
1	12550	Quad Ring
<b>60034</b>	<b>1700 Brine Valve</b>	For Illustration, See Page 20
1	10250	Brine Valve Spring
1	12550	Quad Ring
1	13201	Quad Ring
1	14785	Flow Control Retainer
1	14790	Brine Valve Body
1	14792	Brine Valve End Plug
1	14795	Brine Valve Piston
1	14797	Brine Valve Stem
1	14798	Spacer
2	14811	Piston Seal
1	15310	Brine Valve Spring
1	15517	Stem Guide
1	15414	Nut Ferrule 1/2"
1	16123	Nut 1/2"
1	16124	Ferrule 1/2"
<b>60080</b>	<b>1600 Injector Assembly</b>	For Illustration, See Page 6
1	10227	Injector Screen
1	11893	Injector Cap
1	10229	Injector Cover Gasket
1	10328	90° Elbow 1/4" NPT x 3/8 Tube
2	10692	Screw
1	10913	Injector Nozzle
1	10914	Injector Throat
1	11475	Injector Body Gasket
1	17776	Injector Body

<b>60381</b>	<b>1700 Injector Assembly</b>	For Illustration, See Page 6
1	11893	Injector Cap
1	10229	Injector Cover Gasket
1	17777	Injector Body
1	14801	Injector Nozzle
1	14802	Injector Throat
1	14803	Injector Screen
2	14804	Screw
1	14805	Injector Body Gasket

<b>60105</b>	<b>2850 Piston Assembly</b>	For Illustration, See Page 6
1	10909	Connecting Rod Pin
1	16092	Piston
1	16395	End Plug Assembly
1	16436	Piston Rod

<b>60129</b>	<b>2850 Seal and Spacer Kit</b>	For Illustration, See Page 6
6	16101	Seal
5	16638-01	Spacer

<b>60129-10</b>	<b>Seal &amp; Spacer Kit</b>	
6	16101-02	Seal, 2850, Silicone
5	16638-01	Spacer, 9500/2850

<b>60050-21</b>	<b>Drive Motor Assembly, 120V, STF</b>	For Illustration, See Page 8
2	10218	Micro Switch
2	14923	Screw #14 x 1-1/3
2	10302	Insulator
2	10338	Roll Pin 3/22 x 7/8
1	10769	Drive Motor 120V/60Hz
1	10774	Motor Bracket — Drive Side
5	10872	Screw #8 x 5/16
1	11667	Wire Harness
1	11826	Motor Bracket B/V Side
1	12576	Drive Cam — STF
1	12777	Brine Valve Cam
1	13366	Drive Bearing
1	10250	Retaining Ring
1	10621	Connecting Link
1	17904	Plug



# MODEL 2850

## Service Assemblies (Cont'd.)

### 60105-001 . . . Piston Assy., 2850, 560CD

- 1 . . . . . 10909 . . . . . Pin, Link
- 1 . . . . . 16092 . . . . . Piston, 2850
- 1 . . . . . 16395-001 . . . . . End Plug Assy., 2850, 560CD
- 1 . . . . . 16436 . . . . . Rod, Piston, 1-1/2" Valve

### 60105-01 . . . . Piston Assy., 2850, Hot Water

- 1 . . . . . 10909 . . . . . Pin, Link
- 1 . . . . . 16029 . . . . . Piston, 2850
- 1 . . . . . 16395-01 . . . . . End Plug Assy., 2850, Hot Water
- 1 . . . . . 16436 . . . . . Piston, 1-1/2" Valve

### 60050-31 . . . . Drive Motor Assembly, 120V, Tri Stack

- 2 . . . . . 10218 . . . . . Micro Switch
- 2 . . . . . 14923 . . . . . Screw #4 x 1 1/3
- 2 . . . . . 10302 . . . . . Insulator
- 2 . . . . . 10338 . . . . . Roll Pin 3/22 x 7/8
- 1 . . . . . 10769 . . . . . Drive Motor 120V/60 Hz
- 1 . . . . . 10774 . . . . . Motor Bracket — Drive Side
- 5 . . . . . 10872 . . . . . Screw #8 x 5/16
- 1 . . . . . 11667 . . . . . Wire Harness
- 1 . . . . . 11826 . . . . . Motor Bracket B/V Side
- 1 . . . . . 12576 . . . . . Drive Cam — STF
- 1 . . . . . 12472 . . . . . Tri-Stack Cam
- 1 . . . . . 13366 . . . . . Drive Bearing
- 1 . . . . . 10250 . . . . . Retaining Ring
- 1 . . . . . 10621 . . . . . Connecting Link

### Flow Controls

- 60366-35 . . . . . DLFC 1" NPT 3.5 GPM
- 60366-40 . . . . . DLFC 1" NPT 4.0 GPM
- 60366-50 . . . . . DLFC 1" NPT 5.0 GPM
- 60366-60 . . . . . DLFC 1" NPT 6.0 GPM
- 60366-70 . . . . . DLFC 1" NPT 7.0 GPM
- 60701-10 . . . . . DLFC, 1" F x 1" F 10 GPM
- 60701-12 . . . . . DLFC, 1" F x 1" F 12 GPM
- 60701-15 . . . . . DLFC, 1" F x 1" F 15 GPM
- 60701-20 . . . . . DLFC, 1" F x 1" F 20 GPM
- 60701-25 . . . . . DLFC, 1" F x 1" F 25 GPM
- 60702-10 . . . . . DLFC, 1" M x 1" F 10 GPM
- 60702-12 . . . . . DLFC, 1" M x 1" F 12 GPM
- 60702-15 . . . . . DLFC, 1" M x 1" F 15 GPM
- 60702-20 . . . . . DLFC, 1" M x 1" F 20 GPM
- 60702-25 . . . . . DLFC, 1" M x 1" F 25 GPM

### NHWP-P Pistons

- 60114-00 . . . . . Filter Conversion Kit
- 60114-01 . . . . . Piston Assembly Only
- 60114-02 . . . . . 1600 Conversion Kit
- 60114-03 . . . . . 1700 Conversion Kit

### Side Mount Adapter

- 61415 . . . . . NPT/US
- 61415NP . . . . . NPT/US/NICKEL
- 61415-20 . . . . . BSP/METRIC
- 61415-20NP . . . . . BSP/METRIC/NICKEL



### **Statement of Material Safety**

This product has been tested by a recognized third party or certifying laboratory, or conforms to one or more of the following standards or regulations: U.S.A. Food and Drug Administration Title 21 Code of Federal Regulations, American National Standards Institute/NSF International STD 14 Plastics Piping System Components and Related Materials, American National Standards Institute/NSF International 42 Drinking Water Treatment Units - Aesthetic Effects, American National Standards Institute/NSF International STD 44 Residential Cation Exchange Water Softeners, American National Standards Institute/NSF International STD 61 Drinking water system components - Health effects, U.S.A. Environmental Protection Agency Safe Drinking Water Act, DVGW-KWT-Empfehlung, and WRC-BS6920:1990.

**WARNING:** This product contains a chemical known to the State of California to cause **cancer, birth defects or other reproductive harm.**

